

rehabhire & sales

YOUR  
LEADING  
HEALTHCARE  
EQUIPMENT  
PARTNER

**PRIDE**<sup>®</sup>  
MOBILITY

# Full Size Mobility Scooter

## User Manual



1300 000 030 | [rehabhire.com.au](http://rehabhire.com.au)

YOUR  
LEADING  
HEALTHCARE  
EQUIPMENT  
PARTNER

# SCOOTER FEATURES TABLE

EN

Model	Console Style			Frame Style (Assembly/Disassembly)		Anti-tip wheels	Options <sup>+</sup>			Main Circuit Breaker (Type)		
	A	B	C	1-piece frame	2-piece frame	Included	Hi-Low Switch	Handbrake	Suspension Seat Post	Reset Button	Reset Lever	Auto Reset
123			*	*				*		*		
124			*	*				*		*		
133			*	*				*		*		
134			*	*				*		*		
143			*	*				*		*		
144			*	*				*		*		
3120			*	*				*		*		
3130			*	*				*		*		
3140			*	*				*		*		
613	*				*	*	*	*	*	*		
614	*	*		*		*	*	*			*	*
713	*				*	*	*	*	*	*		
7132	*			*		*	*	*			*	
714	*			*		*	*	*			*	*
713ES	*			*		*	*	*			*	*

*\*NOTE: Scooter options vary by country. Please contact your Provider to determine which options are available for your Scooter.*

*NOTE: Please become familiar with your scooter's model number. The number can be found on the product specification sheet in your owner's package. Throughout this owner's manual, Scooter attributes are identified by model number (far left-hand column on Scooter Features Table). Knowing your unit's model number will aid you in determining your particular scooter's unique characteristics.*

## INTENDED USE

The intended use of this Pride Mobility Products device is to provide mobility assistance to persons with mobility impairment who have the capacity to operate a motorized mobility scooter in an indoor/outdoor environment.

## REGARDING DEVICES FOR PRESCRIPTION USE

Our mobility products and their components are available for sale either as retail ("over-the-counter") or with a prescription. When prescribed, the following statement is applicable.



**CAUTION! Federal law restricts this device to sale by or on the order of a physician or other certified personnel licensed by the law of the State (US only) or region in which this personnel practices to use or order the use of this device.**

*NOTE: This owner's manual is compiled from the latest specifications and product information available at the time of publication. We reserve the right to make changes as they become necessary. Any changes to our products may cause slight variations between the illustrations and explanations in this manual and the product you have purchased. The latest/current version of this manual is available on our website.*

*NOTE: This product is compliant with WEEE, RoHS, and REACH directives and requirements.*

*NOTE: This product complies with IPX4 Classification (IEC 60529).*

*NOTE: The scooter and its components are not made with natural rubber latex. Consult with the manufacturer regarding any after-market accessories.*

# CONTENTS

<b>SAFETY GUIDELINES</b>	<b>3</b>
<b>I. SAFETY</b>	<b>4</b>
<b>II. YOUR SCOOTER</b>	<b>7</b>
<b>III. BATTERIES AND CHARGING</b>	<b>25</b>
<b>IV. OPERATION</b>	<b>34</b>
<b>V. COMFORT ADJUSTMENTS</b>	<b>36</b>
<b>VI. DISASSEMBLY AND ASSEMBLY</b>	<b>40</b>
<b>VII. BASIC TROUBLESHOOTING</b>	<b>42</b>
<b>VIII. CARE AND MAINTENANCE</b>	<b>44</b>

## SAFETY GUIDELINES



**WARNING!** An authorized Provider or qualified technician must perform the initial setup of this scooter and must perform all of the procedures in this manual.

The symbols below are used throughout this owner's manual and on the scooter to identify warnings and important information. It is very important for you to read them and understand them completely.



**WARNING!** Indicates a potentially hazardous condition/situation. Failure to follow designated procedures can cause either personal injury, component damage, or malfunction. On the product, this icon is represented as a black symbol on a yellow triangle with a black border.



**MANDATORY!** These actions should be performed as specified. Failure to perform mandatory actions can cause personal injury and/or equipment damage. On the product, this icon is represented as a white symbol on a blue dot with a white border.



**PROHIBITED!** These actions are prohibited. These actions should not be performed at any time or in any circumstances. Performing a prohibited action can cause personal injury and/or equipment damage. On the product, this icon is represented as a black symbol with a red circle and red slash.

# I. SAFETY

## PRODUCT SAFETY SYMBOLS

The symbols below are used on the scooter to identify warnings, mandatory actions, and prohibited actions. It is very important for you to read and understand them completely.

**NOTE:** There are more warnings identified and explained in the Consumer Safety Guide that is included with your scooter. Please become familiar with all the warnings and safety information found in the Consumer Safety Guide and refer to this resource often.



**Read and follow the information in the owner's manual.**



OR



**Manufactured in**



OR



**Indicates UNOCCUPIED scooter securement points.**



**Scooter information label**



OR



OR



**Does not meet ISO 7176-19 standards for occupied transport in a motor vehicle. When travelling in a motor vehicle, do not sit in your scooter.**

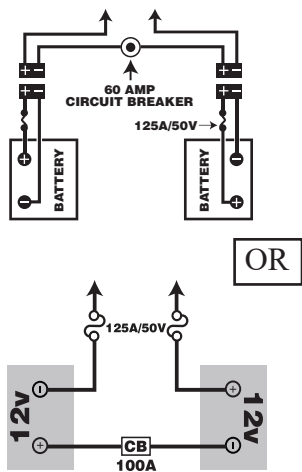

OR

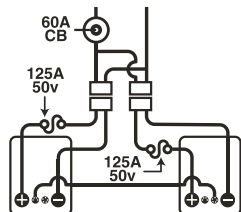

**Battery Set Configuration:**

**+ = Positive (Red) Terminal Post**

**- = Negative (Black) Terminal Post**

**Connect Red wires to Red Positive (+) Terminal Posts. Connect Black wire to Black Negative (-) Terminal Posts.**



**Fully charge batteries before operating.**

**Remove key from an unattended Scooter.**

# I. SAFETY

## GENERAL



**MANDATORY! Do not operate your new scooter for the first time without completely reading and understanding this owner's manual and the Consumer Safety Guide.**

Your scooter is a state-of-the-art life-enhancement device designed to increase mobility. We provide an extensive variety of products to best fit the individual needs of the scooter user. Please be aware that the final selection and purchasing decision regarding the type of scooter to be used is the responsibility of the scooter user, who is capable of making such a decision and his/her healthcare professional (i.e., medical doctor, physical therapist, etc.).

The contents of this manual are based on the expectation that a mobility device expert has properly fitted the scooter to the user and has assisted the prescribing healthcare professional and/or the authorized Provider in the instruction process for the use of the product.

There are certain situations, including some medical conditions, where the scooter user will need to practice operating the scooter in the presence of a trained attendant. A trained attendant can be defined as a family member or care professional specially trained in assisting a scooter user in various daily living activities.

As you begin using your scooter during daily activities, you will probably encounter situations in which you will need some practice. Simply take your time and you will soon be in full and confident control as you maneuver through doorways, on and off elevators, up and down ramps, and over moderate terrain.

Additional general information can be found on the supplemental information sheets and booklets included in your Owner's Package. Please fully read and review the information, and keep it readily available for future reference.

Below are some precautions, tips, and other safety considerations that will help you become accustomed to operating the scooter safely.

### PRE-RIDE SAFETY CHECK

Get to know the feel of your scooter and its capabilities. We recommend that you perform a safety check before each use to make sure your scooter operates smoothly and safely.

#### Perform the following inspections prior to using your scooter:

- Check the condition of the tires. Make sure they are not damaged or excessively worn.
- Check all electrical connections. Make sure they are tight and not corroded.
- Check all harness connections. Make sure they are secured properly.
- Check the brakes to ensure they operate properly.
- Check the battery condition meter to ensure the batteries are fully charged.
- Ensure the manual freewheel lever is in drive mode before sitting on the scooter.
- Prior to riding your scooter, especially after storage, squeeze the handbrake lever fully five to seven (5-7) times to confirm proper function of the handbrake.

If you discover a problem, contact your authorized Provider for assistance. Please refer to the Contact Information insert in your Owner's Package.

# I. SAFETY

## BRAKING INFORMATION

Your scooter is equipped with these powerful brake systems:

- Regenerative: Uses electricity to rapidly slow the vehicle when the throttle control lever returns to the center/stop position.
- Disc Park Brake: Activates mechanically after regenerative braking slows the vehicle to near stop or when power is removed from the system for any reason.
- (Optional) Handbrake: This lever provides you with supplemental stopping power. See II. “Your Scooter.”

## HANDBRAKE LEVER (IF EQUIPPED)

The handbrake lever contains hydraulic fluid. When the lever is depressed, the fluid is pushed through the brake line to engage the brake pads against the brake discs. The handbrake lever is a completely sealed unit, meaning that the hydraulic fluid should not leak; however, there are certain safety measures that should be taken if the handbrake lever becomes cracked or damaged.

- Do not touch spilled material unless wearing protective equipment, such as safety goggles and gloves.
- For small spills, cover the material with dry earth, sand or other non-combustible absorbent material. Once absorbed, enclose the material in a plastic bag and contact your local waste disposal agency for proper disposal measures. Do not expose the material to waterways or sewers.
- If the eyes are exposed, check for and remove contact lenses. Flush eyes with cool, clean, low-pressure water while occasionally lifting and lowering the eyelids. Seek medical attention if excessive tearing, redness or pain persists.
- If the skin is exposed, remove all contaminated clothing. Wipe off excess material and wash exposed skin with soap and water. Seek medical attention if skin appears damaged or if irritation persists. Thoroughly clean contaminated clothing before reuse. Discard contaminated leather goods.
- If ingested, do not induce vomiting or give anything to drink unless directed to by a physician. Never give anything by mouth to a person who is not fully conscious. Seek medical attention immediately.
- If inhaled, move the affected individual to fresh air. If the affected individual is not breathing, immediately begin rescue breathing. If breathing is difficult, 100% humidified oxygen should be administered by a qualified individual. Seek medical attention immediately and keep the affected individual warm and at rest.
- If ignited, use dry chemical, foam, carbon dioxide or water fog to extinguish.

**WARNING! Do not modify the handbrake lever or attempt to replace the hydraulic fluid. If damage occurs, follow the safety information in this section and contact your authorized provider for handbrake replacement. The hydraulic handbrake should only be serviced or replaced by your authorized provider.**



**WARNING! The handbrake contains hydraulic fluid that can cause mild skin, eye and nasal/bronchial irritation. Do not attempt to adjust or service the handbrake without proper protective equipment such as safety goggles and gloves, and wash hands after handling.**

# II. YOUR SCOOTER

## TILLER CONSOLE

The tiller console houses all of the controls needed to drive your scooter, including the speed adjustment dial, key switch, battery condition meter, status LED, horn buttons, turn signal buttons, handbrake lever, tiller adjustment lever, and the throttle control lever. Please note that some of the features listed in this section are optional items and may not appear on your scooter. See figure 1.

**NOTE:** If your scooter is equipped with an LCD Control Panel, please advance to the page in this section that begins **TILLER CONSOLE: LCD CONTROL PANEL**.

**NOTE:** If your scooter is equipped with an optional handbrake, please advance to the page in this section that begins **TILLER CONSOLE: HANDBRAKE LEVER**.



**PROHIBITED!** Do not expose the tiller console to moisture. In the event that the tiller console does become exposed to moisture, do not attempt to operate your scooter until the tiller console has dried thoroughly.

### IDENTIFICATION KEY

- |                              |                              |
|------------------------------|------------------------------|
| 1. HORN BUTTON               | 8. SPEED ADJUSTMENT DIAL     |
| 2. *LEFT TURN SIGNAL BUTTON  | 9. BATTERY CONDITION METER   |
| 3. *HAZARD LIGHTS SWITCH     | 10. KEY SWITCH               |
| 4. LIGHT SWITCH              | 11. MIRROR AND MIRROR PLUGS  |
| 5. *RIGHT TURN SIGNAL BUTTON | 12. *TILLER ADJUSTMENT LEVER |
| 6. *HI-LOW SWITCH            | 13. *HANDBRAKE LEVER         |
| 7. THROTTLE CONTROL LEVER    | 14. *BRAKE LOCK              |

\*OPTIONAL COMPONENTS AVAILABLE ON SOME MODELS

\*\*LOCATION OF HI-LOW SWITCH MAY VARY DEPENDING ON MODEL \*\*

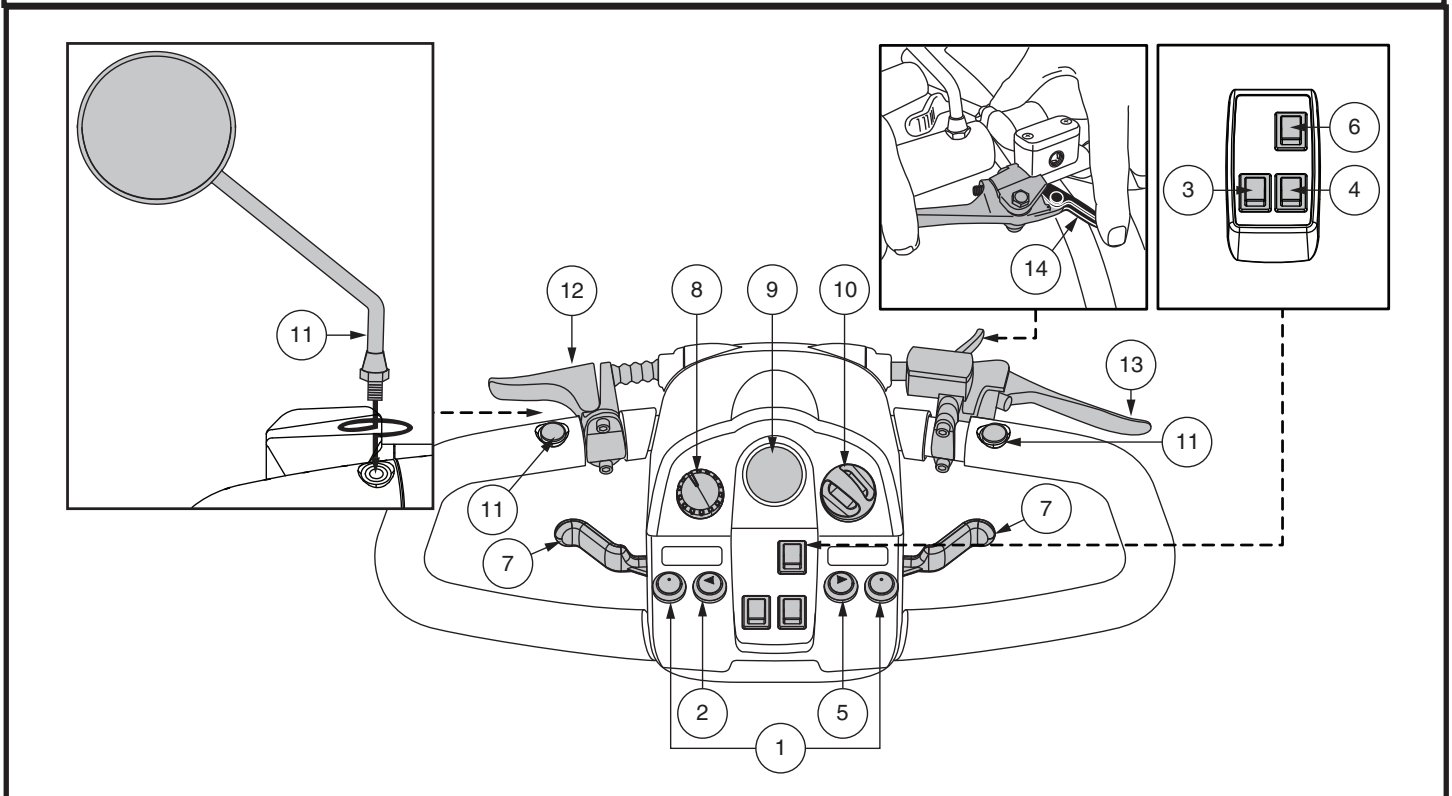

Figure 1. Tiller Console Components - Style A

## II. YOUR SCOOTER

### Horn Buttons

These buttons activate a warning horn. Your scooter must be powered up for the horn to be operational. Do not hesitate to use the warning horn when doing so may prevent accident or injury.

### Turn Signal Buttons

Use these buttons to turn on the left and right turn signal (amber) lights.

- Push the left button to activate the left turn signal light. The turn signal LED located in the battery condition meter will flash.
- Push the right button to activate the right turn signal light. The turn signal LED located in the battery condition meter will flash.
- The turn signals are timed to shut off automatically.

### Lights Switch

This switch controls your scooter's lighting system.

- Toggle the switch forward to turn on the lighting system.
- Toggle the switch rearward to turn off the lighting system.



**WARNING! Scooter users are required to use their lights when visibility is restricted—day or night.**

### Hazard Lights Switch

This switch activates the 4-way flashers on your scooter.

- Toggle the hazard lights switch forward to turn on the flashers.
- Toggle the hazard lights switch rearward to turn off the flashers.

### Hi-Low Switch

This switch toggles the scooter's speed between Hi and Low. Toggle the switch forward (Hi) to achieve the maximum preprogrammed speed for the scooter. Toggle the switch rearward (Low) to achieve half the maximum preprogrammed speed of the scooter.

### Throttle Control Lever

This lever allows you to control the forward speed and the reverse speed of your scooter up to the maximum speed you preset with the speed adjustment dial.

***NOTE:** The throttle control lever operation instructions outlined below apply to scooters in a standard configuration. If the programming of your scooter was modified in any way by an authorized provider, contact that provider for correct throttle control level operation instructions.*

#### To Move Forward, use either of the following:

- Use your left thumb to push the left side of the throttle control lever.
- Use your right hand fingers to pull back on the right side of the throttle control lever.

#### To Move Rearward, use either of the following:

- Use your right thumb to push the right side of the throttle control lever.
- Use your left hand fingers to pull back on the left side of the throttle control lever.

Release the throttle control lever and allow your scooter to come to a complete stop before engaging the other side of the lever. When the throttle control lever is completely released, it automatically returns to the center “stop” position and engages your scooter's brakes.

### Speed Adjustment Dial

This dial allows you to preselect and limit your scooter's top speed.

- The image of the **tortoise** represents the slowest speed setting
- The image of the **hare** represents the fastest speed setting.

## II. YOUR SCOOTER

### Battery Condition Meter

When the key is fully inserted and turned clockwise to power up your scooter, this meter indicates the approximate battery voltage strength. For further information on battery charging, see III. “Batteries and Charging.”

### Status LED

The status LED alerts you to electrical problems that may occur with the scooter. The LED remains constantly lit while your scooter is on. If your scooter develops an electrical problem, the status LED will flash a code. See VII. “Basic Troubleshooting” for flash codes.

### Key Switch

- Insert the key into the key switch and turn it clockwise to power up (turn on) your scooter.
- Turn the key counterclockwise to power down (turn off) your scooter.



**WARNING! When faced with an emergency situation, switch off the key to power off the scooter. Use caution. Be advised that turning off power to the scooter may cause the scooter to stop abruptly. To release the emergency stop and restore driving capability to the scooter, release the throttle control lever and then switch on the key to the scooter.**

**WARNING! If the key is turned to the “off” position while your scooter is in motion, the electronic brakes will engage and your scooter will come to an abrupt stop.**

### Mirror Positioning and Adjustment

For information on positioning and adjusting your mirror, see V. “Comfort Adjustments.”

### Tiller Angle Adjustment

For information on positioning and adjusting your tiller, see V. “Comfort Adjustments.”

### Handbrake Lever

This lever provides you with supplemental stopping power. When in motion, release the throttle control lever and gently squeeze the handbrake lever to come to a stop. Handbrake effectiveness can be modified by tightening or loosening the setscrew located on the handbrake lever.



**WARNING! The handbrake is intended for use as a supplemental braking.**

### Off-board Charger Port

The off-board charger power cord plugs into this port during battery charging. The off-board charger port is located on the tiller. See figure 2.

### Electrical System Fuses

Your scooter is equipped with a series of electrical system fuses, which help protect the off-board charging system, key switch and lighting system from receiving an overload of electrical current. These fuses are the same type used in automobiles and are located in a compartment on the tiller. See figure 2. See VIII. “Care and Maintenance” for fuse replacement.

**NOTE: Keep all electrical areas clean and free of moisture and foreign material.**

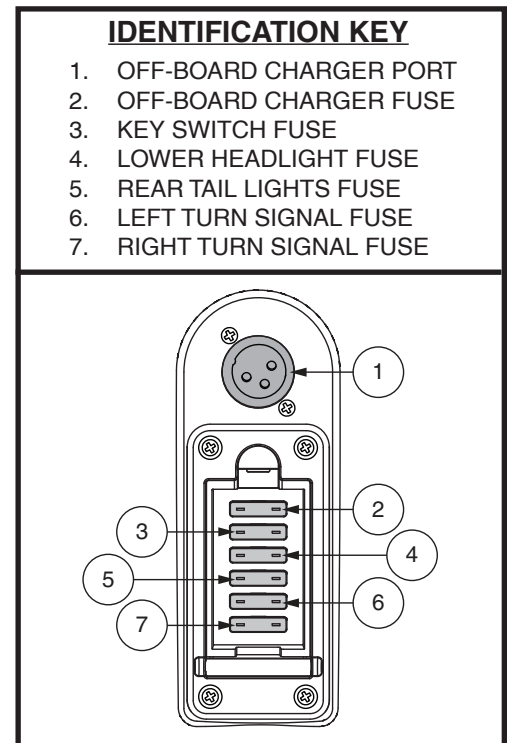

Figure 2. Off-board Charger Port/Tiller Console Fuses

## II. YOUR SCOOTER

### Tiller Console: Handbrake Lever

Your scooter is equipped with a handbrake lever which is located on the tiller handle. See figure 1 and figure 7. This lever provides you with additional stopping power. The handbrake is manual and operates independently of your scooter's regenerative braking system which is engaged during operation of the scooter by releasing the throttle control lever.

#### To operate the handbrake lever:

1. Release the throttle control lever fully.
2. Gently squeeze the handbrake lever to bring your scooter to a complete stop.

**NOTE:** You must release the throttle control lever before squeezing the handbrake lever. Otherwise, your scooter may not come to a complete stop.

**NOTE:** The handbrake lever may require periodic adjustment to maintain proper operation. Adjustment should only be performed by your authorized provider or other qualified technician. Contact your authorized provider for more information.

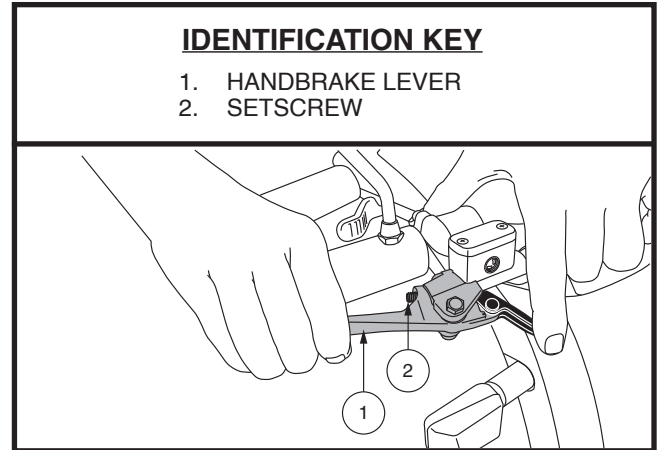

Figure 3. Handbrake Lever

**NOTE:** Handbrake effectiveness, which is how quickly the squeezing of the handbrake lever will bring your scooter to a stop, can be modified by tightening or loosening the setscrew located on the handbrake lever. See figure 3.

**NOTE:** If your handbrake is equipped with a lock function as shown in figure 1 or figure 7, you can activate the brake lock function by squeezing the handbrake lever and rotating or pushing the lock lever to engage the lock. To release the handbrake lock, fully squeeze the handbrake lever. See figure 1 or figure 7.

**NOTE:** If your handbrake contains hydraulic fluid, do not attempt to modify or replace the handbrake lever or the hydraulic fluid.

**NOTE:** Prior to riding your scooter, especially after storage, squeeze the handbrake lever fully five to seven (5-7) times to confirm proper function of the handbrake.

**WARNING!** The hydraulic fluid can cause mild skin, eye, and nasal/bronchial irritation. If damage occurs, contact your authorized provider for handbrake replacement. The hydraulic handbrake should only be serviced or replaced by your authorized provider.



**WARNING!** The handbrake is intended for use as a supplemental braking system to the throttle controlled regenerative braking system, or to help bring the scooter to a stop in the event that the regenerative braking system does not engage. The handbrake is not intended for use as the primary braking system. Misuse or improper use of the handbrake may result in a crash, a fall, personal/property injury, or death.

## II. YOUR SCOOTER

### TILLER CONSOLE: LCD CONTROL PANEL

The tiller console and lower tiller house all of the controls needed to drive your scooter, including the LCD control panel, throttle control levers, key switch, and the throttle control lever switch. See figure 4.



**PROHIBITED!** Do not expose the tiller console to moisture. In the event that the tiller console does become exposed to moisture, do not attempt to operate your scooter until the tiller console has dried thoroughly.

*NOTE: Not all options are available on all styles of consoles with LCD displays.*

### Horn Buttons

These buttons activate a warning horn. Your scooter must be powered up for the horn to be operational. Do not hesitate to use the warning horn when doing so may prevent accident or injury.

### Turn Signal Buttons

- Press the appropriate turn signal button once to activate it. The turn signal will flash on the LCD screen.
- Press the same signal button to turn it off.

*NOTE: The turn signals are timed to shut off after 15 seconds. A warning beep will sound as long as the turn signal is on. See figure 5 for volume control.*

### Lights Button

- Press the lights button once to activate the lighting system. The light symbol will be shown on the LCD screen.
- Press the lights button again to turn the lighting system off.



**WARNING!** Scooter users are required to use their lights when visibility is restricted—day or night.

### LCD Screen and Control Panel Settings

The LCD control panel offers easily intuited feedback information via the LCD screen. See figure 4. The LCD screen is also used during the set-up (activation) of the various control panel settings.

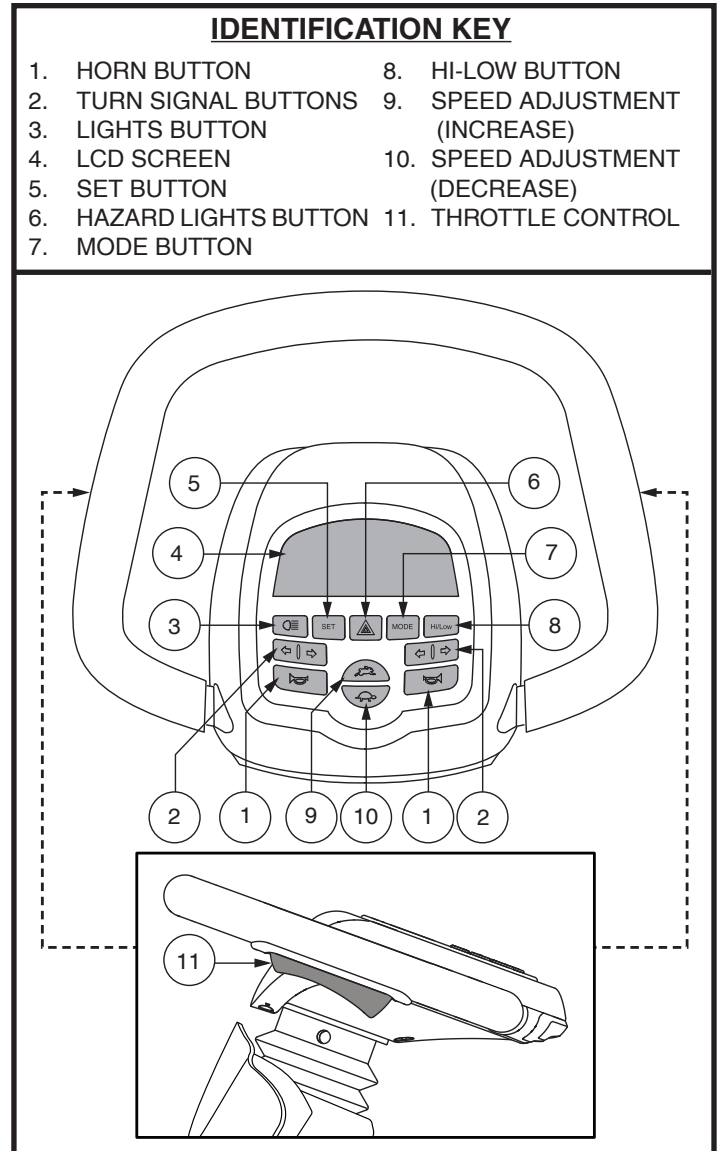

Figure 4. LCD Control Panel - Style B

## II. YOUR SCOOTER

### Hazard Lights Button

This button activates the 4-way yellow flashers on your scooter.

- Press the button once to turn on the flashers.
- Press the button again to turn off the flashers.

*NOTE: The 4-way flashers will flash and a warning beep will sound as long as the hazard lights are on. See figure 6 for volume control.*

### Mode Button

Use the mode button to scroll between the odometer, tripometer, temperature, and clock (Style B) and odometer, tripometer, clock and brightness display (Style C).

### High-Low Button

This button toggles the scooter's speed between HIGH and LOW.

- Press the High-Low button once to set the speed adjustment to High. The High-Low indicator will display on the LCD screen. **See figure 5.** Using this setting in conjunction with the speed adjustment buttons will allow the scooter to achieve speeds up to the maximum preprogrammed speed for the scooter.
- Press the High-Low button again to set the speed adjustment to Low. The High-Low indicator will not display on the LCD screen. Using this setting in conjunction with the speed adjustment buttons will allow the scooter to achieve speeds up to the half the maximum preprogrammed speed for the scooter.

### Speed Adjustment Buttons

These adjustment buttons enable you to pre-select and limit your scooter's speed. This is indicated by the maximum speed indicator on the LCD screen. **See figure 5.**

- Press the image of the **tortoise** to decrease the speed of the scooter.
- Press the image of the **hare** to increase the speed of the scooter.

*NOTE: The more bars shown on the maximum speed indicator, the faster your pre-selected maximum speed will be. See figure 5.*

### Throttle Control Levers

These levers allow you to control the forward speed and the reverse speed of your scooter up to the maximum speed you preset with the speed adjustment buttons. A throttle control lever is located on the underside of the left and right side of the tiller handle. **See Figure 4.**

#### To Move Forward:

- Squeeze the rear part of the throttle control lever.

#### To Move Rearward:

- Squeeze the front part of the throttle control lever.

Release the throttle control lever and allow your scooter to come to a complete stop before engaging the other side of the lever. When the throttle control lever is completely released, it automatically returns to the center "stop" position and engages your scooter's brakes.

# II. YOUR SCOOTER

## LCD SCREEN AND CONTROL PANEL SETTINGS

The LCD control panel offers easily intuited feedback information via the LCD screen. See figure 5. The LCD screen may also be used during the set-up (activation) of the various control panel settings. See chart 1.

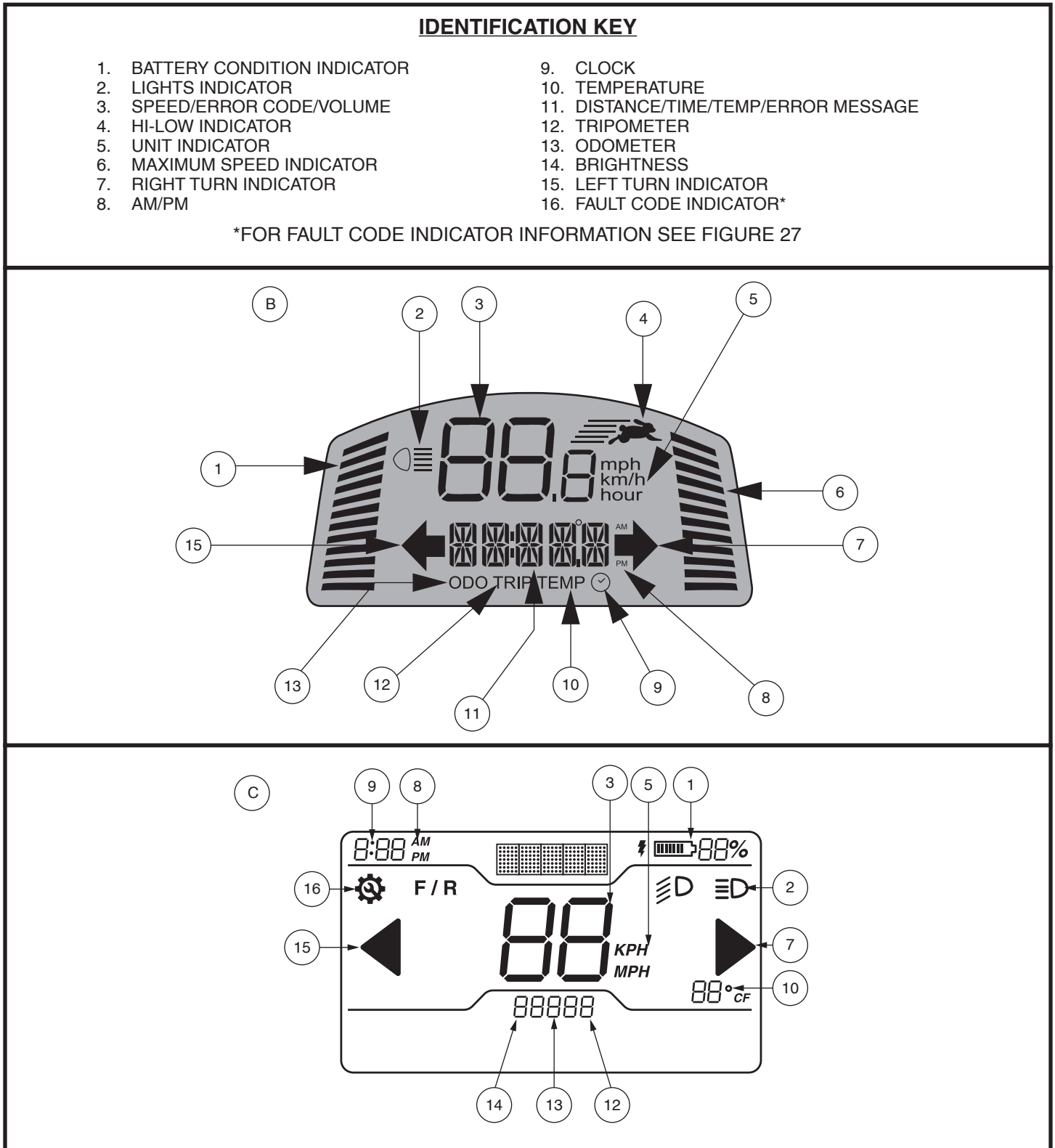



Figure 5. LCD Screen - Console Style B (Top) and Console Style C (Bottom)

## II. YOUR SCOOTER

### SETTING INFORMATION CHART

SETTING	CODE	INFORMATION
Odometer	<b>ODO</b>	Measures mph, km/h, and hours of use. Also displays total distance traveled over life of scooter. (Cannot be reset.)
Tripometer	<b>TRIP</b>	Displays trip distance traveled. Can be reset to "0".
Temperature	<b>TEMP</b>	Displays current temperature in °F or °C.
Clock		Displays time in 12-hour (AM/PM) or 24-hour.
Brightness (style C Only)	<b>000</b>	Allows user to alternate between levels of brightness for LCD Screen.

**Chart 1. LCD Control Panel Information**

Press **MODE** until the setting you want to change appears on the LCD screen. Press and hold **SET** then follow the steps corresponding to your setting in **chart 2**.

SETTING	ODO	TRIP	TEMP	
<b>OPERATION</b>	Press the <b>MODE</b> button until <b>ODO</b> option appears.	Press the <b>MODE</b> button until <b>TRIP</b> option appears.	Press the <b>MODE</b> button until <b>TEMP</b> option appears.	Press and hold <b>MODE</b> button until the clock symbol appears on screen.
<b>SELECTION</b>	Press and hold <b>SET</b> , then simultaneously press the <b>MODE</b> button until the setting option flashes. Scroll through the options by pressing the <b>SET</b> button.	Press and hold <b>SET</b> , then simultaneously press the <b>MODE</b> button for 2 seconds and release. Press and hold <b>SET</b> until Tripometer resets to 0.0.	Press and hold <b>SET</b> , then simultaneously press the <b>MODE</b> button until the setting option flashes. Scroll through the options (°F or °C) by pressing <b>SET</b> button.	Press and hold <b>SET</b> , then simultaneously press the <b>MODE</b> button until the hour digit flashes. Use the <b>SET</b> button to increase the hour to the correct number. Continue to use the <b>MODE</b> and <b>SET</b> buttons to program the minutes and AM/PM setting.
<b>EXIT</b>	When desired option flashes, press any button except <b>SET</b> to exit.	Press any button except <b>SET</b> to exit.	When your choice is flashing, press any button except <b>SET</b> to exit.	Press any button except <b>MODE</b> or <b>SET</b> to exit.

**Chart 2. LCD Control Panel Information - Style B**

# II. YOUR SCOOTER

SETTING	TRIP	BRIGHTNESS	UNIT OF MEASURE	
<b>OPERATION</b>	Press the <b>MODE</b> button until <b>TRIP</b> option appears.	Press the <b>MODE</b> button until <b>000</b> option appears.	Press and hold the <b>MODE</b> button until <b>ODO</b> option appears.	Press <b>MODE</b> button until the <b>ODO</b> symbol appears on screen.
<b>SELECTION</b>	Press and hold <b>MODE</b> until Tripometer resets to 0.0.	Press and hold the <b>MODE</b> button until <b>000</b> flashes. Press <b>MODE</b> to toggle between LCD Screen brightness settings (100%, 75%, 50%) until desired brightness is reached.	Press and hold until Distance/ Temperature flashes. Scroll through the options (°F or °C/Miles or Kilometers) by pressing <b>MODE</b> button.	Press and hold the <b>MODE</b> button once (1) for unit of measure. Press and Hold <b>MODE</b> twice (2) to switch between AM/PM by pressing <b>MODE</b> button. Press and hold the <b>MODE</b> button a third (3) time to set the hour by pressing the <b>MODE</b> button before pressing and holding the <b>MODE</b> button a fourth (4) time to adjust and set the minute by pressing the <b>MODE</b> button.
<b>EXIT</b>	N/A	Press and hold <b>MODE</b> button to exit.	Press and hold the <b>MODE</b> button to move to Time Settings.	Press and hold the <b>MODE</b> button to exit.

Chart 3. LCD Control Panel Information - Style C

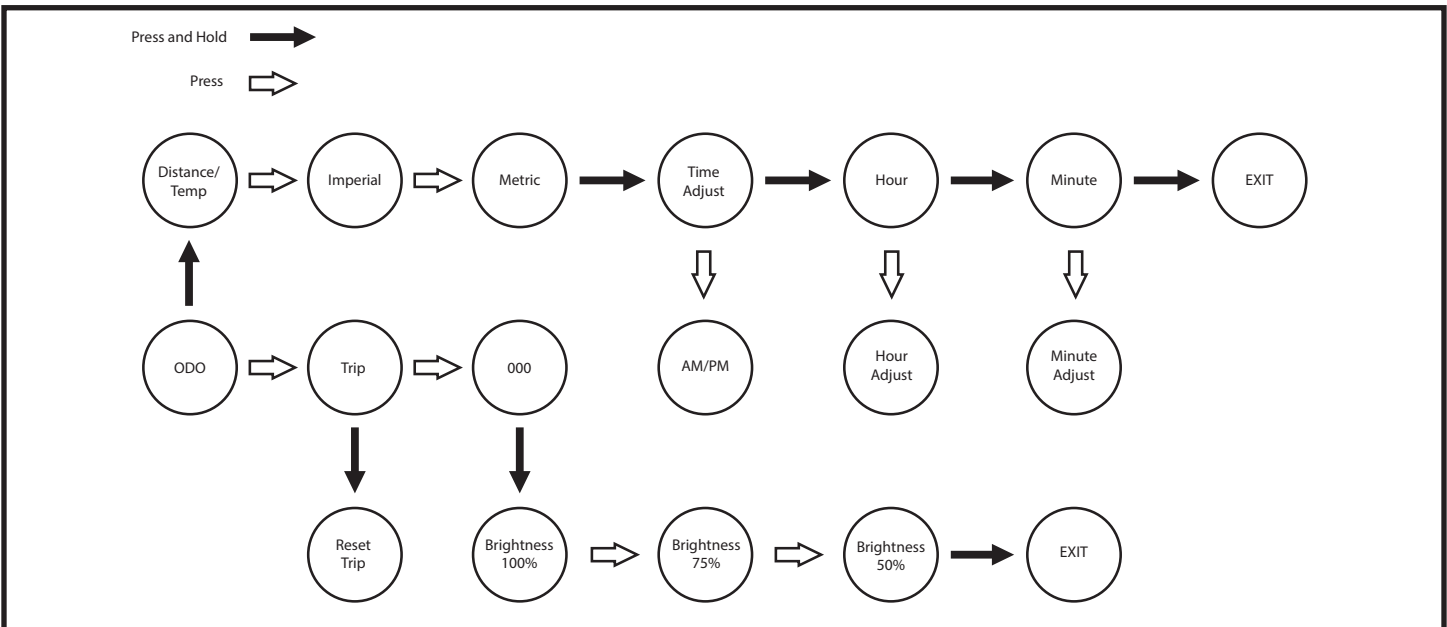

Chart 4. LCD Control Panel Information - Style C - Flowchart

## Battery Charging Mode

During battery charging, the console will display the clock and the battery condition indicator.

## Battery Condition Indicator

When the key is turned to the “on” position, this indicator gives an approximate reading of battery strength. When the scooter’s battery voltage reaches a low enough level, a warning beep will sound once, indicating the batteries need charging. The warning beep will not sound again until the scooter is restarted or the throttle control lever is pressed.

## Mode Button

Use the mode button to scroll between the odometer, tripometer, temperature, and clock (Style B) and odometer, tripometer, clock and brightness display (Style C). See Figure 7. Through a series of presses and holds, you can change the settings on your console. See Chart 3 for more information.

## II. YOUR SCOOTER

### Maximum Speed Indicator

The maximum speed indicator displays the maximum speed selected with the speed adjustment buttons. The more bars that are lit, the faster the speed. The maximum scooter speed will be determined by the HIGH-LOW setting, which limits the maximum speed to half when set to LOW. The actual travel speed will be shown in the speed display on the LCD screen.

### Volume Control

Turn signals, hazard lights, low voltage, and error messages can be set to both blink and beep. The horn is relay operated and its volume cannot be adjusted. See **figure 6**.

#### To set the volume:

1. Ensure the key is in the “off” position.
2. Press the appropriate two buttons simultaneously (see **chart 5**), and turn the key to the “on” position.
3. Once the volume control screen appears, release the buttons.
4. Press the hare button to increase the volume to a value of 4 and the tortoise button to decrease the volume of the beep to 0 (0 indicates off and 4 indicates the loudest volume).
5. To exit, press any button except the **hare** or **tortoise**.

**NOTE:** The error message language option is set the same way as the volume.

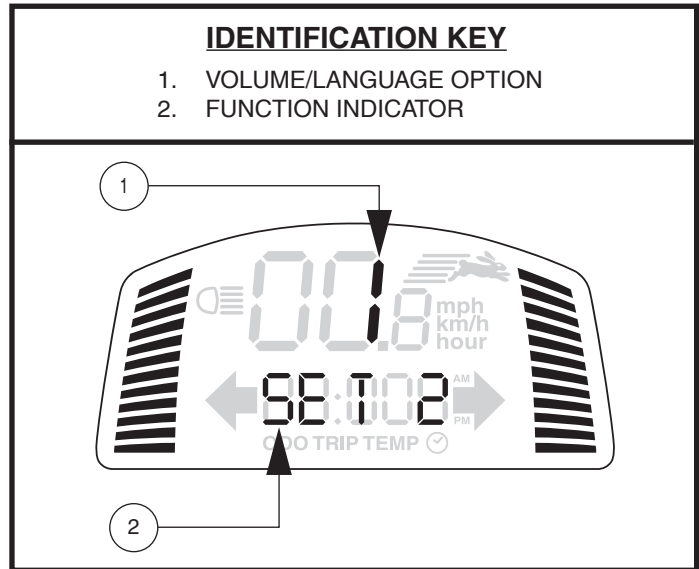

**Figure 6. Volume Control Display**

FUNCTION	BUTTONS	FUNCTION INDICATOR
Hazard Lights	SET + HAZARD LIGHTS	SET 1
Low Voltage	SET + LEFT TURN INDICATOR	SET 3
Turn Signals	SET + RIGHT TURN INDICATOR	SET 4
Error Message Language Option	SET + LIGHTS	SET 5 6 - <b>Spanish</b> 5 - <b>Italian</b> 4 - <b>French</b> 3 - <b>German</b> 2 - <b>Dutch</b> 1 - <b>English</b> 0 - <b>Close</b>

**Chart 5. Volume Control Information**

# II. YOUR SCOOTER

## IDENTIFICATION KEY

- |                             |                              |
|-----------------------------|------------------------------|
| 1. HAND BRAKE LEVER         | 9. HORN BUTTON               |
| 2. HORN BUTTON              | 10. LEFT TURN SIGNAL BUTTON  |
| 3. RIGHT TURN SIGNAL BUTTON | 11. THROTTLE CONTROL LEVER   |
| 4. HEADLIGHT SWITCH         | 12. THROTTLE CONTROL LEVER   |
| 5. LCD SCREEN**             | 13. RIGHT TURN SIGNAL BUTTON |
| 6. SPEED ADJUSTMENT DIAL    | 14. MODE BUTTON              |
| 7. HAZARD SWITCH            | 15. *THROTTLE CONTROL PADDLE |
| 8. LEFT TURN SIGNAL BUTTON  |                              |

\*OPTIONAL COMPONENTS AVAILABLE ON SOME MODELS

\*\*FOR LCD SCREEN INFORMATION SEE FIGURE 5.

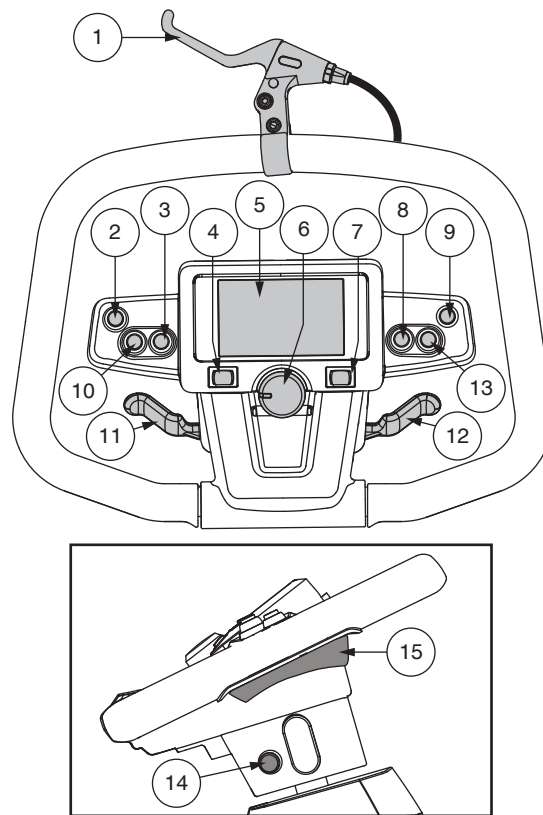

Figure 7. Tiller Console Components - Style C

### Horn Buttons

These buttons activate a warning horn. Your scooter must be powered up for the horn to be operational. Do not hesitate to use the warning horn when doing so may prevent accident or injury.

### Turn Signal Buttons

Use these buttons to turn on the left and right turn signal (amber) lights.

- Push the left button to activate the left turn signal light. The turn signal indicator located in the LCD screen will flash.
- Push the right button to activate the right turn signal light. The turn signal indicator located in the LCD screen will flash.
- The turn signals are timed to shut off automatically.

## II. YOUR SCOOTER

### Power Button (Optional – For use with NFC Card Reader)

The power button allows you to turn your scooter on and off.

- Press the power button to turn your scooter on and to use the NFC card reader. Once fully engaged and latched, the power button will emit a blue light. The power button is used in conjunction with the NFC card reader for additional security for your scooter. See “NFC Card Reader” for more information.
- Press the power button again to power down (turn off) your scooter.



**WARNING! When faced with an emergency situation, switch off the key to power off the scooter. Use caution. Be advised that turning off power to the scooter may cause the scooter to stop abruptly. To release the emergency stop and restore driving capability to the scooter, release the throttle control lever and then switch on the key to the scooter.**

**WARNING! If power button is pushed while your scooter is in motion, the electronic brakes will engage and your scooter will come to an abrupt stop.**

### NFC Card Reader (Optional)

The Near Field Communication (NFC) card reader provides additional security for your scooter as no 2 keys are the same. The NFC card reader enables you to turn on your scooter with the added security of Near Field Communication (NFC).

#### To use the NFC card reader:

1. Press the power button on the scooter until it is fully engaged and latched.
2. Hold the NFC card over the card reader.
3. A 4-note audible sound will indicate successful pairing of the NFC card and your scooter.
4. The key may now be placed in a safe place while operating your scooter.
5. The scooter may now be driven.

**NOTE: Once the power button is fully engaged and latched, you will have ten (10) seconds to pair the NFC card with your scooter. If you are unable to pair your scooter, press the power button to turn off your scooter, wait ten (10) seconds, and then press the power button to turn your scooter back on to try again.**

6. To power down (turn off) your scooter, press the power button again.

### Lights Switch

This switch controls your scooter’s lighting system.

- Toggle the switch to the right to turn on the lighting system.
- Toggle the switch to the left to turn off the lighting system.



**WARNING! Scooter users are required to use their lights when visibility is restricted—day or night.**

### Hazard Lights Switch

This switch activates the 4-way flashers on your scooter.

- Toggle the hazard lights switch to the right to turn on the flashers.
- Toggle the hazard lights switch to the left to turn off the flashers.

### Speed Adjustment Dial

This dial allows you to preselect and limit your scooter’s top speed.

- The image of the **tortoise** represents the slowest speed setting
- The image of the **hare** represents the fastest speed setting.

## II. YOUR SCOOTER

### Throttle Control Lever

This lever allows you to control the forward speed and the reverse speed of your scooter up to the maximum speed you preset with the speed adjustment dial.

**NOTE:** *The throttle control lever operation instructions outlined below apply to scooters in a standard configuration. If the programming of your scooter was modified in any way by an authorized provider, contact that provider for correct throttle control level operation instructions.*

#### To Move Forward, use either of the following:

- Use your left thumb to push the left side of the throttle control lever.
- Use your right hand fingers to pull back on the right side of the throttle control lever.

#### To Move Rearward, use either of the following:

- Use your right thumb to push the right side of the throttle control lever.
- Use your left hand fingers to pull back on the left side of the throttle control lever.

Release the throttle control lever and allow your scooter to come to a complete stop before engaging the other side of the lever. When the throttle control lever is completely released, it automatically returns to the center “stop” position and engages your scooter’s brakes.

If not equipped with toggles, use the following directions for throttle control paddles:

These paddles allow you to control the forward speed and the reverse speed of your scooter up to the maximum speed you preset with the speed adjustment buttons. A throttle control paddle is located on the underside of the left and right side of the tiller handle. **See Figure 7.**

#### To Move Forward:

- Squeeze the rear part of the throttle control paddle.

#### To Move Rearward:

- Squeeze the front part of the throttle control paddle.

Release the throttle control paddle and allow your scooter to come to a complete stop before engaging the other side of the paddle. When the throttle control paddle is completely released, it automatically returns to the center “stop” position and engages your scooter’s brakes.

### Handbrake Lever

This lever provides you with supplemental stopping power. When in motion, release the throttle control lever and gently squeeze the handbrake lever to come to a stop. Handbrake effectiveness can be modified by tightening or loosening the setscrew located on the handbrake lever.



**WARNING! The handbrake is intended for use as a supplemental braking.**

## II. YOUR SCOOTER

**LOWER TILLER** (available on models 123, 124, 133, 134, 143, 144, 614, 714, 3120, 3130 and 3140 only)

### Off-board Charger Port

The off-board charger power cord plugs into this port during battery charging. The off-board charger port will be located on the tiller. See **figure 8**.

### Electrical System Fuses

For information and a complete description of the fuse system, see **figure 2**.

### Tiller Adjustment Lever or Tiller Adjustment Knob

See V. "Comfort Adjustments".

### Key Switch

- Insert the key into the key switch and turn it clockwise to power up (turn on) your scooter. See **figure 8**.
- Turn the key counterclockwise to power down (turn off) your scooter.

**WARNING!** When faced with an emergency situation, switch off the key to power off the scooter. Use caution. Be advised that turning off power to the scooter may cause the scooter to stop abruptly. To release the emergency stop and restore driving capability to the scooter, release the throttle control lever and then switch on the key to the scooter.



**WARNING!** If the key is turned to the "off" position while your scooter is in motion, the electronic brakes will engage and your scooter will come to an abrupt stop!

### Throttle Control Lever Switch

This switch dictates which throttle control lever (left or right) will function. See **figure 8**.

- Toggle the switch up to activate the left throttle control lever.
- Toggle the switch down to activate the right throttle control lever.

### IDENTIFICATION KEY

1. OFF-BOARD CHARGER PORT
2. FUSE PANEL
3. TILLER ADJUSTMENT KNOB
4. KEY SWITCH
5. \*THROTTLE CONTROL LEVER SWITCH
6. WATER BOTTLE HOLDER
7. MIRROR
8. USB CHARGER

\*OPTIONAL COMPONENTS AVAILABLE ON SOME MODELS

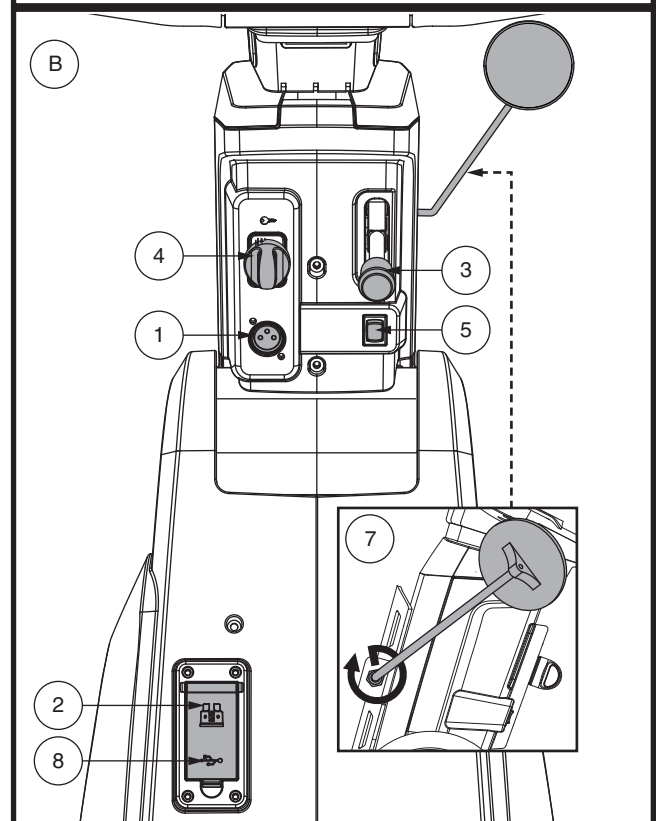
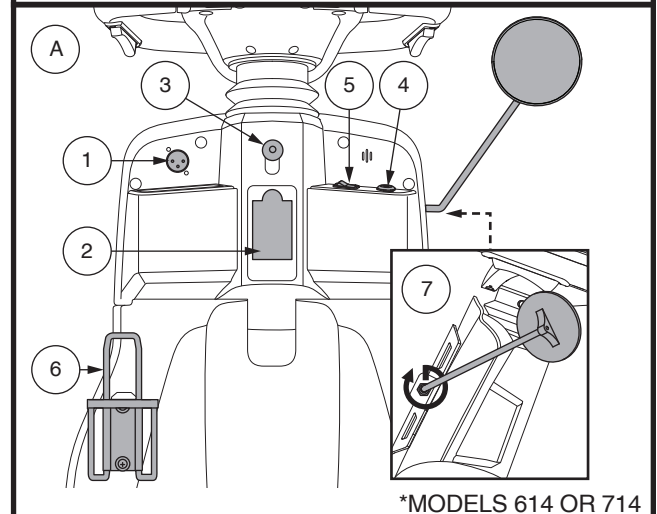

Figure 8. Lower Tiller Components

## II. YOUR SCOOTER

### For Models 614 and 714:

- Toggle the switch to the left to activate the left throttle control lever.
- Toggle the switch to the right to activate the right throttle control lever.

**NOTE:** Only one throttle control lever will function at a time.

### Water Bottle Holder

The water bottle holder is intended to hold a standard size, plastic water bottle. The holder can be attached to either side of the scooter using the supplied hardware.

### REAR COMPONENTS

The manual freewheel lever, anti-tip wheels (if equipped), motor/transaxle assembly, and optional safety flag brackets are located on your scooter as shown. See figure 9. The main circuit breaker (reset button) and batteries (not shown) are also located on the rear component section of your scooter.



**WARNING!** Before placing your scooter into or taking it out of freewheel mode, remove the key from the key switch. Never sit on a scooter when it is in freewheel mode. Never put a scooter in freewheel mode on any incline.

### Manual Freewheel Lever

Whenever you need or want to push your scooter for short distances, you can put it in freewheel mode.

1. Remove the key from the key switch.
2. Push forward on the manual freewheel lever to disable the drive system and the brake system. This will enable you to push the scooter.
3. Pull back on the manual freewheel lever to reengage the drive and the brake systems and take your scooter out of freewheel mode.



**WARNING!** When your scooter is in freewheel mode, the braking system is disengaged.

- Disengage the drive motors only on a level surface.
- Ensure the key is removed from the key switch.
- Stand to the side of the scooter to engage or disengage freewheel mode. Never sit on a scooter to do this.
- After you have finished pushing your scooter, always return it to the drive mode to lock the brakes.

**NOTE:** If the scooter is placed in freewheel mode (manual freewheel lever forward) while the key is in the “on” position, the scooter will not run until the manual freewheel lever is pushed backward and the key is turned to the “off” position, then back to the “on” position.

### IDENTIFICATION KEY

1. MANUAL FREEWHEEL LEVER
2. MOTOR/TRANSAXLE ASSEMBLY
3. ANTI-TIP WHEELS (if equipped)
4. SAFETY FLAG BRACKETS

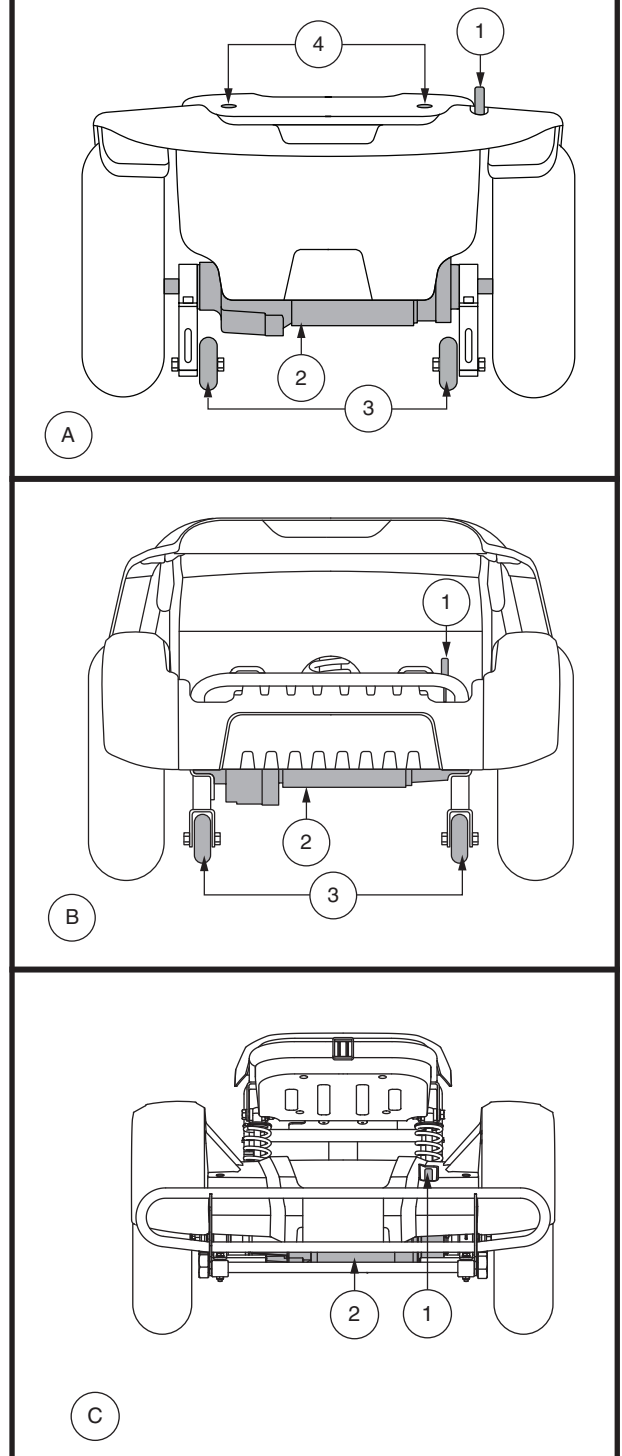

Figure 9. Rear Components

## II. YOUR SCOOTER

### Motor/Transaxle Assembly

The motor/transaxle assembly is an electromechanical unit that converts electrical energy from your scooter's batteries into the controlled mechanical energy that drives the scooter's wheels.

### Anti-Tip Wheels (If equipped)

The anti-tip wheels are an integral and important safety feature of your scooter. They are bolted to the frame at the rear of the scooter.



**PROHIBITED!** Do not remove the anti-tip wheels or modify your scooter in any way that is not authorized by your Provider.



**WARNING!** The anti-tip wheels may cause interference with the smooth transition of your scooter when ascending or descending a curb. Contact your authorized Provider for more information.

### Batteries

The batteries store electrical energy that powers your scooter. See III. "Batteries and Charging" for information on how to charge your scooter batteries.

### Safety Flag Bracket (Optional—Models 613/713/7132/713ES)

Accessory brackets for installing an optional safety flag are mounted at the rear of the scooter. See figure 9.

#### To install the safety flag:

1. Remove the cap from the top of the bracket.
2. Insert the flag pole into the opening.

### Main Circuit Breaker

When the voltage in the batteries becomes low or your scooter is heavily strained because of excessive loads, the main circuit breaker may trip to protect the motor and electronics from damage. When the breaker trips, the entire electrical system shuts down. See figure 10.

- Three types:
  1. **Reset lever** flips down when the breaker trips.
  2. **Reset button** pops out when the breaker trips.
  3. **Automatic reset type** will reset itself after approximately a minute or so.
- Allow a minute or so for the electronics to "rest."
- Push the reset lever up until you hear a click, or push in the reset button to reset the breaker.
- If the breaker trips frequently, you may need to charge the batteries more often.
- If the main circuit breaker trips repeatedly, see your authorized Provider for service.

#### IDENTIFICATION KEY

1. LEVER STYLE
  - a. reset lever
  - b. manual shut-off button
2. RESET BUTTON STYLE
3. AUTOMATIC RESET STYLE (MODELS 614 OR 714)

1

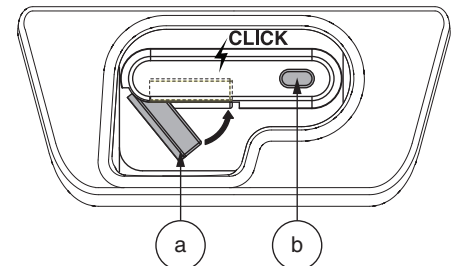

2

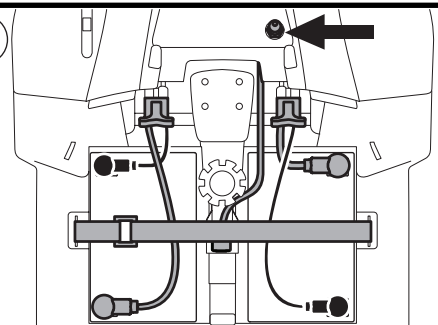

3

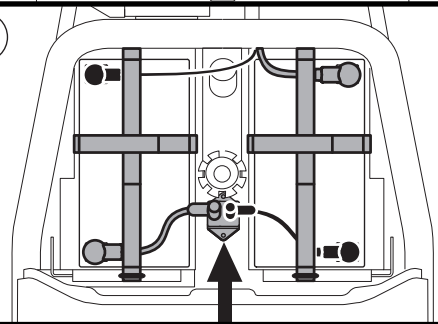

4

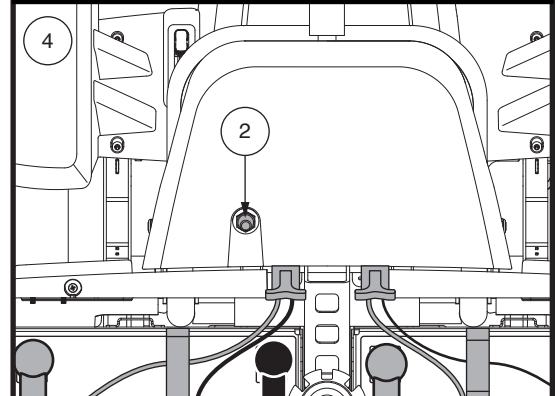

Figure 10. Main Circuit Breaker

## II. YOUR SCOOTER

**NOTE:** If you are preparing your scooter for transport or service, or if there is a situation that requires you to manually shut down the electrical system, press the manual shut-off button on the circuit breaker. This will cut all power to your scooter.

### SECUREMENT POINTS

Always secure the scooter in a forward-facing position in the vehicle. Attach the four tie-down straps to the designated securement points. See figures 11 and 12. Tighten the straps to sufficiently remove all slack. Never attach tie-downs to adjustable, moving, or removable parts of the scooter such as armrests, shrouds, and wheels. These items should be removed. Position the anchor points for the rear tie-down straps directly behind the rear securement points on the scooter. The front tie-down straps should anchor to floor points that are spaced wider than the scooter to provide increased lateral stability.



**WARNING!** Ensure scooters are properly secured to the motor vehicle during transport. Scooters that are not properly secured can become a hazard to the user and to other vehicle passengers in the event of a crash, sudden stopping, or swerving, as the scooter could tip or slide out of place.

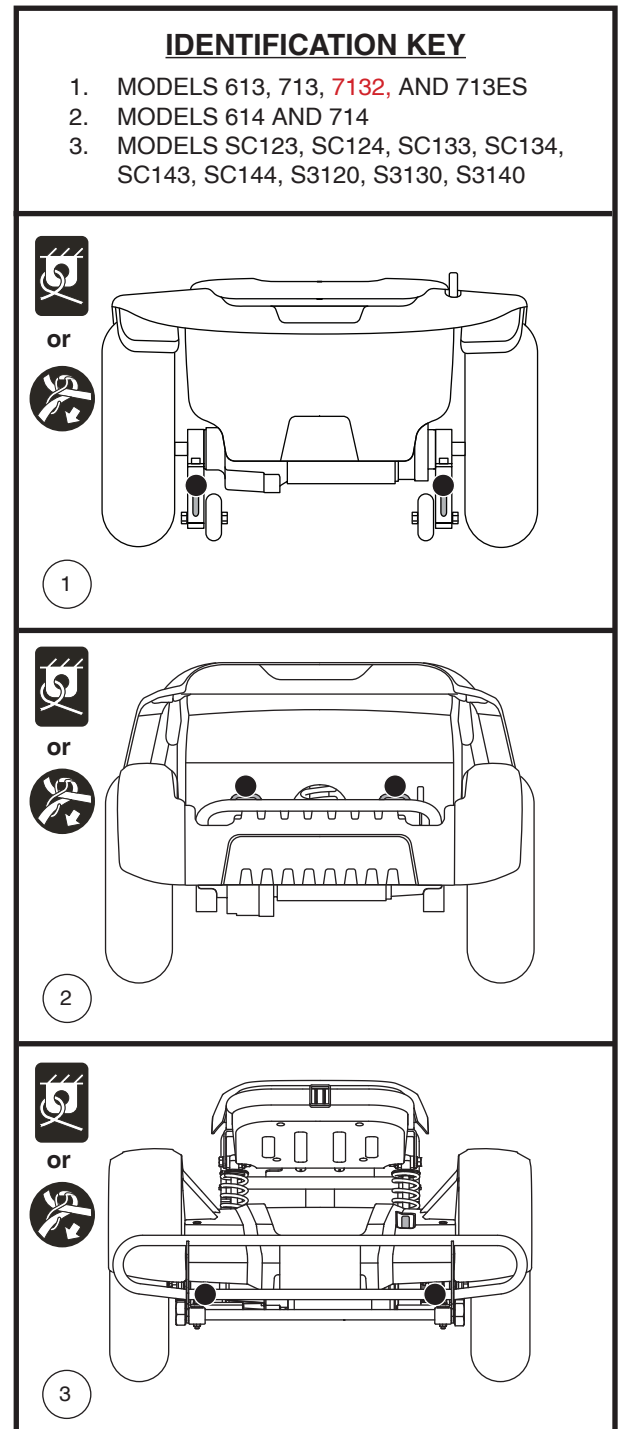

Figure 11. Rear Securement Points (Identified with black dots)

## II. YOUR SCOOTER

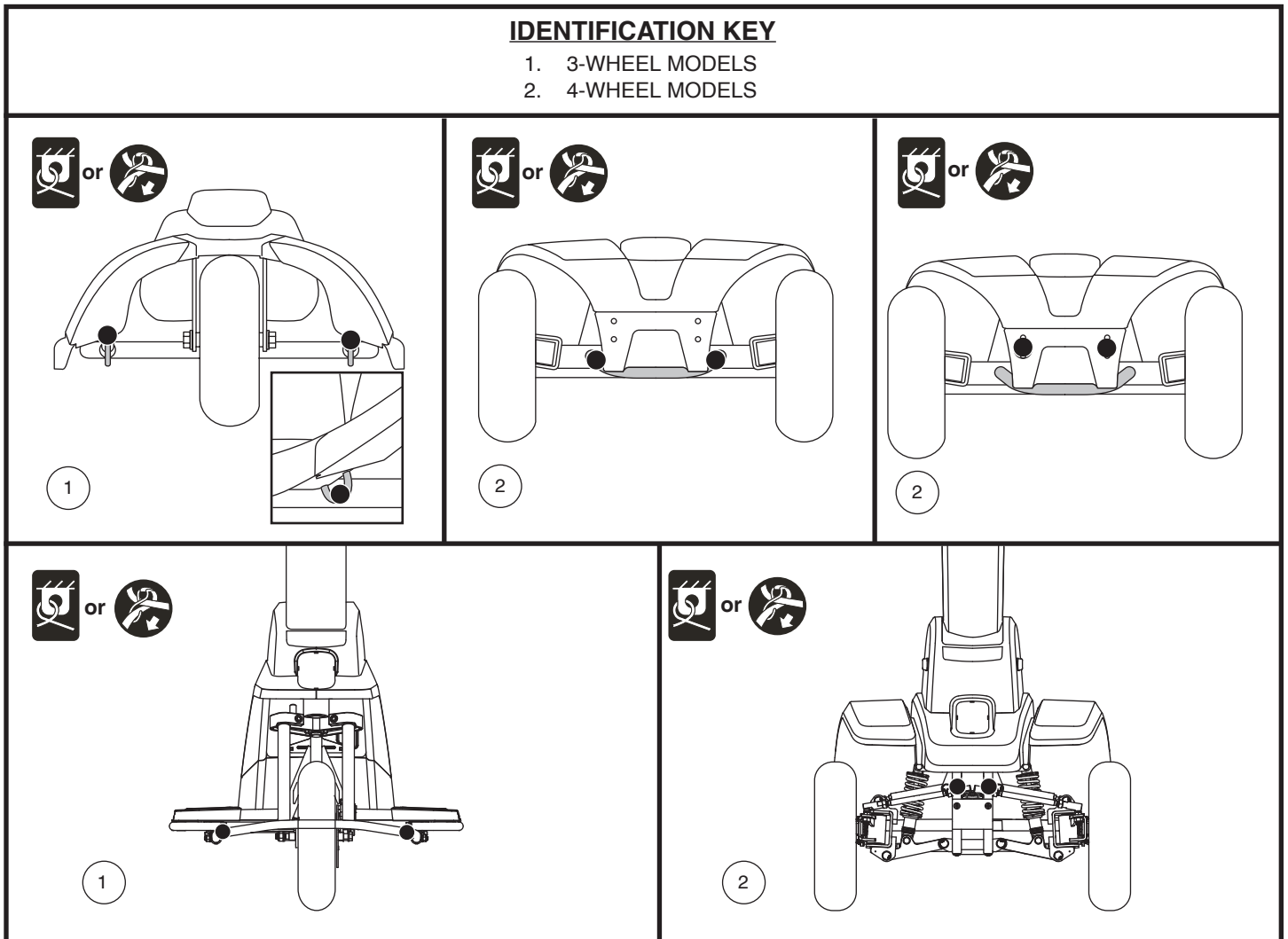

Figure 12. Front Securement Points (Identified with black dots)

# III. BATTERIES AND CHARGING

## BATTERIES AND CHARGING

Your scooter requires two long-lasting, 12-volt, deep-cycle batteries that are sealed and maintenance free. They are recharged by an off-board charging system.

- Charge your scooter's batteries for at least 8 to 14 hours prior to using it for the first time.
- Keep the batteries fully charged to keep your scooter running smoothly.

## READING YOUR BATTERY VOLTAGE

The battery condition meter on the tiller console indicates the approximate strength of your batteries using a color code. From right to left, green indicates fully charged batteries, yellow indicates a draining charge, and red indicates that an immediate recharge is necessary. **See figure 13.** To ensure the highest accuracy, the battery condition meter should be checked while operating your scooter at full speed on a dry, level surface. For models with the LCD screen, please refer to the "Battery Condition Indicator" section on page 15.

For models equipped with battery condition meter 1c, the battery condition meter on the tiller console indicates the approximate strength of your batteries using a color code. From right to left on the meter, green (5 LEDs) indicates fully charged batteries, yellow (3 LEDs) a draining charge, and red (2 LEDs) indicates that an immediate recharge is necessary. **See figure 13.** To ensure the highest accuracy, the battery condition meter should be checked while operating your vehicle at full speed on a dry, level surface. When 5 LEDs (2 red LEDs and 3 yellow LEDs) are displayed, your batteries have 10% charge remaining.

**NOTE:** Battery condition meter 1c adjusts brightness based on environmental lighting.

## CHARGING YOUR BATTERIES



**PROHIBITED!** Removal of grounding prong can create electrical hazard. If necessary, properly install an approved 3-pronged adapter to an electrical outlet having 2-pronged plug access.



**PROHIBITED!** Never use an extension cord to plug in your battery charger. Plug the charger directly into a properly wired standard electrical outlet.



**PROHIBITED!** Do not allow unsupervised children to play near the scooter while the batteries are charging. We recommend that you do not charge the batteries while the scooter is occupied.



**MANDATORY!** Read the battery charging instructions in this manual and in the manual supplied with the battery charger before charging the batteries.

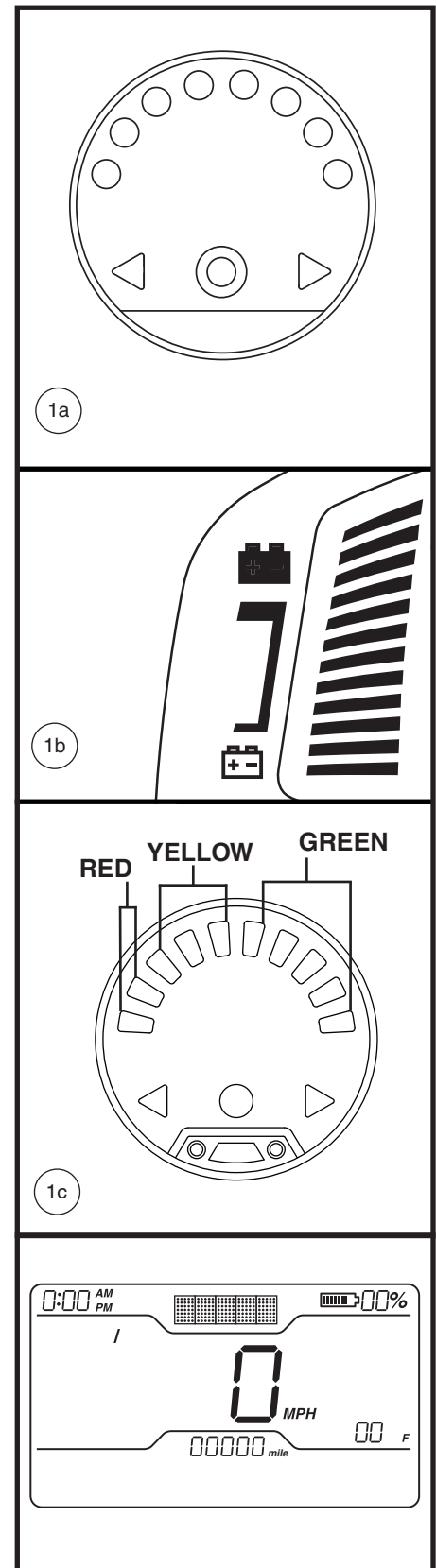

Figure 13. Battery Condition Meter

# III. BATTERIES AND CHARGING



**WARNING!** Explosive gases may be generated while charging the batteries. Keep the scooter and battery charger away from sources of ignition such as flames or sparks and provide adequate ventilation when charging the batteries.

**WARNING!** You must recharge your scooter's batteries with the supplied off-board charger. Do not use an automotive-type battery charger.

**WARNING!** Inspect the battery charger, wiring, and connectors for damage before each use. Contact your authorized Provider if damage is found.



**WARNING!** Do not attempt to open the battery charger case. If the battery charger does not appear to be working correctly, contact your authorized Provider.

**WARNING!** If the battery charger is equipped with cooling slots, then do not attempt to insert objects through these slots.

**WARNING!** Be aware that the battery charger case may become hot during charging. Avoid skin contact and do not place on surfaces that may be affected by heat.



**WARNING!** If your battery charger has not been tested and approved for outdoor use, then do not expose it to adverse or extreme weather conditions. If the battery charger is exposed to adverse or extreme weather conditions, then it must be allowed to adjust to the difference in environmental conditions before use indoors. Refer to the manual supplied with the battery charger for more information.

*Follow these easy steps to charge the batteries:*

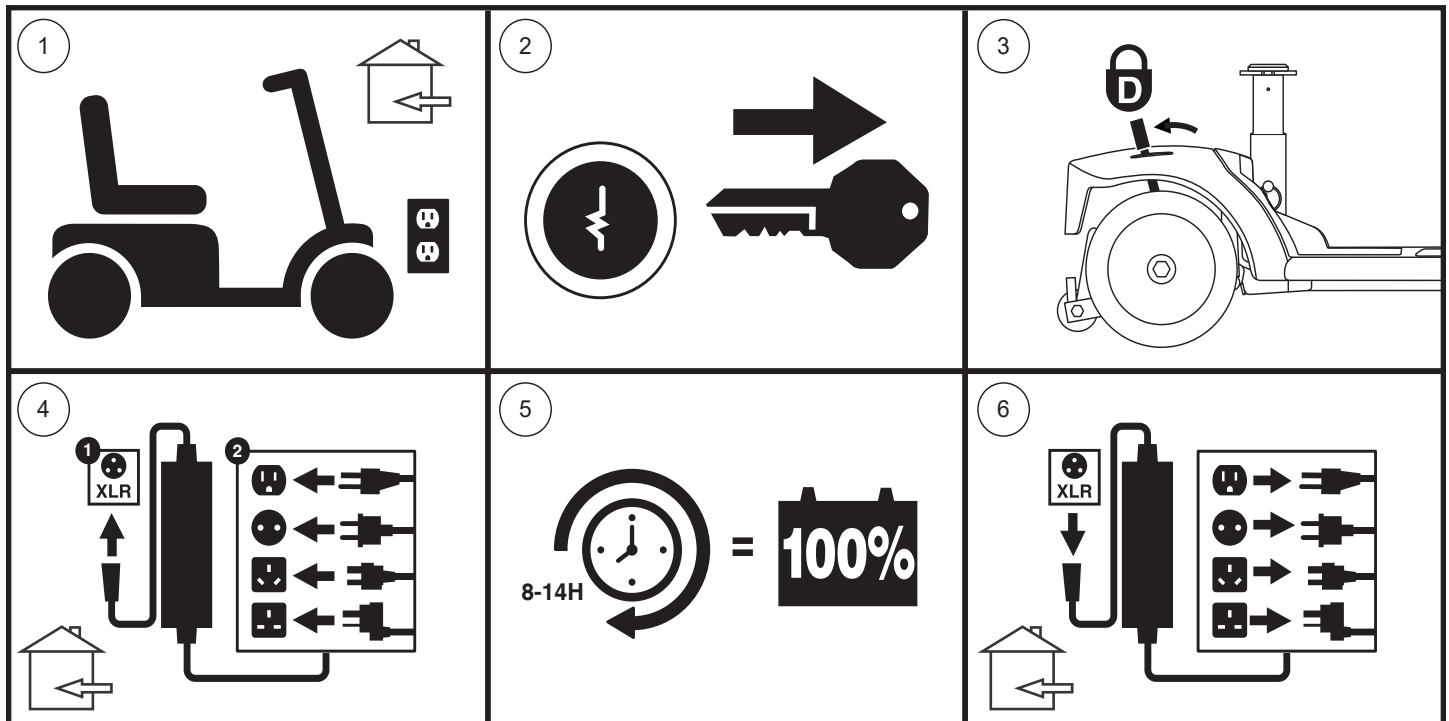

Figure 14. Battery Charging Procedures Diagram

# III. BATTERIES AND CHARGING



**WARNING!** The LED lights on the charger indicate different charger conditions at various times. If the LED does not indicate that charging is complete within 24 hours, unplug the charger from the outlet and contact your Provider. Refer to the operating instructions supplied with the charger for a complete explanation of these indicators.

*NOTE: There is a charger inhibit function on your scooter. The scooter will not run and the battery condition meter will not operate while the batteries are charging.*

## FREQUENTLY ASKED QUESTIONS

### How does the charger work?

When your scooter's battery voltage is low, the charger works harder, sending more electrical current to the batteries to bring up their charge. As the batteries approach a full charge, the charger sends less and less electrical current. When the batteries are fully charged, the current sent from the charger is at nearly zero amperage. Therefore, when the charger is plugged in, it maintains the charge on your scooter's batteries, but does not overcharge them. Refer to the manual supplied with the battery charger for charging instructions.

### Can I use a different charger?

Chargers are selected precisely for particular applications and are especially matched to the type, size and chemical formulation of specific batteries. For the safest and most efficient charging of your scooter's batteries we recommend only use of the charger supplied as original equipment with your product. Any charging method resulting in batteries being charged individually is especially prohibited.

### What if my scooter's batteries won't charge?

- Ensure the red (+) and black (-) battery cables are connected properly to the battery terminals.
- Ensure both ends of the charger power cord are inserted fully.
- Ensure the circuit breaker is not tripped.

### How often must I charge the batteries?

Two major factors must be considered when deciding how often to charge your scooter's batteries:

- All day scooter use on a daily basis.
- Infrequent or sporadic scooter use.

With these considerations in mind, you can determine how often and for how long you should charge your scooter's batteries. The battery charger was designed so that it will not overcharge your scooter's batteries. However, you may encounter some problems if you do not charge your batteries often enough and if you do not charge them on a regular basis. Following the guidelines below will provide safe and reliable battery operation and charging.

- If you use your scooter daily, charge its batteries as soon as you finish using it for the day. Your scooter will be ready each morning. We recommend that you charge your scooter's batteries for at least 8 to 14 hours after daily use. We recommend that you charge the batteries for an additional 4 hours after the battery charger indicates that charging is complete.
- If you use your scooter once a week or less, charge its batteries at least once a week for at least 24 hours.

*NOTE: Keep your batteries fully charged and avoid deeply discharging your batteries. Refer to the manual supplied with the battery charger for charging instructions. We recommend charging your batteries for at least 48 continuous hours once per month to improve battery performance and battery life.*

# III. BATTERIES AND CHARGING

## How can I ensure maximum battery life?

Fully charged deep-cycle batteries provide reliable performance and extended battery life. Keep your scooter's batteries fully charged whenever possible. Protect your scooter and batteries from extreme heat or cold. Batteries that are regularly and deeply discharged, infrequently charged, stored in extreme temperatures, or stored without a full charge may be permanently damaged, causing unreliable performance and limited service life.

**NOTE:** *To extend battery life, always turn off scooter and remove the key when not in use.*

## How can I get maximum range or distance per charge?

Rarely will you have ideal driving conditions—smooth, flat, hard driving surfaces with no wind or curves. Often, you will face hills, pavement cracks, uneven and loosely packed surfaces, curves, and wind, all of which affect the distance or running time per battery charge. Below are a few suggestions for obtaining the maximum range per battery charge.

- Always fully charge your scooter's batteries prior to daily use.
- Maintain but do not exceed the psi/bar/kPa air pressure rating indicated on each tire.
- Plan your route ahead to avoid as many hills, cracked, broken, or soft surfaces as possible.
- Limit your baggage weight to essential items.
- Try to maintain an even speed while your scooter is in motion.
- Avoid stop-and-go driving.
- We recommend charging your batteries for at least 48 continuous hours once per month to improve battery performance and battery life.
- Make sure all harness connections are secured properly.

## What type and size of battery should I use?

We recommend deep-cycle batteries that are sealed and maintenance free. Both AGM and Gel-Cell are deep-cycle batteries that are similar in performance. Do not use wet-cell batteries, which have removable caps.



**WARNING! Corrosive chemicals are contained in batteries. Use only AGM or Gel-Cell batteries to reduce the risk of leakage or explosive conditions.**

**NOTE:** *Sealed batteries are not serviceable. Do not remove the caps.*

## Why do my new batteries seem weak?

Deep-cycle batteries employ a different chemical technology than that used in car batteries, nickel-cadmium batteries (nicads) and other common battery types. Deep-cycle batteries are specifically designed to provide power, drain down their charge and then accept a relatively quick recharge.

We work closely with our battery manufacturer to provide batteries that best suit your scooter's specific electrical demands. Fresh batteries are shipped fully charged to our customers. During shipping, the batteries may encounter temperature extremes that can influence their initial performance. Heat diminishes the charge on the battery; cold slows the available power and extends the time needed to recharge the battery.

It may take a few days for the temperature of your scooter's batteries to stabilize and adjust to their new room or ambient temperature. More importantly, it takes a few charging cycles (partial draining followed by full recharging) to establish the critical chemical balance that is essential to a deep-cycle battery's peak performance and long life.

## III. BATTERIES AND CHARGING

**Follow these steps to properly break in your scooter's new batteries for maximum efficiency and service life:**

1. Fully recharge any new battery prior to its initial use. This charging cycle brings the battery up to about 88% of its peak performance level.
2. Operate your new scooter in familiar and safe areas. Drive slowly at first, and do not travel too far from your home or familiar surroundings until you have become accustomed to your scooter's controls and have properly broken in your scooter's batteries.
3. Fully recharge the batteries. They should be at over 90% of their peak performance level.
4. Operate your scooter again, then fully recharge the batteries again.
5. After four or five charging cycles, the batteries are able to receive a charge of 100% of their peak performance level and are able to last for an extended period of time.

### **What about public transportation?**

AGM and Gel-Cell batteries are designed for application in scooters and other mobility vehicles. These batteries are Federal Aviation Administration (FAA) approved (United States only), allowing safe transportation on aircraft, buses, and trains, as there is no danger of spillage or leakage. We suggest you contact the carrier's ticket counter in advance to determine that carrier's specific requirements.

# III. BATTERIES AND CHARGING

How do I change a battery in my scooter?



**MANDATORY!** Battery posts, terminals and related accessories contain lead and lead compounds. Wear goggles and gloves when handling batteries and wash hands after handling.



**PROHIBITED!** Always use two batteries of the exact same type, chemistry and amp-hour (Ah) capacity. Refer to the specifications table with this manual and in the manual supplied with the battery charger for recommended type and capacities.

**WARNING!** Do not mix old and new batteries. Always replace both batteries at the same time.



**WARNING!** Contact your authorized Provider if you have any questions regarding the batteries in your scooter.

**WARNING!** Do not replace the batteries while the scooter is occupied.

**WARNING!** The batteries on your scooter should only be serviced or replaced by an authorized Provider or a qualified technician.



**PROHIBITED!** Keep tools and other metal objects away from battery terminals. Contact with tools can cause electrical shock.

You may need the following to change your batteries:

- Metric/standard socket set and ratchet
- Adjustable wrench
- Screwdriver



**WARNING!** Do not lift beyond your physical capability. Ask for assistance when necessary while disassembling or assembling your scooter.

To change batteries in your scooter:

1. Remove the seat and battery shroud. See figure 15.
  - a.) For models 614 and 714, remove the rear shroud by removing the two (2) thumbscrews that secure it to the scooter frame, and then lifting the shroud straight up and off of the scooter. See figure 15.
  - b.) For models 614 and 714, remove the battery shroud by removing the four (4) thumbscrews that secure it to the scooter frame, and then lifting the shroud straight up and off of the scooter. See figure 15.
2. Disconnect the battery tie-down strap(s).
3. For all models EXCEPT 614 and 714, disconnect the front-to-rear harness. Unplug both battery harnesses by pulling each harness out of its mating plug. See figure 17.



**WARNING!** Do not pull on electrical harness wires directly to detach them from the scooter. Always grasp the connector itself when disconnecting the harness to prevent wire damage.

**WARNING!** Failure to unplug both battery harnesses and front-to-rear harness prior to separating the front and rear sections could result in permanent damage to the scooter.

4. Disconnect the battery cables from the battery terminals by sliding back the terminal boots and unscrewing the nut from the bolt. See figure 16.
5. Remove the old batteries from the battery wells.

**NOTE:** Some scooters have spacers installed to secure the batteries. You may want to remove the spacers for safe keeping until the batteries are replaced in the scooter. See figure 18.

6. Place a new battery in each battery well. Face the battery terminals of each battery away from the seat post with the positive (+) and negative (-) battery terminals positioned as shown in figure 17.

# III. BATTERIES AND CHARGING

**NOTE:** Models 614 and 714 use battery straps to secure batteries in the battery wells. Please refer to figure 17 for battery strap installing procedures.

7. Connect the red battery cable to the positive (+) battery terminal on each battery.
8. Connect the black battery cable to the negative (-) battery terminal on each battery.
9. Reposition the terminal boots over the battery terminals.
10. Reconnect the battery tie-down straps.
11. Reinstall the battery shroud, the rear shroud, and the seat.

**NOTE:** If you encounter a damaged or cracked battery, immediately enclose it in a plastic bag. Contact your local waste disposal agency or your authorized Provider for instructions on disposal and battery recycling, which is our recommended course of action.

**NOTE:** While replacing the batteries in the 7132, you must use the battery jumper harness if using 2 lithium batteries in parallel.

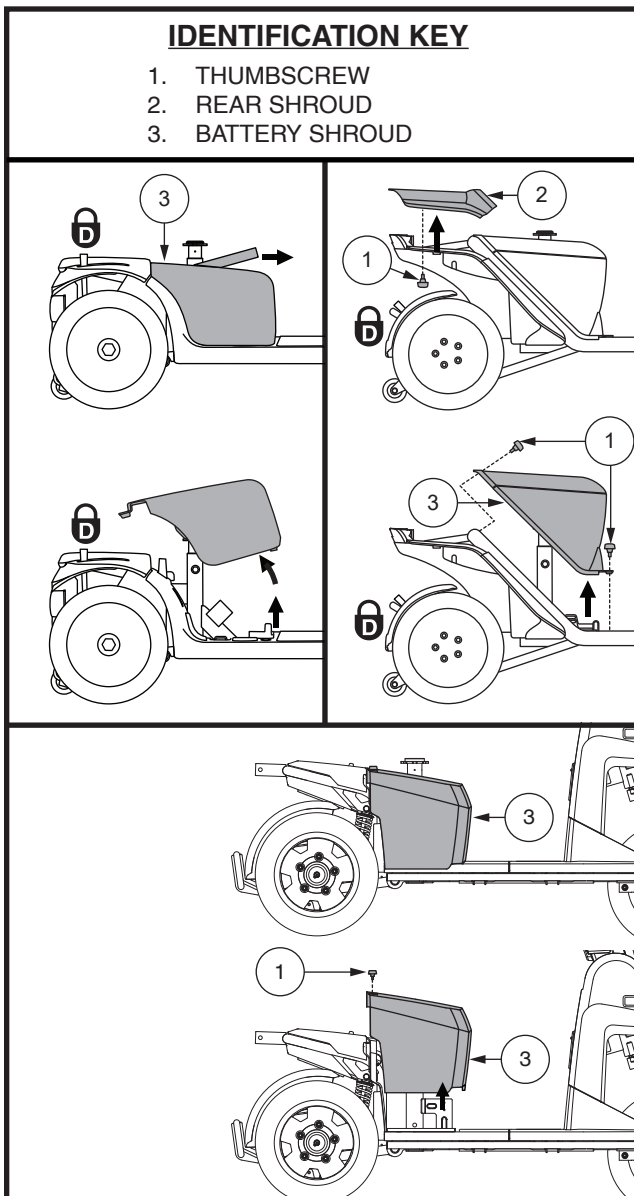

Figure 15. Battery Shroud Removal/Installation

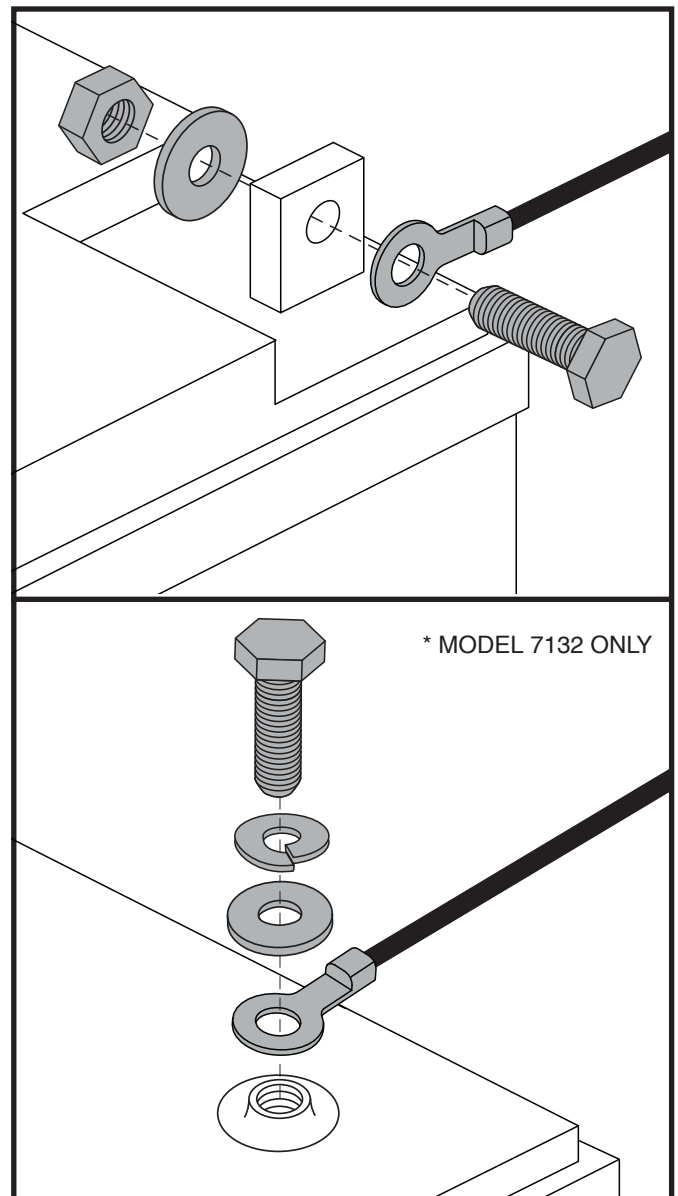

Figure 16. Battery Terminal Hardware

# III. BATTERIES AND CHARGING

## IDENTIFICATION KEY

- |                         |                                    |
|-------------------------|------------------------------------|
| 1. MAIN CIRCUIT BREAKER | 2. BATTERY TERMINALS UNDER BOOTS   |
| 1a. Reset Button        | 3. BATTERY TIE-DOWN STRAP          |
| 1b. Reset Lever         | 4. BATTERY HARNESS CONNECTORS      |
| 1c. Auto Reset style    | 5. FRONT-TO-REAR HARNESS CONNECTOR |
|                         | 6. BATTERY JUMPER HANRESS          |

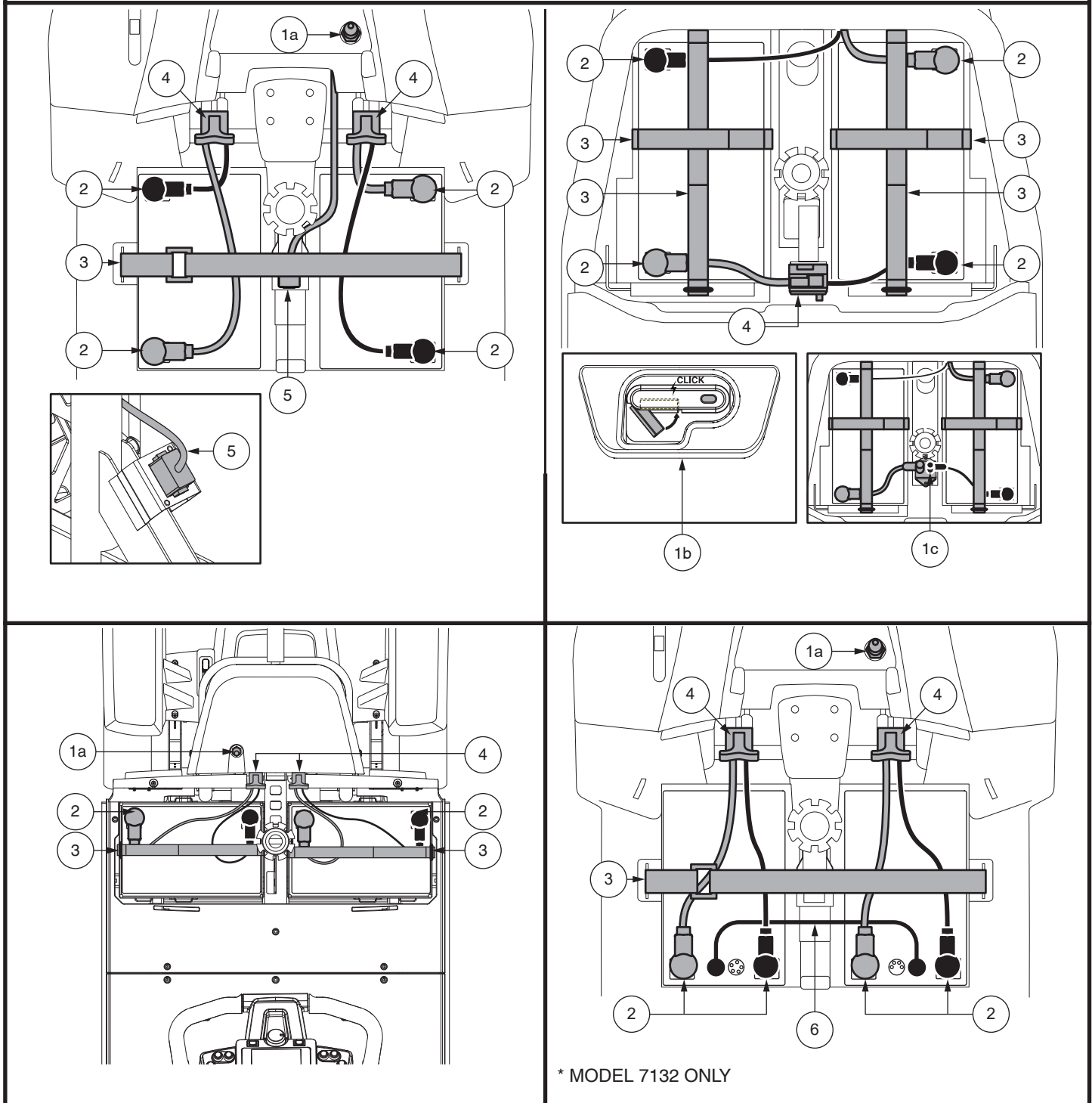

Figure 17. Battery Removal/Installation Terminals and Connections

## Battery Securement and Strap Routing

1. Secure the batteries in the battery wells by routing the provided battery straps through the battery well slots as shown.
2. Ensure the short strap runs over the top of the long strap.

**NOTE:** Before securing both straps, ensure the D-ring is positioned as shown here. The D-ring should be positioned within 1 inch (2.54 cm) of, but never touch, the battery well.

3. Any excess strapping should be placed facing the back, or next to the seat post, of the scooter.



**WARNING!** The battery straps should never be positioned under the battery.

### IDENTIFICATION KEY

- |                      |                    |
|----------------------|--------------------|
| 1. REUSABLE FASTENER | 5. FRONT SLOT      |
| 2. SHORT STRAP       | 6. SIDE SLOT       |
| 3. LONG STRAP        | 7. REAR SLOT       |
| 4. D-RING            | 8. BATTERY SPACERS |

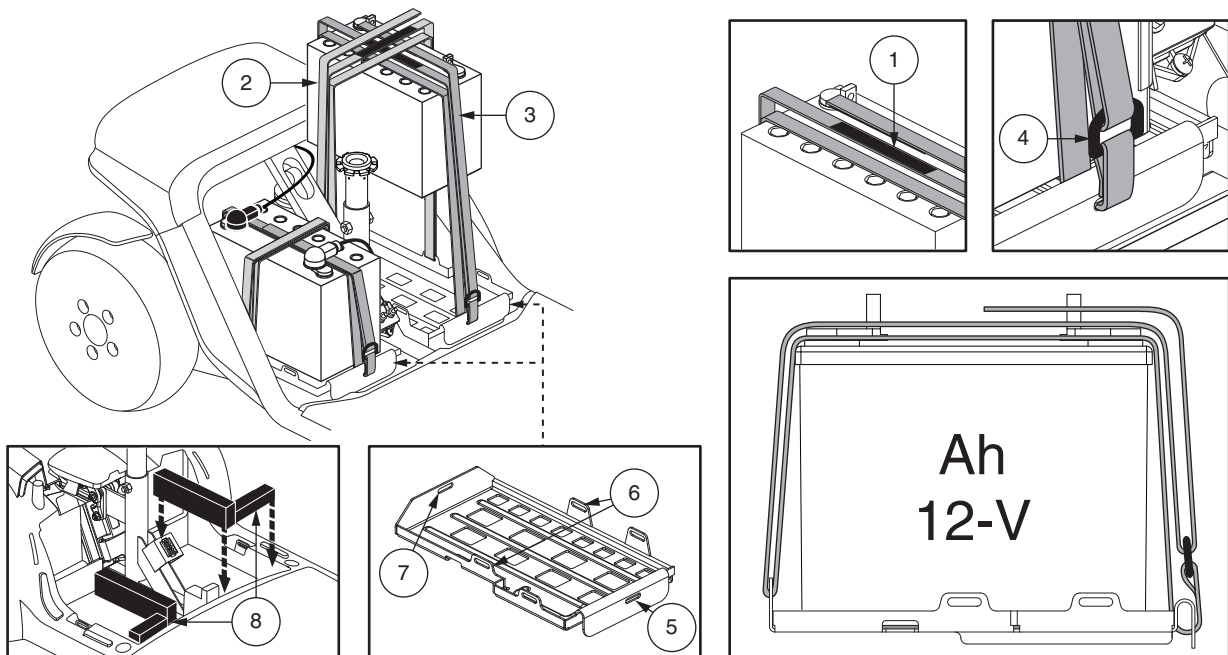

Figure 18. Battery Securement for Models 614 and 714

In the event of an electrical issue or a thermal event, the battery power can be quickly disconnected so that the batteries can be isolated for transport for service (**model 7132 only**).



**WARNING!** When faced with an emergency situation, the batteries can be quickly disconnected by pulling **FORWARD** on the emergency battery disconnect strap. Use caution. Be advised that turning off power to the scooter may cause the scooter to stop abruptly. To release the emergency stop and restore driving capability to the scooter, remove the seat and battery shroud, and reconnect the battery connector as shown in Figure 16.

**WARNING!** If the battery disconnect strap is engaged while your scooter is in motion, the electronic brakes will engage and your scooter will come to an abrupt stop.

# IV. OPERATION

## BEFORE GETTING ONTO YOUR SCOOTER

- Have you fully charged the batteries? See III. “Batteries and Charging.”
- Is the manual freewheel lever in the drive (rearward) position? Never leave the manual freewheel lever pushed forward unless you are manually pushing your scooter.
- Ensure the air temperature is between -13°F/-25°C to 122°F/50°C.

## GETTING ONTO YOUR SCOOTER

1. Make certain that the key is removed from the key switch.



**WARNING! Never attempt to get onto or off of your scooter without first removing the key from the key switch. This will prevent the scooter from moving if accidental throttle control lever contact is made.**

2. Stand at the side of your scooter.
3. Disengage the seat rotation lever and rotate the seat until it is facing you.
4. Make certain that the seat is fixed securely in position.
5. Position yourself comfortably and securely in the seat.
6. Disengage the seat rotation lever and rotate the seat until you are facing forward.
7. Make certain that the seat is fixed securely in position.
8. Make certain that your feet are safely on the floorboard.

## PRE-RIDE ADJUSTMENTS AND CHECKS

- Is the seat at the proper height? See V. “Comfort Adjustments.”
- Is the seat fixed securely in position?
- Is the tiller at a comfortable setting and locked securely in place? See V. “Comfort Adjustments.”
- Is the key fully inserted into the key switch and turned clockwise to the “on” position?
- Does the horn work properly?
- Is your proposed path clear of people, pets, and obstacles?
- Have you planned your route to avoid adverse terrain and as many inclines as possible?
- Prior to riding your scooter, especially after storage, squeeze the handbrake lever fully five to seven (5-7) times to confirm proper function of the handbrake.

## OPERATING YOUR SCOOTER

**WARNING! The following can adversely affect steering and stability while operating your scooter, resulting in loss of control, tipping, and/or personal injury:**

- Holding onto or attaching a leash to walk your pet.
- Carrying passengers (including pets).
- Hanging any article from the tiller.
- Towing or being pushed by another motorized vehicle.



**WARNING! Tipping Risk! Avoid abrupt maneuvers at excessive speed. It is recommended that you set the speed adjustment dial to the lowest setting until you become familiar with scooter controls and operation.**

**WARNING! Scooter braking distances are greater on an incline than on the horizontal.**

**WARNING! Keep both hands on the tiller and your feet on the floorboard at all times while operating your scooter. This driving position gives you the most control over your vehicle.**

- Set the speed adjustment dial to your desired speed.
- Press your thumb against the appropriate side of the throttle control lever.
- The electromechanical disc park brake automatically disengages and the scooter accelerates smoothly to the speed you preselected with the speed adjustment dial.
- Pull on the left handgrip to steer your scooter to the left.
- Pull on the right handgrip to steer your scooter to the right.

## IV. OPERATION

- Move the tiller to the center position to drive straight ahead.
- To stop, slowly release the throttle control lever. The electronic brakes will automatically engage, bringing your scooter to a stop.

**NOTE:** *Your scooter's reverse speed is slower than that of the forward speed you preset with the speed adjustment dial or on the LCD control panel.*

### GETTING OFF OF YOUR SCOOTER

1. Bring your scooter to a complete stop.
2. Power down your scooter and remove the key from the key switch.



**WARNING!** Never attempt to get onto or off of your scooter without first removing the key from the key switch. This will prevent the scooter from moving if accidental throttle control lever contact is made.

3. Disengage the seat rotation lever and rotate the seat until you are facing toward the side of your scooter.
4. Make certain that the seat is fixed securely in position.
5. Carefully and safely get out of the seat and stand to the side of your scooter.
6. You can leave the seat facing to the side to facilitate boarding your scooter next time.

### POWER DOWN TIMER FEATURE

Your scooter is equipped with an automatic power down timer feature designed to prevent your Scooter from moving if left unattended. If you mistakenly leave the key in the “on” position but do not use your scooter for approximately 20 minutes, the scooter's controller shuts down automatically. Although the controller is shut down, power will still be supplied to the scooter's electrical system.

If the power down timer feature takes effect, perform the following steps to resume normal operation:

1. Remove the key from the key switch.
2. Reinsert the key and power up your scooter.

# V. COMFORT ADJUSTMENTS

## TILLER ANGLE ADJUSTMENT (See figure 1, 8 or 19)

**WARNING!** Remove the key from the key switch before adjusting the tiller or the seat. Never attempt to adjust the tiller or the seat while the scooter is in motion.



**WARNING!** Prior to operating the scooter, push and pull on the tiller to ensure that the angle adjustment mechanism is secure. Inspect the tiller adjustment knob and the angle adjustment mechanism to ensure that they are fully engaged. If there is movement in the tiller, check to make sure that the tiller adjustment knob is fully tightened.



**WARNING!** Do not attempt to use the tiller adjustment lever as a handbrake.

**NOTE:** In order to fully lower the tiller for purposes of disassembly or transport, you must first completely remove the seat.

## MIRROR POSITION

To install the mirror (see figure 1 or 8):

1. Determine on which side to install the mirror and remove the rubber plug from the top of the tiller handle.
2. Insert the threaded end of the mirror holder into the opening and rotate it clockwise until snug.
3. If necessary, rotate the nut clockwise to secure the mirror in place.

To adjust the mirror:

1. Position yourself in a seated driving position facing forward.
2. Adjust the mirror left, right, up, or down until you have a good line of sight behind you.

## SEATBACK ADJUSTMENT



**WARNING!** Do not operate your scooter with the seatback in a reclined position.

**WARNING!** Always keep your back pressed firmly against the seatback while adjusting the angle.

To adjust your scooter's reclining seat, you can adjust the seatback angle with the seatback adjustment lever. See figure 20.

1. With your back pressed up against the seatback, lift up on the seatback adjustment lever and lean forward or rearward to adjust the seatback angle.
2. Release the seatback adjustment lever once the seat is in a comfortable riding position.

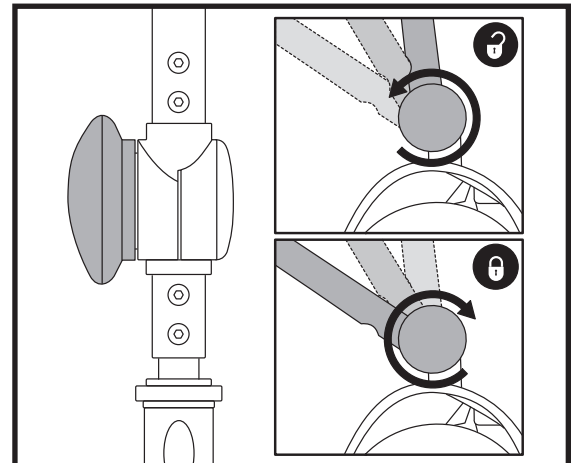

Figure 19. Tiller Adjustment Knob

## IDENTIFICATION KEY

1. SEATBACK ADJUSTMENT LEVER
2. SEAT ROTATION LEVER
3. ARMREST ANGLE ADJUSTMENT DIAL
4. SEAT SLIDING LEVER
5. ACCESSORY BRACKET
6. DETENT PIN

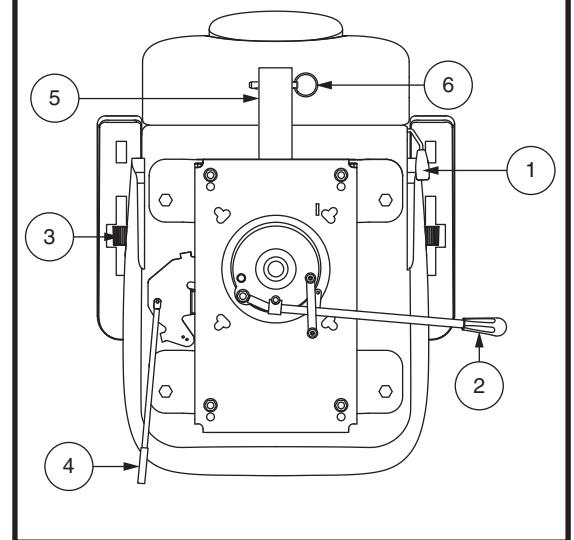

Figure 20. Seat Adjustments

# V. COMFORT ADJUSTMENTS

## SEAT ROTATION ADJUSTMENT

The seat rotation lever will secure the seat into several positions.

1. Pull upward on the seat rotation lever to disengage the seat. **See figure 20.**
2. Rotate the seat to the desired position.
3. Release the lever to secure the seat into place.

## ARMREST ANGLE ADJUSTMENT

Armrest angle of your scooter can be adjusted upward or downward by turning the adjustment dial. **See figure 20.**

**NOTE:** The armrests also pivot upward to make getting on and off of your scooter easier.

## FRONT-TO-BACK SEAT ADJUSTMENT

You can reposition the seat forward or rearward to adjust the distance between the seat and the tiller.

1. Move the seat sliding lever located at the lower left side of the seat outward. **See figure 20.**
2. While holding the lever out, slide the seat forward or rearward.
3. Release the seat sliding lever once the seat is in the desired position.

## ACCESSORY BRACKET

The rear-mounted accessory bracket allows you to attach a personal accessory such as a basket, walker holder, or oxygen tank to the back of your scooter. Utilize the detent pin to securely mount your item to the accessory bracket. **See figure 20.** See your authorized Provider for details.

## SEAT HEIGHT ADJUSTMENT

The seat can be repositioned to several different heights. **See figure 21.**

1. Remove the seat and rear shrouds from your scooter.
2. Remove the seat height adjustment bolt.
3. Raise or lower the upper seat post to the desired seat height.
4. While holding the upper seat post at that height, align the adjustment holes of the upper and lower seat posts.
5. Insert the seat height adjustment bolt through the locating holes of both the upper and lower seat posts.
6. Reinstall the nut onto the seat height adjustment bolt and tighten.
7. Reinstall the rear shrouds and the seat.

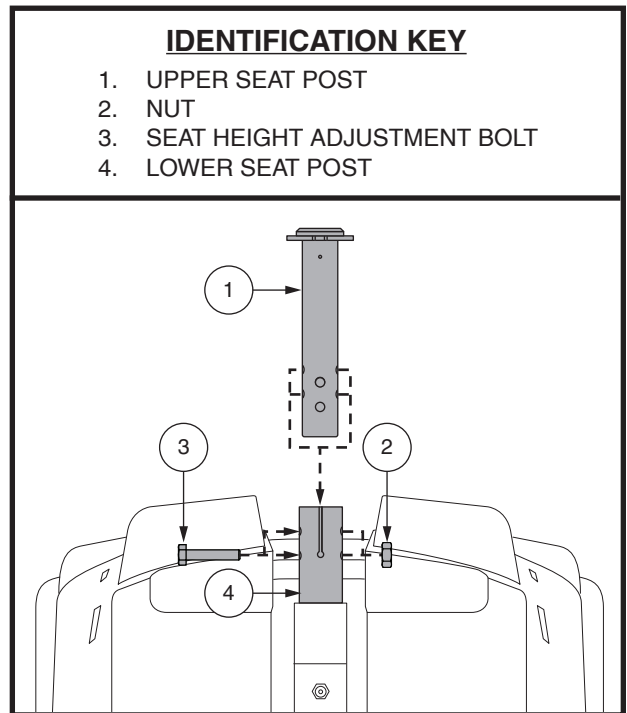

Figure 21. Seat Height Adjustment

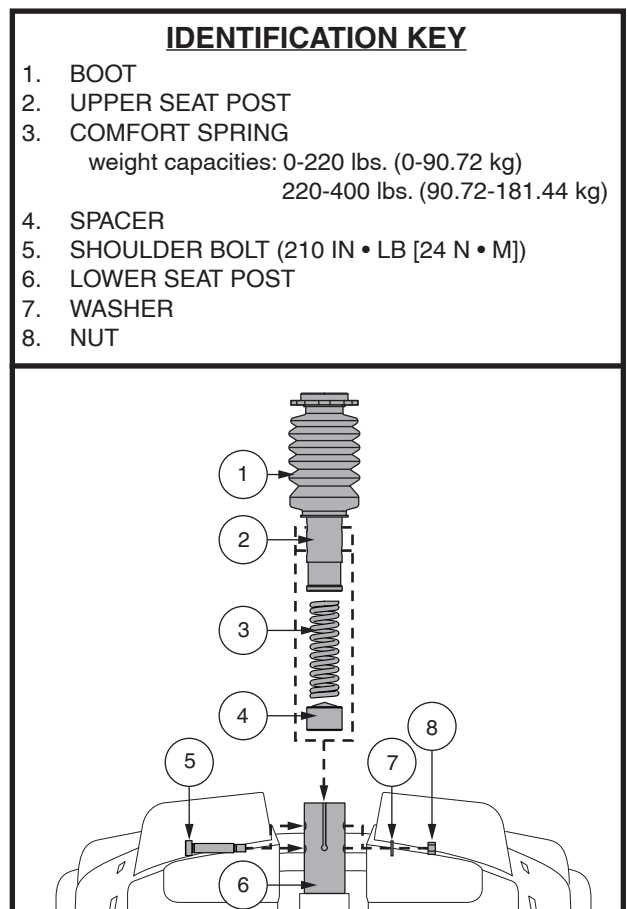

Figure 22. Seat Height Adjustment - Comfort Seat Post

# V. COMFORT ADJUSTMENTS

## SEAT HEIGHT ADJUSTMENT—COMFORT SEAT POST (IF EQUIPPED)

To reposition the seat to one of two different heights:

1. Remove the seat from your scooter. Pull upward and hold the seat rotation lever to disengage the seat, then rotate the seat and lift it off of the scooter.
2. Remove the rear shroud.
3. Push up the seat post boot to uncover the hardware.
4. Push down on the seat post while loosening and removing the shoulder bolt, washer, and nut. **See figure 22.**
5. Remove the comfort spring.
6. To raise the seat to the top most mounting hole, insert the height adjustment spacer. To lower the seat to the lowest mounting hole, remove the height adjustment spacer.
7. Reinstall the comfort spring.
8. Hold the upper seat post at the desired height and match up the locating holes in the lower seat post. Utilize the top holes for the upper position or the bottom holes for the lower position.

**NOTE:** When the seat post is mounted in the upper position, you must utilize two spacers.

9. Press down on the seat post while reinstalling the hardware and tightening to 210 in • lb (24 N • m).
10. Replace the rear shroud and the seat.

## SEAT SUSPENSION ADJUSTMENT (IF AVAILABLE)

You can loosen or stiffen the seat suspension based on which comfort spring you install.

To adjust the seat suspension:

1. Remove the seat from your scooter. Pull upward and hold the seat rotation lever to disengage the seat, then rotate the seat and lift it off of the scooter.
2. Remove the rear shroud.
3. Push up the seat post boot to uncover the hardware.
4. Push down on the seat post while loosening and removing the hex head bolt and nut.
5. Remove the current spring.
6. Install the desired spring. **See figure 22.**
7. Press down on the seat post while reinstalling the hardware and tightening to 210 in • lb (24 N • m).
8. Replace the rear shroud and the seat.

## POSITIONING BELT (OPTIONAL)

Your scooter seat may be equipped with an auto-type positioning belt that can be adjusted for operator comfort. The positioning belt is designed to help support the operator so that he or she does not slide down or forward in the seat. The positioning belt is not designed for use as a restraining device.



**WARNING!** The positioning belt is not designed for use as a seat belt in a motor vehicle. Nor is your scooter suitable for use as a seat in any vehicle. Anyone traveling in a vehicle should be properly belted into seats approved by the vehicle manufacturer.

**WARNING!** The positioning belt should be secured at all times. Never allow the positioning belt to hang or drag on the floor as it may become entangled.

# V. COMFORT ADJUSTMENTS

## To install the positioning belt (if required):

1. Remove the seat from your scooter.
2. Place the seat upside down so that you can see the bottom of the seat base. See figure 23.
3. Use a wrench to remove the two rear bolts on the outermost part of the seat frame.
4. Insert the bolt through the appropriate ends of the positioning belt and then reinstall the bolts back into the seat frame.
5. Tighten the bolts.

## Metal tab style positioning belt

### To adjust the positioning belt for operator comfort:

1. Insert the metal tab on the right side of the belt into the plastic housing on the opposite strap until you hear a “click.” See figure 24.
2. Pull the strap on the right side of the belt until it is secure, but not so tight as to cause discomfort.

### To release the positioning belt:

1. Press the push button mechanism on the plastic housing.

**MANDATORY! Make sure the positioning belt is properly secured to the scooter and is adjusted for operator comfort before each use.**



**MANDATORY! Inspect the positioning belt for loose parts or damage, including tears, worn spots, bent hardware, or damaged latch mechanisms, dirt or debris, before each use of the scooter. If you discover a problem, contact your authorized Provider for maintenance and repair.**

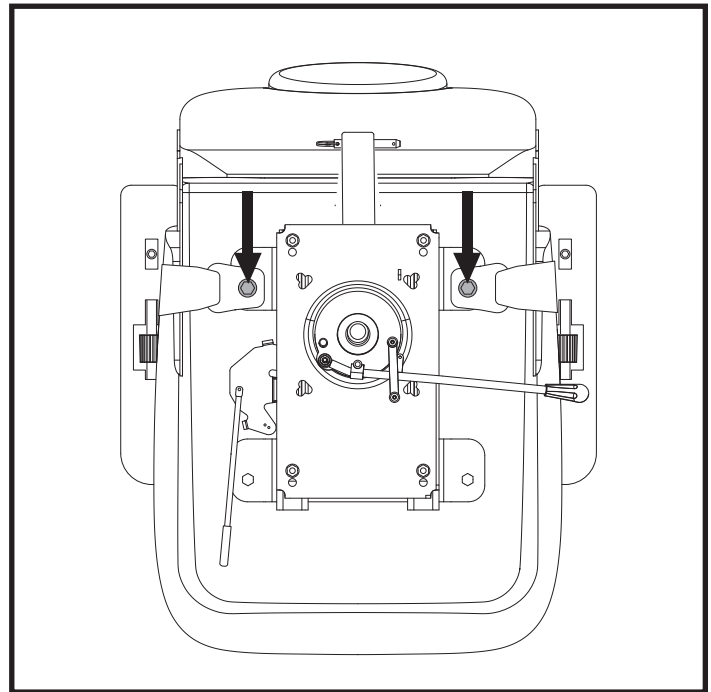

Figure 23. Positioning Belt Bolts

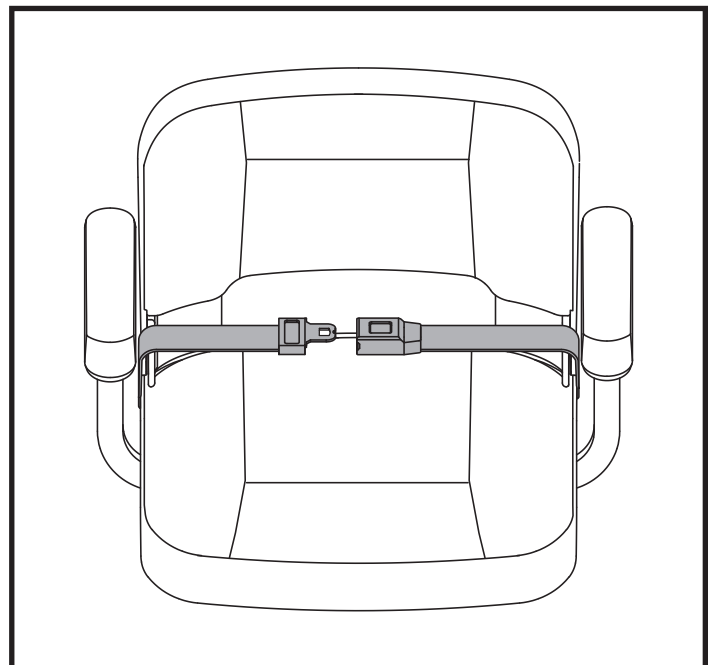

Figure 24. Positioning Belt - Metal Tab Style

## VI. DISASSEMBLY AND ASSEMBLY

**NOTE:** Please check the Scooter Features Table on the inside of the front cover to determine if your scooter model can be disassembled for transporting or storage purposes.

### DISASSEMBLY

You can disassemble the scooter into several pieces: the seat, the rear section, the front section, the batteries, the basket, and the battery shroud. See figure 25. No tools are required to disassemble or assemble your scooter, but keep in mind that the disassembled sections of the scooter take up more floor space than the assembled unit. Always disassemble or assemble your scooter on a level, dry surface with sufficient room for you to work and move around your scooter—about 5 feet (1.5 meters) in all directions. Remember that some scooter components are heavy and you may need assistance when lifting them.



**WARNING!** Do not lift weight beyond your physical capability. Ask for assistance when necessary while disassembling or assembling your Scooter.

**WARNING!** Do not pick up the seat frame or scooter by the armrests. They are free to pivot, and you may lose control of the seat if they do so.

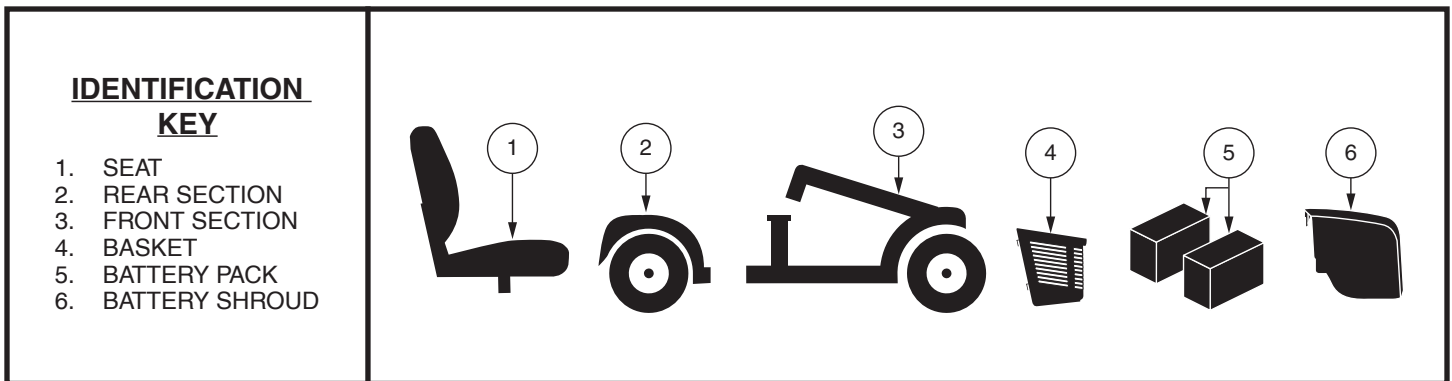

Figure 25. Disassembled Scooter

#### To disassemble your scooter:

1. Remove the seat by lifting it straight up and off of the scooter. If you encounter resistance when removing the seat, disengage the seat rotation lever and swivel the seat back and forth while lifting up on the seat.
2. Gently pull the battery shroud forward, then lift up and off of the scooter.
3. Disconnect the battery tie-down strap.
4. Disconnect the front-to-rear harness.
5. Unplug both battery harnesses by depressing the tabs and then pulling each harness straight up. See figure 17.
6. Remove the batteries from the battery wells.

**NOTE:** If spacers are installed to secure the batteries, remove the spacers for safe keeping until the scooter is reassembled. See figure 18.



**WARNING!** Failure to unplug both battery harnesses and the front-to-rear harness prior to separating the front and rear sections could result in permanent damage to the scooter.

# VI. DISASSEMBLY AND ASSEMBLY

## FRAME SEPARATION

### To separate frame:

1. Arrange the front wheel(s) in a straight forward-facing position.
2. Lower the tiller.

**NOTE:** *The pivoting tiller is equipped with a mechanism that will lock the front wheels in place when the tiller is completely lowered and secured.*

3. Grasp and lift up on the frame release lever. See figure 26.
4. Lift the front section up until the frame hooks of the front section separate from the rear section.
5. Slowly separate the two sections.

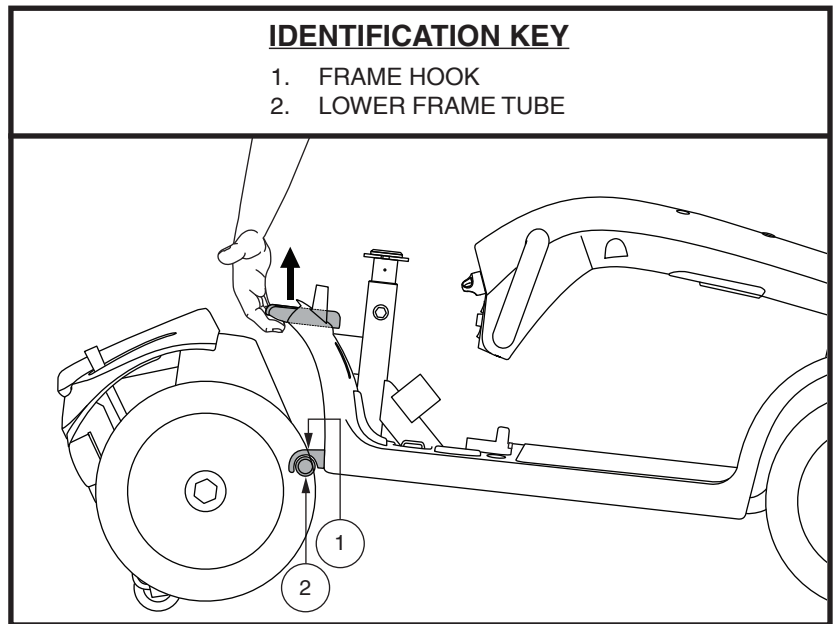

Figure 26. Frame Release Lever

## ASSEMBLY

### To assemble your scooter:

1. Position the front and rear sections of your scooter as shown in figure 26.
2. Use the frame release lever to lift the front section as you align the frame hooks of the front section with the lower frame tube of the rear section.
3. Once the frame hooks are over the lower frame tube, lower the front section and pivot the rear section simultaneously. This will engage the frame lockup automatically.
4. Raise the tiller.
5. Connect the front-to-rear cable.
6. Reinstall the battery spacers if applicable. See figure 18.
7. Reinstall the batteries to the battery wells.
8. Connect both battery harnesses. See figure 17.
9. Secure the battery tie-down strap.
10. Reinstall the battery shroud.
11. Reinstall the seat and rotate it into place.



**WARNING!** After assembly, make absolutely certain the tiller lock knob is in the unlocked position before riding your Scooter.

# VII. BASIC TROUBLESHOOTING

Any electromechanical device occasionally requires some troubleshooting. However, most of the problems that may arise can usually be solved with a bit of thought and common sense. Many of these problems occur because the batteries are not fully charged or because the batteries are worn down and can no longer hold a charge.

## DIAGNOSTIC CODES

The diagnostic codes for your Scooter are designed to help you perform basic troubleshooting quickly and easily. A diagnostic code will sound and/or flash in the event one of the conditions listed below develops. Depending on the model you own, your Scooter will communicate by one of the coding methods as follows:

1. A diagnostic code will begin, depending on model, with a series of fast beeps and/or flashes directly followed by slower beeps and/or flashes which indicates the actual code. The code is only beeped and/or blinked once. To repeat the diagnostic code, remove the key, then reinsert it and turn it to the “on” position, **OR**
2. A diagnostic code will identify the condition, pause, then repeat the code. The diagnostic code will continue to alert you in this manner until the scooter is turned off.

**NOTE: Your scooter will not run unless the code condition is resolved and the scooter has been turned off, then turned back on.**

FAULT CODE	CONDITION	SOLUTION
■ (1)	Battery charge is low.	Charge batteries as soon as possible.
■■ (2)	Battery charge is too low.	Charge batteries.
■■■ (3)	The scooter’s battery voltage is too high to operate the scooter, or the charger is still connected to the off-board charger port.	Unplug charger and/or turn key off, then back on again.
■■■■ (4)	Current limit time out.	Turn the scooter off for a few minutes, then turn your scooter back on.
■■■■■ (5)	The manual freewheel lever is in the (forward) freewheel position.	Remove the key from the key switch, then push the manual freewheel lever to the drive (rearward) position and restart your scooter.
■■■■■■ (6)	Throttle control lever not at center position at start-up.	Verify that the batteries are fully charged. If the batteries are fully charged, then return the throttle control lever to center position, turn scooter off then back on.
■■■■■■■ (7)	Speed pot error.	Contact your authorized Provider for assistance.
■■■■■■■■ (8)	Motor volts error.	Contact your authorized Provider for assistance.
■■■■■■■■■ (9)	Other internal errors.	Contact your authorized Provider for assistance.

Figure 27. Models with Tiller Console

### What if all the systems on my scooter seem to be dead?

- Make certain that the key is in the “on” position.
- Check that the batteries are fully charged.
- Push in the main circuit breaker reset button. See II. “Your Scooter.”
- Make certain that both battery harnesses and the front-to-rear harness are firmly connected.
- Be sure the power down timer feature has not been activated. See IV. “Operation.”

# VII. BASIC TROUBLESHOOTING

FAULT CODE	CONDITION	SOLUTION	ERROR MESSAGE
1	Batteries need charging	Charge batteries as soon as possible.	N/A
2	Low voltage; batteries need charge immediately	Charge batteries as soon as possible.	LO BAT
3	Over voltage	Unplug charger and/or turn scooter off, then back on.	HI BAT
4	Over current	Turn scooter off for a few minutes, then turn scooter back on.	HI CUR
5	Park brake fault	Remove the key from the key switch, then push the manual freewheel lever to the drive (rearward) position and restart your scooter.	BRAKE
6	Throttle control lever not centered at start-up	Return the throttle control lever to center position, turn scooter off, then back on.	T POT
7	Throttle control lever broken or faulted	Contact your authorized Provider.	T POT
8	Motor fault	Contact your authorized Provider.	MOTOR
9	Other fault	Contact your authorized Provider.	OTHER

**Figure 28. Model 614 with LCD Control Panel**

**What if my scooter does not move when I engage the throttle control lever?**

- When the manual freewheel lever is pushed forward, the brakes are disengaged and all power to the motor/transaxle assembly is cut.
- Push rearward on the manual freewheel lever, turn the scooter off, and then turn the scooter on to return to normal scooter operation.

**What if the main circuit breaker repeatedly trips?**

- If the main circuit breaker trips repeatedly, see your authorized Provider for service.
- Charge the batteries more frequently. See III. “Batteries and Charging.”
- See III. “Batteries and Charging” or the additional “Product Specifications Sheet” for information about your scooter’s battery type.

**What if the battery condition meter dips way down and the motor surges or hesitates when I engage the throttle control lever?**

- Fully charge your scooter’s batteries. See III. “Batteries and Charging.”

If you experience any problems with your scooter that you are not able to solve, immediately contact your authorized Provider for information, maintenance, and service.

## VIII. CARE AND MAINTENANCE

Your scooter requires a minimal amount of care and maintenance. If you do not feel confident in your ability to perform the maintenance listed below, you may schedule inspection and maintenance at your authorized Provider. The following areas require periodic inspection and/or care and maintenance.

### TIRE PRESSURE

- If equipped with pneumatic tires, always maintain the psi/bar/kPa air pressure rating indicated on each tire.



**WARNING! It is important that the psi/bar/kPa air pressure rating indicated on each tire be maintained in pneumatic tires at all times. Do not underinflate or overinflate your tires. Low pressure may result in loss of control, and overinflated tires may burst. Failure to maintain the psi/bar/kPa air pressure rating indicated on the tires at all times may result in tire and/or wheel failure.**

- Regularly inspect your scooter's tires for signs of damage or wear.

### EXTERIOR SURFACES

Bumpers, tires, and trim can benefit from an occasional application of a rubber or vinyl conditioner.



**WARNING! Do not use a rubber or vinyl conditioner on the scooter's vinyl seat or tire tread, as this may cause them to become dangerously slippery.**

### CLEANING AND DISINFECTION

Precautions must be taken when cleaning equipment/devices to lower the risk of spreading infection. This is to limit the spread of illness and other potentially infection material (OPIM) (blood components).

- Use a damp cloth and mild, non-abrasive cleanser to clean the plastic and metal parts of your scooter. Avoid using products that may scratch the surface of your scooter.
- If necessary, clean your product with an approved disinfectant. Make sure the disinfectant is safe for use on your product before application.

### HOW TO CLEAN/DISINFECT EQUIPMENT:

**HARD/SOFT SURFACES** (Plastic shrouds, metal framing, seat fabric, tires, armrests and footplate mats, as applicable)

- For hard/soft surfaces, remove visible contamination if present.
  - For plastic and metal use Lysol®/Clorox® disinfecting spray/wipes and other qualified SARS-CoV-2 disinfecting products.
  - For other vinyl surfaces, clean with vinyl safe disinfecting wipes or solutions.
    - Suggested Disinfectants
      - Birex® SE Disinfectant, Bleach-Rite® Disinfecting Spray, Citrace® Germicide
      - Dispatch® Spray Hospital Cleaner Disinfectant with Bleach
      - Diluted Bleach Solution (10% dilution or less); Note: Bleach with pH factor between 7 and 9 is suitable; a product with a pH of 10.5 or higher may damage the vinyl surface integrity over an extended period of time.
    - Disinfecting Wipes
      - Clorox, Green Works, PDI Sani-Cloth HB Wipes
      - Lysol, Oxivir, Virox, and CaviWipes.
  - For Tire cleaning, clean with off the shelf tire/wheel cleaners

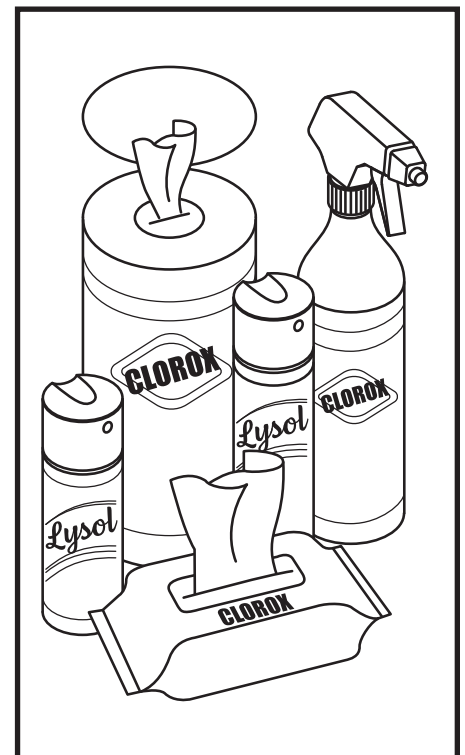

## VIII. CARE AND MAINTENANCE

**ELECTRONICS** (Joystick controller, enhanced displays, touch screens, remote controls, keyboards, cell phones and tablets, as applicable)

- For electronics, remove visible contamination if present.
  - Turn off device and disconnect batteries.
  - Never spray any liquids directly into the product(s).
  - Moisten a microfiber cloth with a mixture of 70% isopropyl alcohol/30% water solution. The cloth should be damp, but not dripping or excessively wet. Dry surfaces thoroughly to avoid pooling of liquids and prior to boxing.

**WARNING!** Follow all safety instructions for the proper use of the disinfectant and/or cleaning agent before applying it to your product. Failure to comply may result in skin irritation or premature deterioration of upholstery and/or power chair finishes.



**WARNING!** Never use any cleaning or disinfecting agent, solvent, lubricant, or any other product on the brake pads, brake discs, transaxle, motor/gearbox of your mobility product. Doing so may damage the components and/or cause them not to function properly. Property injury and/or personal injury may result.

**WARNING!** Never hose off your power chair or place it in direct contact with water. Your power chair has a painted, ABS plastic body shroud that allows it to be easily wiped clean with a damp cloth.

**WARNING!** Never use any chemicals to clean a vinyl seat, as they may cause the seat to become slippery or dry out and crack. Use soapy water and dry the seat thoroughly.

### BATTERY TERMINAL CONNECTIONS

- Make certain that the terminal connections remain tight and uncorroded.
- The batteries must sit flat in the battery wells.
- The battery terminals should face away from the seat post.

### WIRING HARNESES

- Regularly check all wiring connections.
- Regularly check all wiring insulation, including the charger power cord, for wear or damage.
- Have your authorized Provider repair or replace any damaged connector, connection, or insulation that you find before using your scooter again.



**PROHIBITED!** Even though the scooter has passed the necessary testing requirements for ingress of liquids, you should keep electrical connections away from sources of dampness, including direct exposure to water or bodily fluids and incontinence. Check electrical components frequently for signs of corrosion and replace as necessary.



**WARNING!** Do not pull on electrical harnesses directly to detach them from the scooter. Always grasp the connector itself when disconnecting the harness to prevent wire damage.

# VIII. CARE AND MAINTENANCE

## WHEEL REPLACEMENT

If your scooter is equipped with pneumatic tires and you have a flat tire, you can have the tube replaced. Contact your authorized Provider for information regarding replacement wheels for your scooter.

**WARNING! Wheels on your scooter should only be serviced/replaced by a qualified technician.**

**WARNING! Be sure that the key is removed from the key switch and the scooter is not in freewheel mode before performing this procedure.**



**WARNING! When changing a pneumatic tire, remove only the lug nuts, then remove the wheel. If any further disassembly is required, deflate the tire COMPLETELY or it may explode.**

Follow these easy steps for a quick and safe repair for pneumatic tires:

1. Remove the key from the key switch and ensure your scooter is not in freewheel mode.
2. Elevate the side of the scooter of which you are removing the tire. Place wooden blocks under the frame to elevate the scooter.
3. If you are replacing the tube, deflate the tire **completely** before taking it off the hub.
4. Remove the lug nuts from the hub. **See figure 29.**
5. Remove the drive wheel from the axle.
6. Remove the screws and separate the rim halves. **See figure 30.**
7. Remove the old tube from the pneumatic tire and replace it with a new tube.
8. Reassemble the rim halves.
9. Slide the wheel back onto the hub.
10. Reinstall the lug nuts and tighten.

**WARNING! Ensure that the axle key is properly installed into the axle slot when mounting the wheel. If not installed securely, the braking system is disengaged which may cause personal injury and/or product damage may result.**



11. Inflate pneumatic tires to the psi/bar/kPa air pressure rating indicated on each tire.
12. Remove the blocks from beneath the scooter.

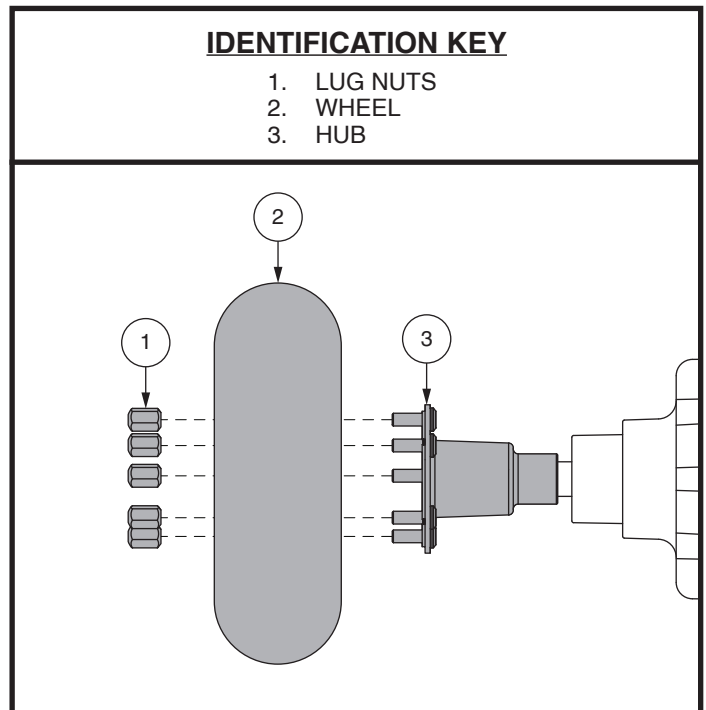

Figure 29. Wheel Replacement

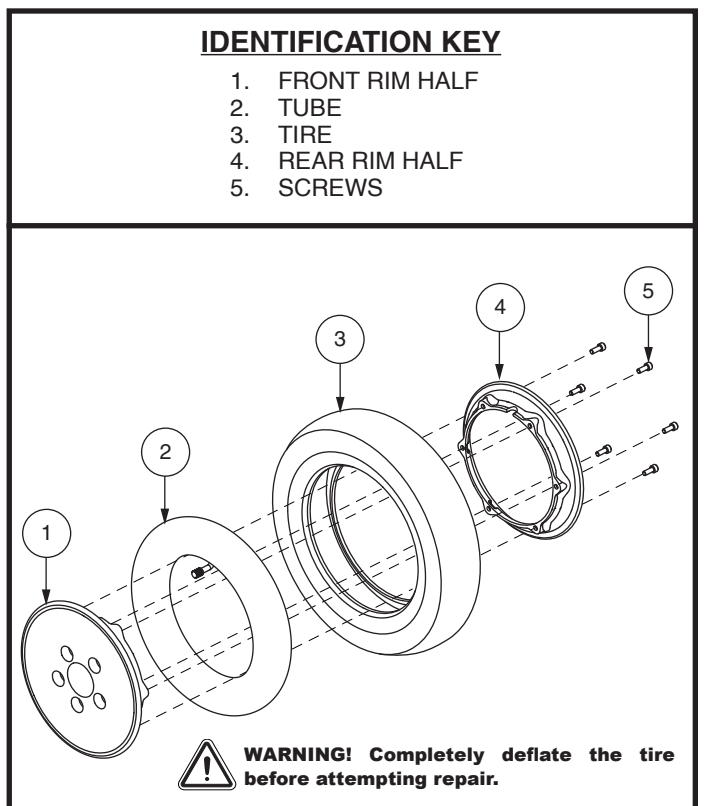

Figure 30. Pneumatic Drive Wheel Disassembly/Assembly

# VIII. CARE AND MAINTENANCE

## DAILY CHECKS

- With the power turned off, check the throttle. Make sure it is not bent or damaged and that it returns to the neutral position when you release it. Do not try to repair it. See your authorized Provider if there is a problem.
- Visually inspect the tiller cable. Make sure that it is not frayed, cut, or has any wires exposed. See your authorized provider if there is a problem.
- Check for flat spots on solid tires. Flat spots could adversely affect stability.
- Inspect the armrests for loose hardware, stress points, or damage. See your authorized Provider if there is a problem.
- Check the brakes. This test should be carried out on a level surface with at least 3 feet (1 meter) of clearance around your scooter.

### To check the brakes:

1. Turn on the power and turn down the speed level of your Scooter.
2. After one second, check the battery condition meter. Make sure that it remains on.
3. Slowly pull the throttle forward until you hear the electric brakes click. Immediately release the throttle. You must be able to hear the electrical brake operating within a few seconds of throttle movement. Repeat this test by pulling the throttle in the opposite direction.

## WEEKLY CHECKS

- Inspect the controller and charger connectors for corrosion. Contact your authorized Provider if necessary.
- Check for proper tire inflation, if equipped with pneumatic tires. If a tire does not hold air, contact your authorized Provider for replacement of the tube.

## MONTHLY CHECKS

- Check that the anti-tip wheels do not rub the ground when you operate the Scooter.
- Check for extreme wear on the anti-tip wheels. Replace them as necessary.
- Check for tire wear. See your authorized Provider for repair.
- Keep you Scooter clean and free of foreign material, such as mud, dirt, hair, food, drink, etc.

## YEARLY CHECKS

Take your Scooter to your authorized Provider for yearly maintenance, especially if you use your Scooter on a daily basis. This helps ensure that your Scooter is functioning properly and helps prevent future complications.

## ABS PLASTIC SHROUDS

If your Scooter has a body shroud with a **glossy finish**, the body shroud has been sprayed with a clear sealant coating. You can apply a light coat of car wax to help it retain its high-gloss appearance. If your Scooter has a body shroud with a **matte finish**, use **ONLY** products developed for matte-finish paint. Do not use wax, detail spray, ArmorAll®, or any product made for glossy paint.



**WARNING! Carefully choose the correct product to protect the finish of your Scooter's shroud(s). ONLY products developed for matte-finish paint should be used on shrouds with a matte finish. Failure to follow this warning may result in damage to the shroud's matte paint finish.**

## AXLE BEARINGS AND THE MOTOR/TRANSAXLE ASSEMBLY

These items are all prelubricated, sealed, and require no subsequent lubrication.

## MOTOR BRUSHES

The motor brushes are housed inside of the motor transaxle/assembly. They should be inspected periodically for wear by your authorized Provider.

## CONSOLE, CHARGER AND REAR ELECTRONICS

- Keep these areas free of moisture.
- Allow these areas to dry thoroughly if they have been exposed to moisture before operating your scooter again.

# VIII. CARE AND MAINTENANCE

## BRAKE PADS

The brake pads on your scooter should be inspected periodically for wear. Once the pads reach 2 mm or 1/16-th of an inch in thickness, they should be replaced. If any of the brake pads needs to be replaced, then it is best to replace all the brake pads at the same time. Contact your authorized Provider for more information on replacing the brake pads.

## FUSE REPLACEMENT

**In the event a fuse should cease to work:**

1. Remove the fuse by pulling it out of its slot.
2. Examine the fuse to be sure it is blown. See figure 31.
3. Insert a new fuse of the same rating.



**WARNING! The replacement fuse must exactly match the rating of the fuse being replaced. Failure to use properly rated fuses may cause damage to the electrical system.**

## NYLON LOCK NUT REPLACEMENT

Any nylon insert lock nut removed during the periodic maintenance, assembly, or disassembly of the scooter must be replaced with a new nut. Nylon insert lock nuts should not be reused as it may cause damage to the nylon insert, resulting in a less secure fit. Replacement nylon insert lock nuts are available at local hardware stores or through your authorized Provider.

## STORING YOUR SCOOTER

If you plan on not using your scooter for an extended period of time, it is best to:

- Fully charge its batteries prior to storage.
- Disconnect the batteries from the scooter.
- Store your scooter in a warm, dry environment.
- Avoid storing your scooter where it will be exposed to temperature extremes.
- Although your scooter can withstand short-term storage temperatures between -40°F (-40°C) to 149°F (65°C), it is recommended that long-term storage temperatures be between -13°F (-25°C) and 122°F (50°C). Ideal storage conditions are 68°F (20°C) to 70°F (21°C) wherever possible, but we realize that is not always feasible due to different climates and environments.



**WARNING! Always protect batteries from freezing temperatures and never charge a frozen battery. Charging a frozen battery can result in damage to the battery.**

Batteries that are regularly and deeply discharged, infrequently charged, stored in extreme temperatures, or stored without a full charge may be permanently damaged, causing unreliable performance and limited service life. It is recommended that you charge the scooter batteries periodically throughout periods of prolonged storage to ensure proper performance.

You may wish to place several boards under the frame of your scooter to raise it off of the ground during periods of prolonged storage. This takes the weight off the tires and reduces the possibility of flat spots developing on the areas of the tires contacting the ground.

## DISPOSAL OF YOUR SCOOTER

Your scooter must be disposed of according to applicable local and national statutory regulations. Contact your local waste disposal agency or authorized Provider for information on proper disposal of packaging, metal frame components, plastic components, electronics, batteries, neoprene, silicone, and polyurethane materials.



**WARNING! Plastic bags are a suffocation hazard. Dispose of plastic bags properly and do not allow children to play with them.**

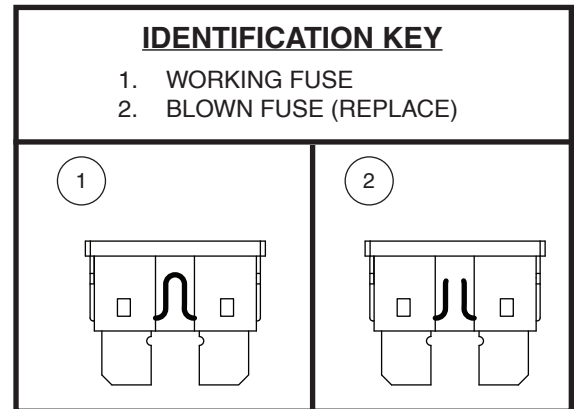

Figure 31. Fuse Replacement



# rehabhire & sales

1 300 000 030

320 Lorimer Street Port Melbourne  
contact@rehabhire.com.au  
rehabhire.com.au

# rehabhire & sales **REPAIRS AND SERVICE**

REGULAR MAINTENANCE OR REPAIRS

1 300 000 030

Unit 6 | 52 Wirraway Drive Port Melbourne  
service@rehabhire.com.au  
rehabhire.com.au/repairs-and-service

# rehabinstallation

CAN MODIFY EVERY ROOM IN YOUR HOME TO  
ENSURE IT IS ACCESSIBLE, SAFE, AND COMFORTABLE

1 300 000 030

320 Lorimer Street Port Melbourne  
contact@rehabinstallation.com.au  
rehabinstallation.com.au



Registered NDIS Provider