

INSTRUCTIONS FOR USE

# Tenor



## **WARNING**

**To avoid injury, always read this Instructions for Use and accompanied documents before using the product.**

Design Policy and Copyright

® and ™ are trademarks belonging to the Arjo group of companies.

© Arjo 2025.

As our policy is one of continuous improvement, we reserve the right to modify designs without prior notice. The content of this publication may not be copied either whole or in part without the consent of Arjo.

## Content

<b>Pre-sale</b> .....	<b>4</b>
<b>Intended Use</b> .....	<b>5</b>
<b>Safety instructions</b> .....	<b>6</b>
Read Before Use .....	6
Serious Incident.....	6
Operational Life .....	6
Bariatric Slings Guidance .....	7
<b>Product description</b> .....	<b>8</b>
Parts referred to in this manual .....	8
Controls and functions .....	9
Control Handset .....	9
Dual control switch .....	9
Emergency Stop Button (red) .....	9
Power on / Reset button (green) .....	9
Power off button (red) .....	9
Automatic cut out .....	9
System failure lower override .....	9
Automatic stop function .....	10
Battery discharge indicator .....	10
Powered adjustable width chassis legs .....	10
Scale (optional) .....	10
<b>Using your Tenor</b> .....	<b>11</b>
Checklist before use .....	11
Preparation .....	11
Before approaching the resident .....	11
To lift a resident from a chair .....	11
To return resident back to a chair .....	12
To lift a resident from a bed .....	13
To lift a resident from the floor .....	15
<b>Battery charging</b> .....	<b>16</b>
<b>Care of your TENOR</b> .....	<b>18</b>
Servicing Advice .....	18
Slings .....	19
Environmental Advice .....	19
<b>Labels</b> .....	<b>20</b>
Key to labels .....	20
Symbol explanation .....	21
<b>Technical specification</b> .....	<b>22</b>
Component Weights .....	22
Maximum Lifting Capacities (Safe Working Load - SWL) .....	22
Electrical .....	22
Environment .....	22
Maximum sound power level .....	23
Hoist Dimensions .....	23
<b>Troubleshooting / Problem Solving</b> .....	<b>25</b>
<b>Preventive Maintenance Schedule</b> .....	<b>27</b>
Arjo Slings .....	27
Arjo Battery Charger .....	27
Arjo Tenor .....	27
Checks to be performed by qualified Arjo personnel .....	28
<b>Electromagnetic Compatibility (EMC)</b> .....	<b>29</b>

# Pre-sale

Intended use, the intended user group and the intended environment; including any contraindications	See "Intended Use" on page 5
Expected lifetime of the product	See "Intended Use" on page 5
Maximum user mass: Minimum user mass: Maximum load:	320 kg (705 lb) N/A 320 kg (705 lb)
Operating forces of controls:	2.5 N
Accessories:	See "Bariatric Slings Guidance" on page 7
Detachable parts:	For <i>Slings</i> , see "Bariatric Slings Guidance" on page 7 For <i>Battery</i> , see "Battery charging" on page 16 For <i>Hand control</i> , see "Controls and functions" on page 9
Compatible products	See "Bariatric Slings Guidance" on page 7
The A-weighted sound power level	62 dB (A)
Name and address of the manufacturer	See back page
<b>Dimensions</b>	
Product Weight (max)	70 kg (155 lb)
Detachable parts above 10 kg	None
Turning circle:	See "Hoist Dimensions" on page 23
Overall	See "Hoist Dimensions" on page 23

# Intended Use

The Tenor is a mobile passive hoist. It is intended for lifting, transfers and short transports of adult residents/patients on horizontal floors in hospitals or long-term care facilities. Transfers with Tenor are made indoors in the patient's room, in communal areas or in a bathroom.

This equipment shall always be handled by a trained caregiver and in accordance with the instructions outlined in the Operating and Product care instructions.

Tenor is intended for bariatric residents/patients with its Safe Working Load of 320kg.

Tenor should only be used for the purpose specified in this Instructions for Use. Any other use is prohibited.

## **PATIENT/RESIDENT ASSESSMENT**

The Tenor mobile lift creates an integrated lifting system for safer, gentler, more dignified handling matched to individual bariatric resident's/patient's needs. It is intended for the resident/patient who has been clinically assessed to correspond with the following categories:

Category D:

- Sits in wheelchair
- Has no capacity to support herself at all
- Cannot stand unsupported and is not able to bear weight, not even partially
- Is dependent on caregiver in most situations

Category E:

- Is a passive patient/resident
- Might be almost completely bedridden
- Is often stiff and has contracted joints
- Is totally dependent

The Tenor is intended to be used for supporting Doris & Emma (refer to mobility gallery below).



If the resident/patient does not meet these criteria an alternative equipment/system shall be used.

Before attempting to raise a resident/patient, a full clinical assessment of the resident's condition and suitability must be carried out by a qualified person on the individual resident/patient to determine if it is advisable that he/she will be lifted and/or transferred using a Tenor.

## **INSTALLATION REQUIREMENTS**

The installation process might be done by a potential operator, subject to them completely understanding the manual before using the Tenor..

## **EXPECTED SERVICE LIFE**

The expected service life of Tenor is ten (10) years, subject to preventive maintenance being carried out in accordance with the instructions for care and maintenance found in the Instructions for Use.

The operational life of the sling and of the consumable parts e.g. batteries, slings etc. is dependent on usage.

The equipment will not be suitable for use if it is damaged.

# Safety instructions



## READ BEFORE USE

Before using your *Tenor*, familiarise yourself with the various parts and controls as illustrated in this document. Read this whole manual thoroughly before operating your *Tenor* in order to prevent injury or damage to the product.

This IFU applies to both equipment with scale and without scale.

Symbols and definitions used in this manual:



### CAUTION

Failure to follow these instructions may cause damage to the product.



### WARNING

Failure to follow these instructions may result in injury to yourself or to others.

## SERIOUS INCIDENT

If a serious incident occurs in relation to this medical device, affecting the user, or the patient then the user or patient should report the serious incident to the medical device manufacturer or the distributor. In the European Union, the user should also report the serious incident to the Competent Authority in the member state where they are located.

## SAFETY INFORMATION



### WARNING

When using the *Tenor*, only use the slings as described in the list on the next page.



### WARNING

Do not overload the *Tenor* beyond the approved maximum lifting capacity (Safe Working Load) of 320 kg (705 lbs).



### CAUTION

Although manufactured to a high standard, the *Tenor* and accessories should not be left for extended periods in humid or wet areas.

Do not, under any circumstances, spray the *Tenor* or accessories (excluding sling) with water e.g. under the shower.



### WARNING

Before attempting to raise a resident, a full clinical assessment of the resident's condition and suitability must be carried out by a qualified person on the individual resident to determine if it is advisable that he/she will be lifted and/or transferred using a *Tenor*.

# Safety instructions

## **BARIATRIC SLINGS GUIDANCE**

Part number	Sling Size	Edge binding colour	Safe Working Load
MAA8000-M	M	Yellow	454 kg/1 000 lb
MAA8000-L	L	Green	454 kg/1 000 lb
MAA8000-XL	XL	Blue	454 kg/1 000 lb
MAA8000-XXL	XXL	Terracotta	454 kg/1 000 lb
MAA8010-M	M	Yellow	454 kg/1 000 lb
MAA8010-L	L	Green	454 kg/1 000 lb
MAA8010-XL	XL	Blue	454 kg/1 000 lb
MAA8010-XXL	XXL	Terracotta	454 kg/1 000 lb
MAA8020-M	M	Yellow	454 kg/1 000 lb
MAA8020-L	L	Green	454 kg/1 000 lb
MAA8020-XL	XL	Blue	454 kg/1 000 lb
MAA8020-XXL	XXL	Terracotta	454 kg/1 000 lb
MAA8030-M	M	Yellow	454 kg/1 000 lb
MAA8030-L	L	Green	454 kg/1 000 lb
MAA8030-XL	XL	Blue	454 kg/1 000 lb
MAA8030-XXL	XXL	Terracotta	454 kg/1 000 lb

If the resident's weight falls into two sizes or if there is any doubt on choosing the right size slings, always go for the smaller size sling first.

This resident sling guide is only an approximation, other factors which must be considered when selecting the appropriate sling are: resident's distribution of body weight (i.e. hips, thighs, upper body); resident's height, torso length; resident's physical condition (i.e. amputee, contractions, etc.).



### **WARNING**

The *Tenor* resident must only be lifted using a bariatric sling.

# Product description

## Parts referred to in this manual

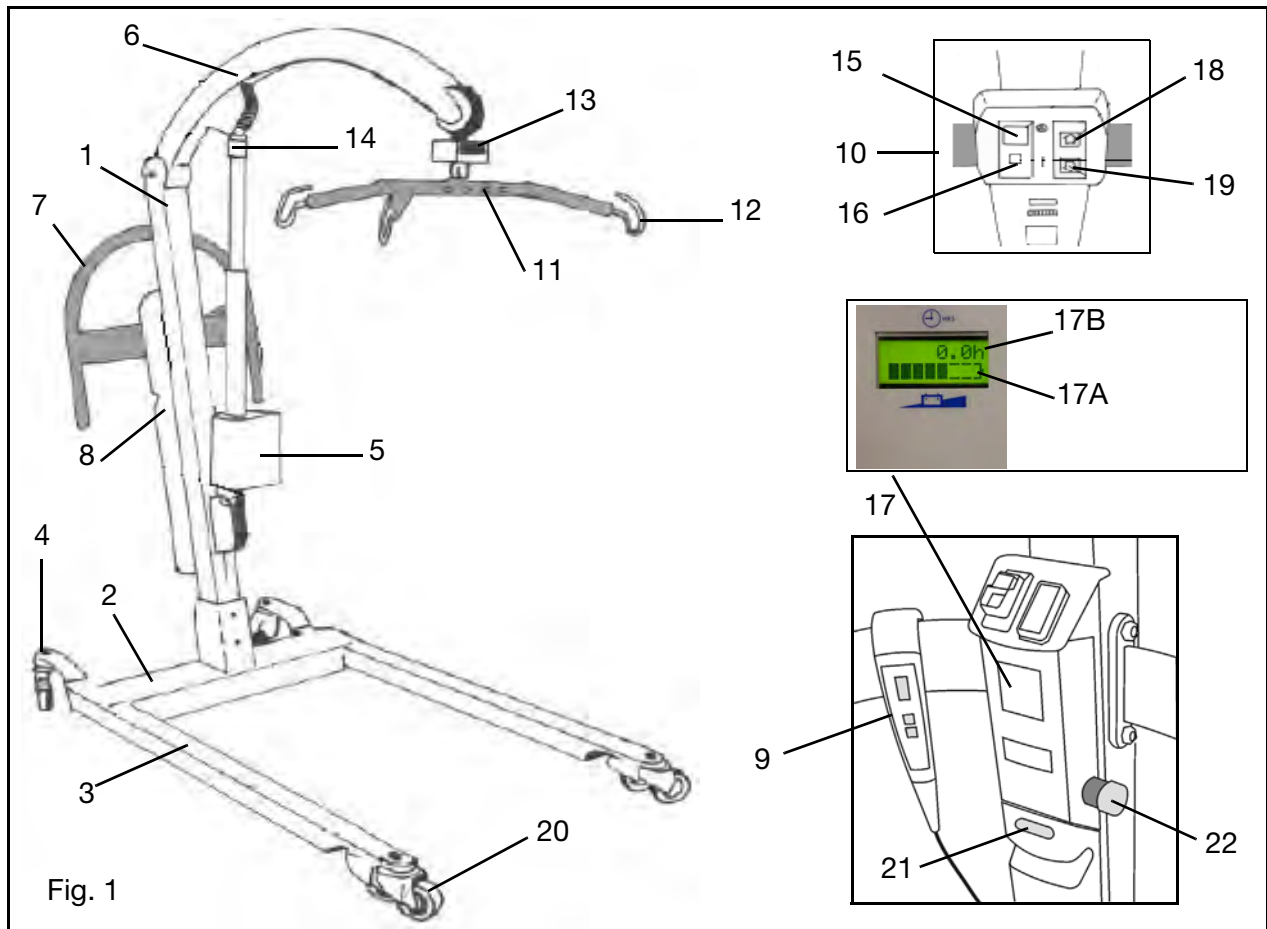

- |  |   |
|--|---|
| <ul style="list-style-type: none"> <li>1. Mast</li> <li>2. Chassis</li> <li>3. Adjustable width chassis legs</li> <li>4. Rear castors (braked)</li> <li>5. Lift actuator</li> <li>6. Jib</li> <li>7. Manoeuvring handle</li> <li>8. Battery pack</li> <li>9. Hand control (for raising and lowering)</li> <li>10. Electric / Battery compartment</li> <li>11. Spreader bar</li> <li>12. Sling attachment hooks</li> <li>13. Scale unit and display (if fitted)</li> <li>14. System failure lower override</li> <li>15. Power off button</li> </ul> | <ul style="list-style-type: none"> <li>16. Power on / Reset button</li> <li>17. LCD               <ul style="list-style-type: none"> <li>17A: Battery discharge indicator</li> <li>17B. Hour/Cycle meter</li> </ul> </li> <li>18. Dual control switch for raising UP</li> <li>19. Dual control switch for lowering DOWN</li> <li>20. Front castor</li> <li>21. Battery release button</li> <li>22. Emergency stop button</li> </ul> |
|--|---|

**Entire Product**  
 Type B. Applied part:  
 Protection against electric shock  
 in accordance with EN 60601-1.

# Product description

## CONTROLS AND FUNCTIONS

**Control Handset:** Press the appropriate button on the control handset to raise / lower the jib and to move the spreader bar. A small direction arrow is printed next to each button for function identification (See Fig. 2).

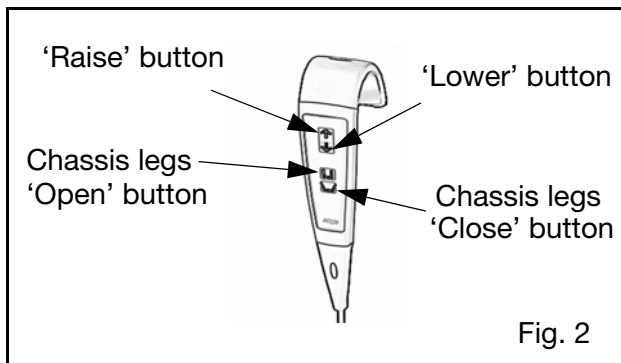

If pressure is released during any function, powered motion will stop immediately. Do not drop the handset into water, e.g. bath.

When not in use, the handset can be kept ready for use by hooking it over the loop at the rear of the mast.

**Dual control switch:** The raising / lowering of the jib can also be controlled from this switch, situated on the top of the electronics / battery compartment on the mast. Arrows on the switch are for function identification (See inset to Fig. 1). This switch will function, even if the handset cable has been unplugged.

**Emergency Stop Button (red):** If, in an emergency, you have to immediately stop any powered movement (other than by releasing pressure on the button on the handset) press the emergency stop button situated on the right hand side of the electronics / battery compartment on the mast (Fig. 1). Once the Emergency Stop button has been operated, it must be reset by turning the red cap until it pops out. Now the *Tenor* can be operated again.

**Power on / Reset button (green):** Located on the top control panel (Fig. 1). Press this button to turn on power to the *Tenor*. Also used to reset if the automatic overload fuse has operated (indicated by the button projecting outwards slightly). If the fuse has operated and, once reset, operates again, withdraw the lifter from use and contact Arjo or their appointed distributor.

**Power off button (red):** Located on the top control panel (Fig. 1). Press this button to turn off power to the *Tenor*.

**Automatic cut out:** If the lift is accidentally overloaded, trying to lift a resident heavier than permitted, an automatic 'cut out' operates to prevent the lift lifting a load in excess of one and a half a times the maximum allowed load. The lift motion will stop automatically.

**System failure lower override:** In case of control handset / dual switch malfunctioning, with a resident still supported by the sling, the lowering process can be continued using the system failure lower override, situated on the lift actuator tube (See Figs. 1 & 3).

To use this function, turn the red ring on top of the motor / actuator of the *Tenor* clockwise, using the resident's own weight to enable the mast to slowly lower. To stop lowering, simply stop turning the ring. Only use this function in the event of normal control failure. Do not use it for normal function lowering.

# Product description

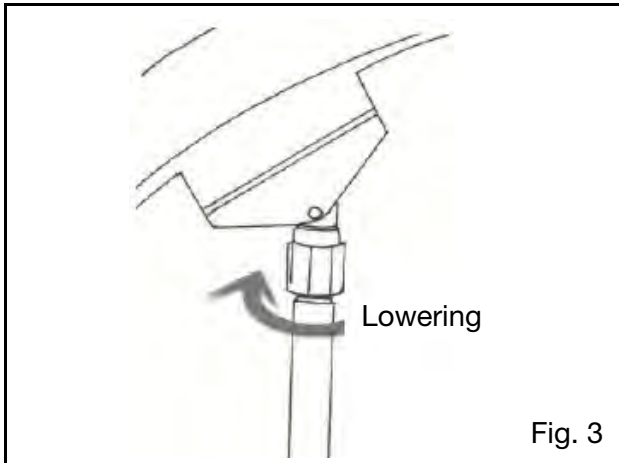

## WARNING

Before operating the “System failure lower override” to lower a resident, always ensure that a chair or suitable support is underneath ready to accept the resident.

**Automatic stop function:** Great care should be taken not to lower the jib and / or spreader bar onto the resident or any obstruction, particularly when the resident is standing up and weight bearing. If this should happen, the motor will continue to run but downward movement will be blocked by the obstruction. If this occurs, release pressure from the “lower” button immediately and operate the “raise” button until the equipment is clear. Then remove the obstruction.

**OverHeat Protection:** The buzzer will beep twice every 15s and “OverHeat” will display on the LCD. This happens when the caregiver exceeds the duty cycle for the lift actuator (2 min / 18 min) When it starts beeping, lifting and lowering is still possible. This function protects actuator against damage.

**Battery discharge indicator:** There is a small battery symbol on the bottom of the LCD. The battery symbol shows the level of battery charge. (See Fig. 1 and also the ‘Battery Charging’ section for complete description).

**Chassis castor brakes:** The chassis rear castors have brakes which can be foot operated (See Fig. 4).

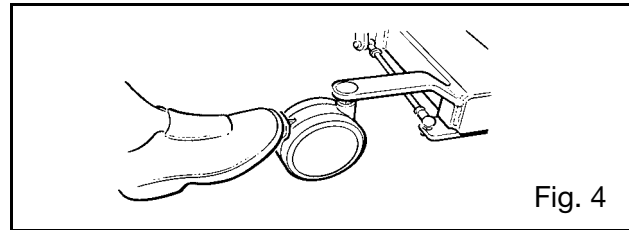

**Powered adjustable width chassis legs:** The mobile chassis legs can be opened to avoid obstructions e.g. chair legs. This can be done by operating the hand control, using only one hand and having the other free to hold onto the lift or care for the resident. Use the lower button to close the chassis legs and the upper one to open them (See Fig. 2).

Numerous positions can be obtained between fully opened and fully closed.

Transportation should be done with the chassis legs closed, it will be easier to push the lifter through doorways, etc.

When opening the chassis legs, the rear castors will close inwards.



## WARNING

When opening or closing the legs on a powered chassis, care must be taken not to allow anyone to stand in the way of the moving chassis legs.

**Hour/Cycle Meter:** On the top of the LCD display it shows the total duration of the lift and lowering operation (in hours - see item 17B, Fig. 1). The LCD can also show the number of cycles by simultaneously pressing the “raise” and “lower” button. This is primarily intended to help the caregiver calculate maintenance intervals.

**Scale (optional):** To use the scale, if available, refer to the *Scale IFU*.

# Using your Tenor

## CHECKLIST BEFORE USE

For a list of what to check before use, please read the “Preventive Maintenance Schedule” section of this document.

## PREPARATION

Unpack the battery supplied with the lift.



### CAUTION

A battery that is charged for the first time, or after a long storage period, must be charged until the charger indicates full charge (See “Battery charger IFU 001-24257”).

When the battery pack is fully charged, disconnect the mains power, then remove the pack from the charger and insert it fully into the *Tenor* battery position, located at the rear of the mast (See Fig. 1). Electrical connection is made automatically.

### Before approaching the resident



### WARNING

Never leave the resident unattended.

The caregiver should always tell the resident what he / she is going to do and have the correct sling size ready. Where possible, always approach the resident from the front.

To ensure maximum resident comfort, do not allow the resident to hold onto the spreader bar.

If required, the chassis legs may be opened to go around a chair, wheelchair or to avoid bed legs or any other obstruction.

### To lift a resident from a chair

Hold the sling up with the leg sections pointing downwards (See Fig. 5), to identify the orientation of the sling.

Before using a sling, first read the ‘Guidelines on the use of your sling’ and the sling label, which are delivered with the sling.

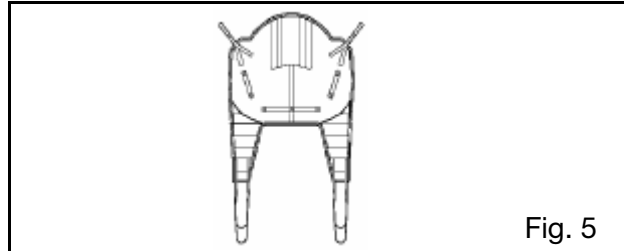

Fig. 5

Place the sling around the resident so that the bottom of the back support area reaches the bottom of the resident’s spine (it is not necessary to pull the sling under the resident). Ensure the head support area is behind the head (See Fig. 5).

Pull each leg section under each thigh so that they appear on the inside of the thighs (See Fig. 6).



Fig. 6

Ensure the sling is not folded or twisted under the resident (See Fig. 6).

Move the *Tenor* towards the resident, ensure the widest side of the spreader bar is facing towards the resident and is at, or just below, shoulder level (See Fig. 7).

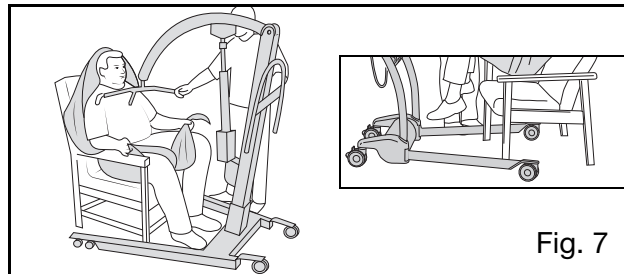

Fig. 7

# Using your Tenor

Ensure that the *Tenor* is close enough to be able to attach the shoulder loops of the sling to the spreader bar. To accomplish this, you may have to put the resident's feet on or over the chassis.

If the slings supplied have more than one loop attachment position, attach whichever loop seems appropriate to the size of the resident.

Once the *Tenor* is in position, attach the shoulder strap loops to the hooks on the spreader bar nearest to the resident (See Figs. 8 & 9).

The wider hook up points are for the shoulder sling loops and the narrower hook up points are for the leg sling loops (See Fig. 9).

If necessary, carefully lower the spreader bar a little bit using the control handset to enable the connection of the sling leg section loops, being careful not to lower it onto the resident.

The leg section loops should not be crossed over or twisted. Instead, the left leg section loop should be connected to the exact side hook above the leg being lifted (See Figs. 6 & 8).



## WARNING

When lifting or lowering the resident, ensure that no part of the resident's body can be caught between the lift's moving parts.

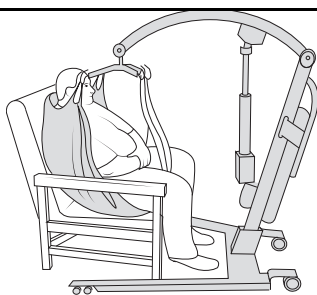

Fig. 8



## WARNING

Always check that all sling attachment loops are completely underneath and away from the safety latch on the hanger bar, before and during the commencement of the lifting cycle, in tension as the resident's weight is gradually taken up (See Figs. 8 & 9).

Raise the resident with the control handset, just high enough to move the resident clear of the seat, ensure their feet are clear of the floor.

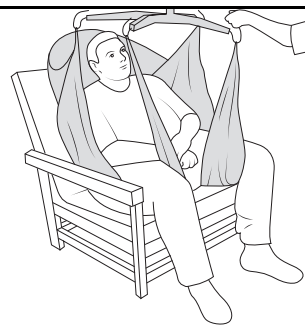

Fig. 9

Before transportation, turn the resident to face the caregiver and lower the individual to approximately normal chair height. This gives confidence and dignity and also improves the *Tenor* mobility.

## To return resident back to a chair

When returning to a chair, make sure the lift legs are positioned around the legs/wheels of the chair. To position the resident over the chair, use the lift handles, do NOT pull the sling. The resident suspended in sling should always remain in the centre of gravity. Use the hand control to lower the resident. (see Fig. 10).

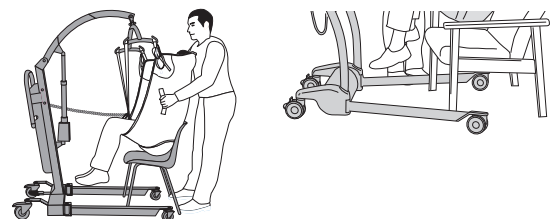

Fig. 10

# Using your Tenor

## To lift a resident from a bed



### WARNING

When lowering the resident back into a chair or when transferring from bed to chair, position the resident in such a way that he / she is fully supported by the chair when he / she is lowered.

Before lifting a person from a bed, ensure there is sufficient clearance underneath the bed to accommodate the *Tenor* chassis legs. Adjust width of chassis legs if necessary.

Position the resident onto the sling by rolling the resident towards you, then folding the sling in half and placing it behind the resident's back, so that the bottom edge of sling is aligned with bottom of the resident's spine (See Figs. 11, 12 & 13). Position the sling carefully so that when rolled back, the resident will lie centrally on the sling. Check that the head support area of the sling is in position.

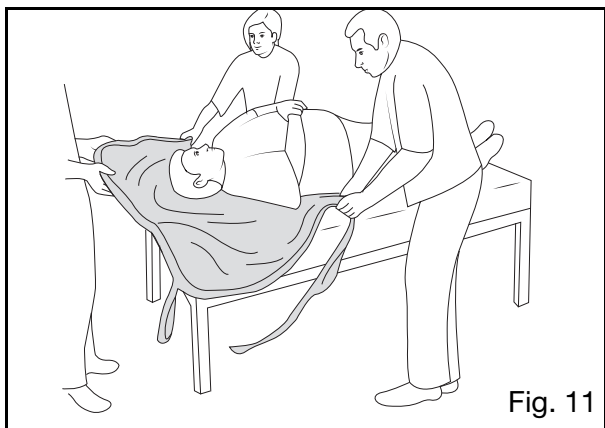

Fig. 11

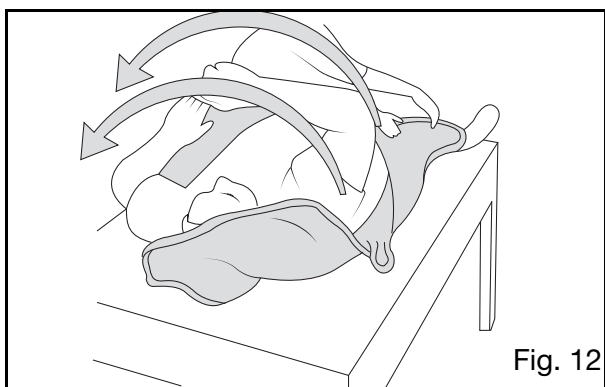

Fig. 12

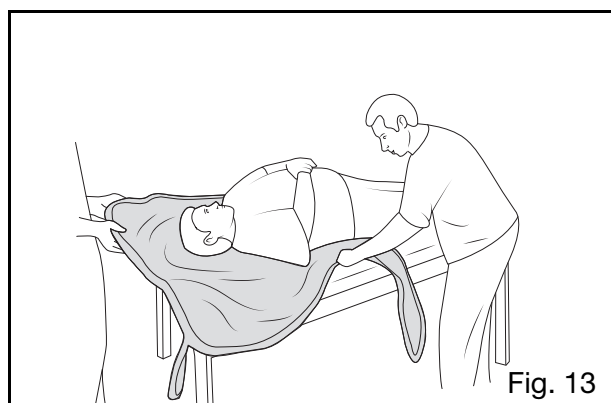

Fig. 13

When rolling the resident back onto the sling, roll them slightly in the opposite direction so that the folded part of the sling can be brought out.

Alternatively, the resident can be brought into a sitting posture. Then position the sling as detailed in the section "To lift a resident from a chair".

Using the adjustable width chassis, it is possible to make adjustments to chassis leg widths to assist manoeuvrability around obstructions, for example, bed legs.

Make sure the lift is positioned perpendicular to the bed. (see Fig. 14)

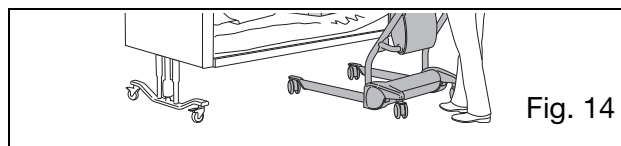

Fig. 14

Approach the bed with the open side of the *Tenor* spreader bar towards the resident's head.

Position the *Tenor* so that the spreader bar is just above and centrally situated over the resident.

Carefully lower the spreader bar until the shoulder attachment loops can be connected to the hooks nearest to the resident's head.

# Using your Tenor

Slide the leg sections of the sling under the resident's thighs and connect each loop on the side hook above each leg.

To make the lift more comfortable for the resident, it is recommended to lift the head end of the bed to semi-reclined position before commencing the lifting of the resident.

When correctly connected, operate the control handset to raise the resident from the bed. At all times when lifting and lowering, it is advisable to stay at the side of the resident to ensure they are in a comfortable position. This is also reassuring to the resident.

The resident suspended in sling should always remain in the centre of gravity.



## WARNING

Always check that the sling attachment loops are fully in position before and during the commencement of the lifting cycle, and in tension as the resident's weight is gradually taken up.

After lifting the resident, adjust to a comfortable height for transfer. The specially designed sling, together with its integral head support, enables one person to carry out a complete lifting function without additional help.

## To return resident to a bed

If returning the resident to a bed, move into the desired position above the bed and then lower using the control handset. When returning to a bed, make sure the lift is positioned perpendicular to the bed (see Fig. 15).

To position the resident over the bed, use the lift handles, do NOT pull the sling. The resident suspended in sling should always remain in the centre of gravity. Use the hand control to lower the resident.

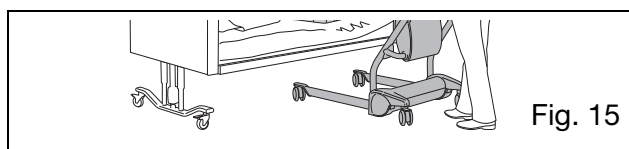

Only when the resident's body weight is fully supported by the bed, may the sling connection loops be detached and while still in sitting position, detach the sling from the hooks before reclining the resident to the bed.

Move the *Tenor* away before removing the sling from under the resident.

If transferring the resident to a chair, refer to the section "To return resident back to the chair".

# Using your Tenor

## To lift a resident from the floor

Put the sling around the resident as before, by using the rolling or seated position method. Depending on circumstances, space and / or position of the resident etc., open the chassis legs if necessary and carefully approach the resident with the front of the lift. Now lift the resident's legs over the chassis as shown in Figure 13, should the situation require it.

The resident's head and shoulders should be raised on pillows for comfort. This will also make it easier to attach the shoulder position attachment loops (See Fig. 16).

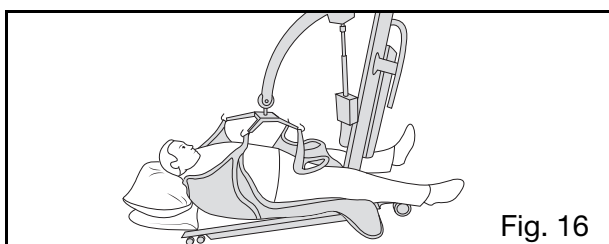

Fig. 16

Attach the shoulder strap attachment loops. It will probably be easier to attach the longest loops.

Some caregivers prefer to use a larger sling when lifting a resident from the floor.

Bring each leg section of the sling under the resident's thighs and attach each leg strap loop to the side hook above each leg (See Fig. 17).

Once securely connected, raise the resident carefully, staying in close proximity of the resident's legs at this stage of the lift to guide his / her legs safely over the lift until clear. Once raised from the floor, ensure the resident's legs are clear of the chassis before continuing to lift.

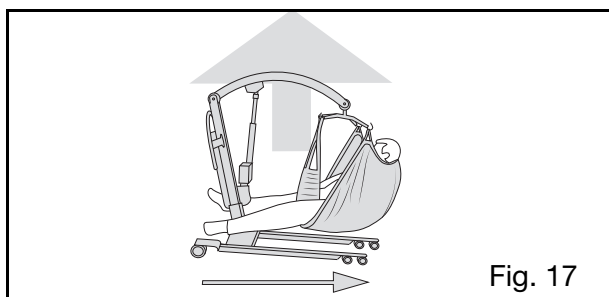

Fig. 17

Always move the *Tenor* in the direction shown in Fig. 17.

Raise the resident to a suitable height for transport in a semi-recumbent position.



## WARNING

Before and during the commencement of the lifting cycle, always check that all the sling attachment loops are fully in position and in tension as the resident's weight is gradually taken up and that the sling loops are underneath and away from the safety latch on the hanger bar.

If the leg sections of the sling tend to be fairly high in the crotch area, make adjustments for added comfort. The resident should be positioned in a chair or placed onto a bed in order to do this.

If the resident is prone to extensor spasm, he / she may be lifted with the *Tenor*, but special attention should be paid to supporting the legs during lifting.

Staff assessment should be made to determine if a spastic or combative resident requires an additional caregiver to assist.

Transportation of a resident is possible with the chassis legs open or closed, but manoeuvrability will be easier, especially through doorways, with the chassis legs closed. The resident should be positioned facing the caregiver and at a dignified height.

Apply the brakes on an incline.

# Battery charging



## WARNING

Only use the Arjo battery that is supplied with the *Tenor*.

Only use Arjo components that have been specifically designed for the purpose when charging batteries.

The *Tenor* incorporates a battery discharge indicator, situated on the rear of the battery / electronics compartment (See Battery discharge indicator in chapter Labels, item 5).



## WARNING

No smoking or naked flames in battery vicinity.

Do not place batteries near, or dispose of, in a fire.

Do not short circuit a battery.

Do not store batteries at temperatures in excess of 60°C (140°F).

Do not crush, puncture, open, dismantle, or otherwise mechanically interfere with batteries.



## WARNING

Should the battery casing become cracked and electrolyte come into contact with skin or clothing, wash immediately with water.

If the electrolyte contacts the eye, wash immediately with copious amounts of water and seek medical attention.

When disposing of batteries, contact the appropriate local authorities for advice.

The abbreviation "Pb" shown next to the recycling and trash bin symbols on the battery pack label is the element symbol for lead and indicates that the battery contains lead and therefore should not be disposed of in the normal manner but must be recycled.

# Battery charging

It is recommended that the battery is removed from the lifter and recharged when the battery discharge indicator displays 3 filled segments of battery charge and the buzzer beeps once every 10s. However, at this point lifting is still possible until the display shows one filled segment and the buzzer beeps continuously.

Best practice is to charge batteries at each shift to maximize battery life. Avoid totally discharging the battery, this will prolong battery life.

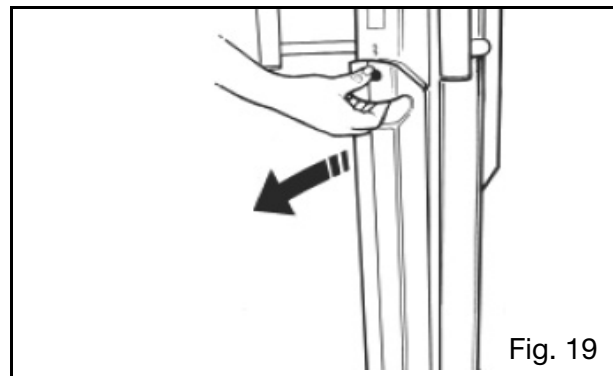

## CAUTION

A battery that is charged for the first time or after a long storage period must be charged until the charger indicates full charge.



## WARNING

Hold the pack firmly to ensure it does not drop and become damaged or cause personal injury.

A discharged battery must be left to charge until the charger indicates full charge.

To ensure the *Tenor* is always ready for use, it is recommended that a freshly charged battery pack is always available. This is achieved by having additional battery packs available and keeping one on charge while the other is in use.

The battery life is variable (2-5 years) and mainly depends on proper charging practices. To extend the battery life, the batteries must be charged at regular interval until the charger indicates full charge.

It may be considered good protocol to have a freshly charged battery pack ready for the start of every work shift.

Place the battery pack on charge as follows:

When the battery discharge indicator displays 3 filled segments, complete your lift cycle. Then take the lifter to a convenient location and remove the battery pack by holding the grip handle on the top and lift clear (See Fig. 19). Take the battery to the battery charger unit, ensure the battery is positioned securely (See “Battery charger IFU 001-24257).

When the battery pack is fully charged, disconnect the mains power, remove the battery pack from the charger and insert it back into the *Tenor* battery compartment.

Ensure that the green Power On / Reset button (Fig. 1) is pressed in.

*The Tenor* is now ready for use.



## CAUTION

After use, turn off the *Tenor* by pressing the red Power off button (Fig. 1) to reduce power consumption.

# Care of your TENOR

How often the following actions are taken, depends on how often the equipment is used.

Unless otherwise stated, before each and every use follow the cleaning, care and inspection procedures described in this section.



## WARNING

It is recommended that resident lifters, equipment, accessories and slings supplied by Arjo are regularly cleaned and / or disinfected between each resident use if necessary, or daily as a minimum. If the slings, lifters and equipment need cleaning or are suspected of being contaminated, follow the cleaning and / or disinfection procedures below, before re-using the equipment. This is especially important when using the same equipment for another resident to minimize the risk of cross infection.

For cleaning your lifter, equipment and accessories wipe down with a damp cloth using warm water to which a mild detergent has been added.

For disinfection of contaminated lifters, equipment and accessories, use the preferred method of wiping the product completely with “hard surface disinfectant wipes” that are supplied impregnated with a mild detergent.

A rubbing action will be necessary when using the wipes to promote effective disinfection of the surfaces.



## WARNING

Cleaning and disinfection products must be used in accordance with the manufacturer's instructions and suitable eye, hand and clothing protection must be worn at all times when handling disinfectants.

## Servicing Advice



## CAUTION

Do not use the product in wet areas, as this could cause problems with electrical components or internal corrosion.

If a hot air dryer is used to dry the lifter, the temperature must not exceed 90°C (194°F)

Do not use petroleum based solvents or similar. This may damage plastic parts.



## WARNING

Arjo recommends that the *Tenor* is maintained at regular intervals. See Arjo Preventive Maintenance Schedule.

Spare parts, if required, are available from Arjo or their approved distributors. Parts list and circuit diagrams are available from Arjo or their approved distributors upon request.

Special tools are required for certain component replacement.

**UK LIFTERS ONLY:** Important new legislation came into force on 5th December 1998, which has an impact on the schedule of service for your resident lifter(s), variable height baths and other raising and lowering equipment. The Lifting Operations and Lifting Equipment Regulations (LOLER) 1998 and the Provision and Use of Work Equipment Regulations (PUWER 98) must be satisfied by the duty holder. A scheme of six monthly through examinations has been devised to comply with the law and details can be obtained from Arjo Service UK.

The simplest, safest and most effective way to maintain your product in good working order, is to have it methodically and professionally serviced by an Arjo approved engineer using Arjo approved spare parts

# Care of your TENOR

For information on service and maintenance contracts, please contact your local Arjo distributor.

## Slings



### CAUTION

The sling should be checked before and after using with each resident and if necessary, washed according to the instructions on the sling. Also refer to the sling instruction sheet.



### WARNING

When using your sling, always read “the Guidelines on the use of your sling” that are delivered with the sling.

### Environmental Advice

When disposing of any items associated with the equipment, contact the appropriate local authority for advice.

With regard to laundering, the sling should not be classified as linen, but as an accessory to a resident transfer lifter and therefore classified as a medical device. Slings should be cleaned and disinfected only in strict accordance with the manufacturer’s instructions.



### WARNING

Mechanical pressure should be avoided during the washing and drying procedure e.g. rolling and pressing, as these can damage parts vital to the safe and comfortable operation of the sling.



### CAUTION

Washing and drying procedures must not exceed 90°C (194°F). Wash using normal detergents, do not iron. Also refer to the sling instruction sheet.

It is essential that resident lifters, equipment, accessories and slings supplied by Arjo are regularly cleaned and/or disinfected between each resident use if necessary, or daily as a minimum. If the slings, lifters and equipment need cleaning or are suspected of being contaminated, follow the cleaning and/or disinfection procedures below, before re-using the equipment. This is especially important when using the same equipment for another resident to minimize the risk of cross infection.



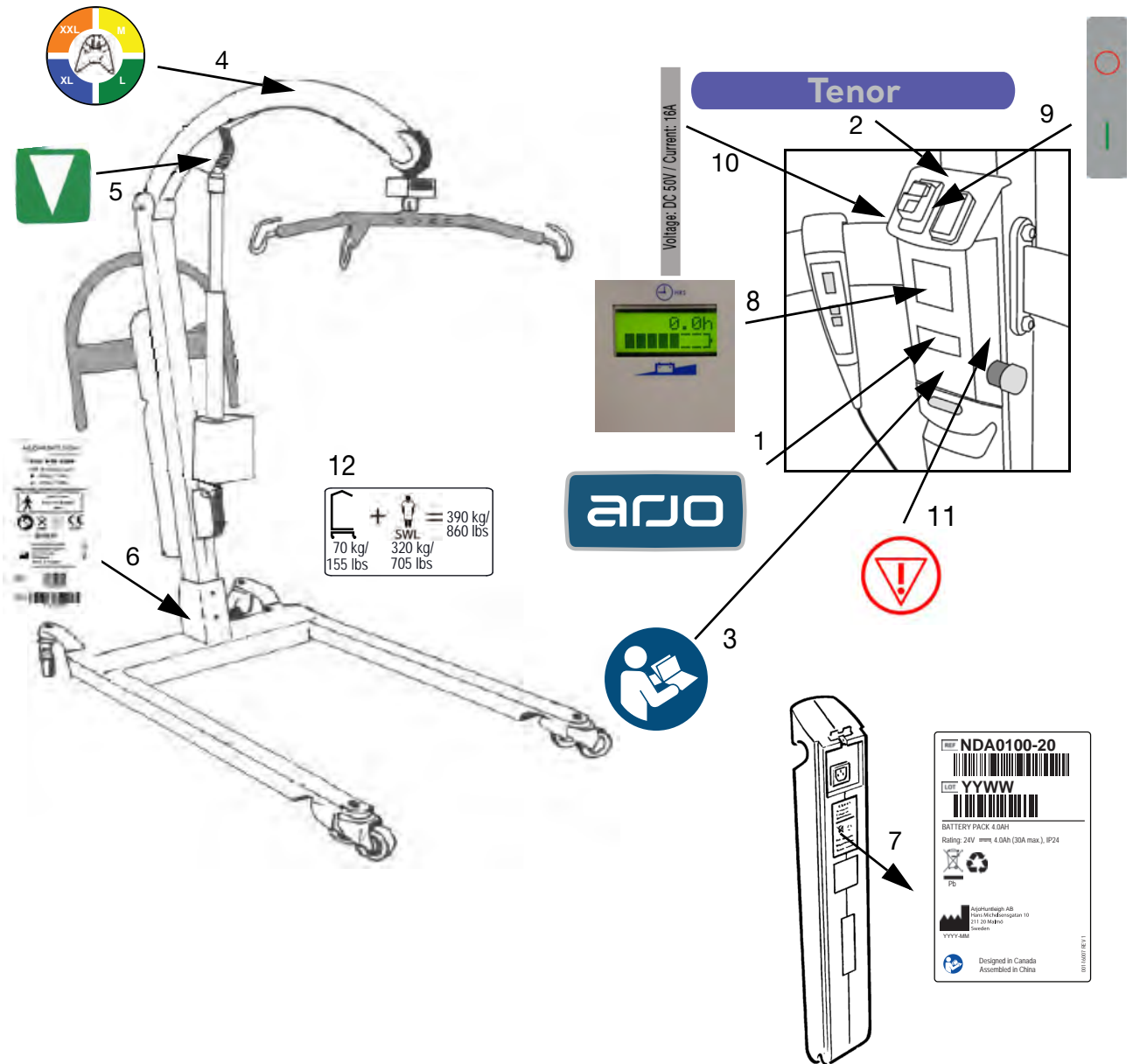



# Labels



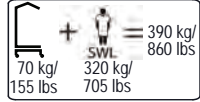

## Key to labels:

- |   |   |
|---|---|
| 1. Arjo logo  | 7. Battery instruction / Recycling information    |
| 2. Product name                                       | 8. Hour/Cycle meter / Battery discharge indicator |
| 3. Attention - Read operating instructions before use | 9. On / off label                                 |
| 4. Sling size guide                                   | 10. Voltage / current reading                     |
| 5. System failure lower override identification       | 11. Emergency stop button label                   |
| 6. Safe Working Load and Serial number / chassis ref. | 12. Maximum total weight of lift (lift + patient) |

# Labels

Symbol Explanation	
	Refer to instruction manual/ booklet - Instructions for use should be read
	Separate electrical and electronic components for recycling in accordance with the European Directive 2012/19/EU (WEEE)
	Type B Applied part: protection against electrical shock in accordance with EN/IEC 60601-1.
	CE marking indicating conformity with European Community harmonised legislation Figures indicate Notified Body supervision when equipment is fitted with scale.
	Indicates the product is a Medical Device according to EU Medical Device Regulation 2017/745
	Total mass of equipment including its safe working load.
	Name and address of the manufacturer
	Manufacturing date

Symbol Explanation	
	Unique device identifier
	Indicates NRTL certification through TÜV SÜD.
	CE marking indicating conformity with European harmonised legislation. (Equipment without scale).

## UK Symbol explanation

This section is only applicable to United Kingdom (UK) market when UK marking is applied to the Arjo medical device labelling.

	UK marking indicating conformity with UK Medical Devices Regulations 2002 (SI 2002 No 618, as amended) Figures indicate UK Approved Body supervision.
---	--

### UK Responsible Person & UK Importer:

**Arjo (UK) Ltd, ArjoHuntleigh House, Houghton Regis. LU5 5XF**

Is the appointed UK Responsible Person as defined in UK Medical Devices Regulations 2002 (SI 2002 No 618, as amended).

For Northern Ireland (NI) CE marking will still apply until further amendment to applicable regulations.

# Technical specification

## Component Weights

	kg	lbs
Tenor complete with scale, battery .....	70	155
Tenor complete without scale .....	69.1	152.3
Maximum total weight of lift (lift + patient) .....	390	860

In normal use, the *Tenor* can be broken up into two parts:

Battery pack.....	3.8	8.4
Tenor (without Battery pack).....	65.3	144
Tenor with scale (without Battery pack).....	66.4	146.4

The *Tenor* is not intended to be broken up into more than these parts.

## Maximum Lifting Capacities (Safe Working Load - SWL)

Tenor .....	320	705
All slings - Please verify with the SWL on the sling label		

## Electrical

Battery type.....	Rechargeable - sealed lead acid
Battery part number .....	NDA0100-20
Battery capacity .....	4Ah
Lift - Protection class - Ingress of fluid.....	IPX4
Lift - Protection class - Electrical shock protection.....	Internally powered equipment
Lift nominal voltage.....	24V
Fuse - Overload .....	16A (thermal cutout)
Fuse - PCBA.....	20A (time delay)
Operating forces - Handset.....	2.5N

See Battery Charger IFU 001-24257 for technical specifications

	Duty cycle	Max volts	Max amps
Lift actuator .....	10% – 1 min / 9 min	24 V	10 A
“V” Chassis actuator .....	10% – 2 min / 18 min	24 V	2 x 2,3 A

Mode of operation: intermittent

## Environment

### Ambient temperature range

Operation .....	+10°C to +40°C (+50°F to 104°F)
Transport and Storage.....	-20°C to +70°C (-4°F to +158°F)

### Relative humidity range

Operation .....	30% - 75%
Transport and Storage.....	10% - 80%

### Atmospheric pressure range

Operation .....	800 - 1060 hPa
Transport and Storage.....	500 - 1100 hPa

## End of Life Disposal

- All batteries in the product must be recycled separately. Batteries are to be disposed in accordance with national or local regulations.
- Slings including stiffeners/stabilizers, padding material, any other textiles or polymers or plastic materials etc. should be sorted as combustible waste.
- Lift systems having electrical and electronic components or an electrical cord should be disassembled and recycled per Waste of Electrical and Electronic Equipment (WEEE) or in accordance with local or national regulation.
- Components that are primarily be made up of different kinds of metal (containing more than 90% metal by weight) for example sling bars, rails, upright supports, etc., should be recycled as metals.

# Technical specification

## Maximum sound power level

In accordance with ISO3746

Unloaded ..... 62 dB (A)

Fully loaded ..... 62 dB (A)

## Hoist Dimensions

(drawing on page 24)

A. Max. external length: 1485 mm / 58.5"

B. Max. internal length: 1030 mm / 40.6"

C. Max. external width: 1400 mm / 55.1"

D. Max. internal width: 1270 mm / 50"

E. Min. external width: 820 / 32.3"

F. Min. internal width: 700 / 27.6"

G. Height of C.S.P. at max. hoisting reach: 1405 mm / 55.3"

H. Min. distance wall to C.S.P. at max. reach (legs spread): 335 mm / 13.2"

I. Min. height of C.S.P.: 800 mm / 31.5"

J. Min. distance wall to C.S.P. at min. height (legs spread): 530 mm / 20.9"

K. Max. height of C.S.P.: 2025 mm / 79.7"

L. Min. distance wall to C.S.P. at max. height (legs spread): 545 mm / 21.5"

M. Hoisting range: 1225 mm / 48.2"

N. Min. clearance: 20 mm / 0.8"

O. Max. height: 102 mm / 4"

P. Turning radius: 1700 mm / 66.9"

Q. Max. height of Sling attachment hooks (lift with scale): 1750 mm / 68.9"

Max. height of Sling attachment hooks (lift without scale): 1860 mm / 73.2"

R. Min. height of Sling attachment hooks (lift with scale): 525 mm / 20.7"

Min. height of Sling attachment hooks (lift without scale): 635 mm / 25"

**Note: 'C.S.P.' stands for 'Central Suspension Point': a reference point on the lift used for measurements. On the Tenor, the C.S.P. is the clips attachment point closest to the resident at the start of the lifting cycle.**

**Technical specifications may be revised and changed without prior notice.**

# Technical specification

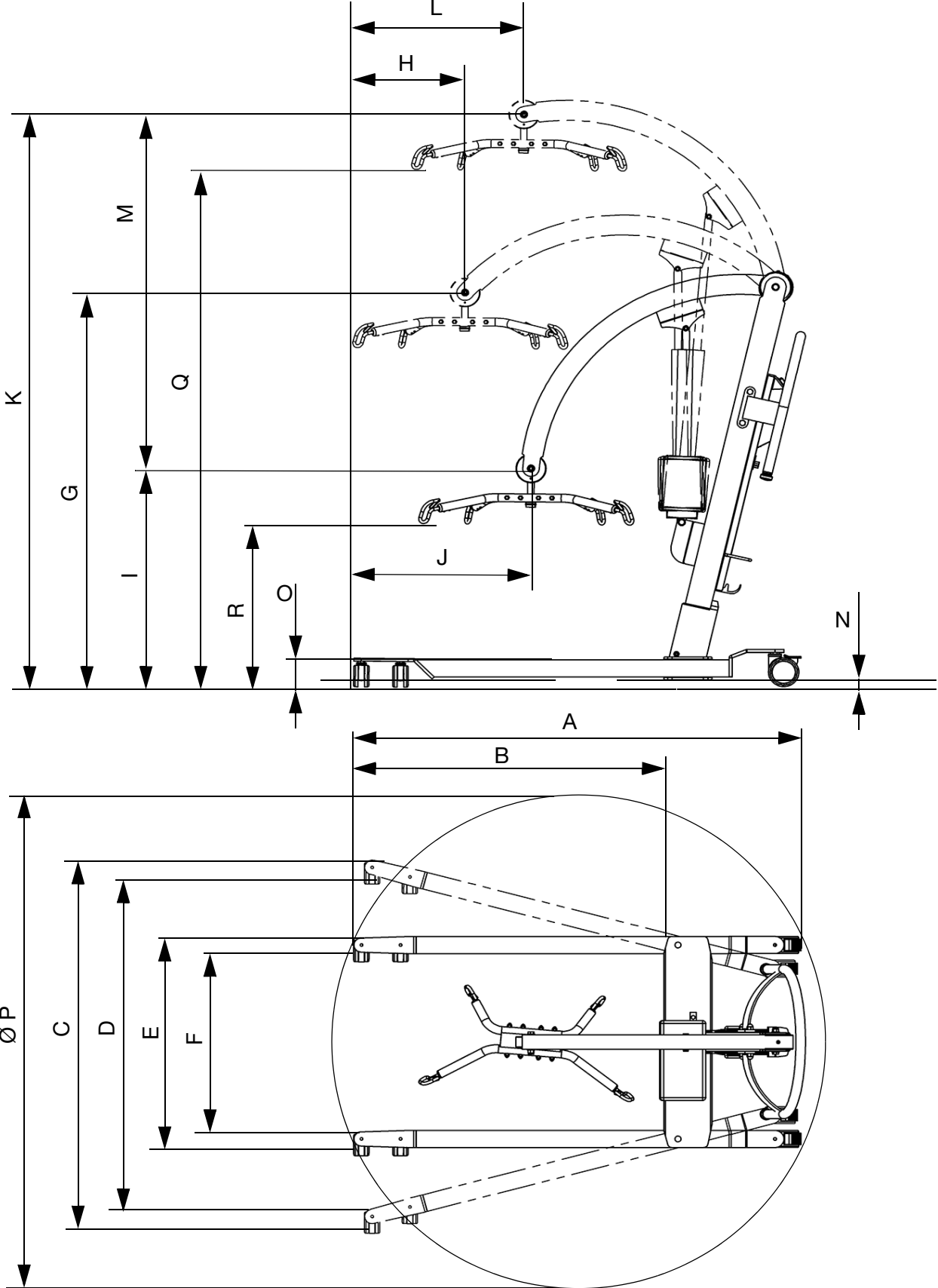

# Troubleshooting / Problem Solving

**Problem description:**

The *Tenor* is (brand new and) not functioning at all.

**Probable cause:**

Power Off button (red) is still engaged.

**Solution:**

Please press the Power on / Reset button (green).

**Problem description:**

The *Tenor* is raising and lowering slower than normal.

**Probable cause:**

Low battery power level.

**Solution:**

Please check LCD battery discharge indicator the *Tenor*. This should indicate the power level of the battery. In case of doubt, change the battery on the lift with a fully charged battery and compare performance. In case of low battery power level, please charge the battery and use a fully charged one to continue using the *Tenor*.

**Problem description:**

The *Tenor* is not raising or lowering, and/or the chassis can not be opened or closed.

**Probable cause:**

Hand control is damaged.

**Solution:**

Please try operating the lift with the Dual Up/ Down Control situated on the mast of the *Tenor*. Should the lift fully function when these controls are used, and should the lift not fully function when using the hand control, the hand control should be replaced.

**Problem description:**

As above, the *Tenor* does not function properly, not with the hand control, neither with the Dual Up-Down Control switches.

**Probable cause:**

Electronics PCB is malfunctioning or actuator (on lifting arms or in chassis) is malfunctioning

**Solution:**

Please contact your Arjo dealer or Arjo approved service engineer.

# Troubleshooting / Problem Solving

**Problem description:**

While pressing the 'Chassis legs open' button, the *Tenor* makes a noise, "overload" displays on the LCD and the buzzer beeps continuously but the chassis legs are not opening.

**Probable cause:**

An obstruction is blocking the chassis legs.

**Solution:**

Please remove the obstruction and check thoroughly for damage before continuing the lifting cycle. When in doubt, use the System Failure Lowering Override to put the resident back into a safe seated position before removing the *Tenor* and placing it out of order till it has been inspected and approved for safe working by an Arjo approved engineer.

**Problem description:**

The functions on the *Tenor* are not working properly

**Probable cause:**

Malfunction of EMC of the hoist making the hoist vulnerable for radiation influences of other machinery

**Solution**

Operate the *Tenor* in an environment without influence of radiation.

**Problem description:**

Unexpected movement of the hoist

**Probable cause:**

Two control buttons pressed simultaneously; faulty hand control, push buttons or electronics

**Solution**

Release both control buttons. If this doesn't work, press the red Emergency Stop button and remove the battery. Use the System Failure Lowering Override to put the resident back into a safe seated position before removing the *Tenor* and placing it out of order till it has been inspected and approved for safe working by an Arjo approved engineer.

**Problem description:**

"OverHeat" displays and the buzzer beeps twice every 15s.

**Probable cause:**

Operator excess the actuator duty cycle (2 min ON and 18 min OFF)

**Solution**

Finish operating cycle and wait 18 min. The operation prevents the actuator against damage.

# Preventive Maintenance Schedule

The *Tenor* is subject to wear and tear, and the following actions must be performed when specified to ensure that the product remains within its original manufacturing specification.

	<p><b>WARNING</b></p> <p>The points on this checklist are the minimum the manufacturer recommends. In some cases due to heavy use of the product and exposure to aggressive environment, more frequent inspections shall be carried out. Continuing to use this product without conducting regular inspections or when a fault is found will seriously compromise the user and residents' safety. Local regulations and standards may be higher than the manufacturers. Preventive maintenance specified in this manual can prevent accidents.</p> <p>The parts which are entitled 'Checks to be performed by Qualified Arjo personnel' have to be carried out by qualified personnel, using the correct tools and knowledge of procedures. Failure to meet these requirements could result in personal injuries and / or unsafe product.</p>
---	---

**Note: Product cannot be maintained and serviced while in use with the patient.**

## Preventive Maintenance Schedule

Action/Check	Before each use	Every day	Every Week	Every 6 months	Every 12 months
<b>CAREGIVER OBLIGATIONS</b>					
<b>ARJO SLINGS</b>					
Examine the slings, their straps and attachment loops. If any part of the sling or its straps is frayed or any one of the loops is damaged, the sling must be withdrawn from use immediately and replaced with a new sling.	X				
Where necessary, after resident use, carry out decontamination of the sling in accordance with Arjo and local decontamination regulations	X				
Read the Guidelines on the use of your sling.	X				
<b>ARJO BATTERY CHARGER</b>					
Visually examine the battery charger for loose connectors, cut wires and damage to the casing. Do not use if found loose, cut or damaged in any way	X				
<b>ARJO TENOR</b>					
Make sure the battery is charged before use. If not adequately charged, replace with a fully charged battery.	X				
When necessary, after each resident use, carry out decontamination of the Arjo <i>Tenor</i> in accordance with Arjo Operating Instructions and local regulations.	X				
Make sure the battery pack is in a good state of charge. Charge the battery at the end of each working shift until the charger indicates full charge.		X			
The lifter is fitted with a warning device. When the battery discharge indicator reaches the red flashing light, the battery must be charged as soon as possible		X			
Make sure all castors rotate freely and the two rear brakes lock.		X			
Make sure the castor-mounting pin is tight on the chassis and chassis legs and the castor tread is not damaged. Be sure to remove any fluff, hair or debris from the wheels to ensure their proper functioning.		X			
Check that all external fittings are secure and that all screws and nuts are tight.		X			

# Preventive Maintenance Schedule

Examine all exposed parts, especially where there is personal contact with the resident's body. Make sure no cracks or sharp edges have developed that could cause resident or user injury or have become unhygienic. Replace or clean/disinfect them where necessary.		X			
Make sure all instruction labels are firmly attached and readable.		X			
Make sure that the sling attachment is visually inspected. Any component found frayed or damaged, must be withdrawn from service immediately and replaced.		X			
For longevity, charge batteries until the charger indicates full charge.			X		
Operate the lift through its full range. Make sure the lift can operate in a normal and smooth manner.			X		
Open and close the chassis legs and check for full travel and smooth movement.			X		
Examine the condition of the handset and its cable. Withdraw from service immediately and replace with new cable and handset assembly if damaged. Examine and ensure all external fittings are secure and all screws, bolts and nuts are tight.			X		
Examine the integrity of the loop lock assemblies on the hangar bar.			X		
<b>CHECKS TO BE PERFORMED BY QUALIFIED ARJO PERSONNEL</b>					
Perform the weekly PMS checks				X	
Test the Automatic Stop Function as follows. Raise or lower the lift arm until the spreader bar reaches eye height. Now hold the lift arm with your hand while using the remote control handset to lower the lift arm. The actuator will continue to run, but the lift arm is held up by your hand. Release the handset button and slowly lower the lift arm you are holding until you feel it is supported by the actuator.				X	
Test the Emergency Stop Feature by operating the cable remote control handset to raise or lower the Lift arm. While operating, press the emergency stop button. Powered movement must stop immediately. Repeat the test, this time operating the opening and the closing of the chassis legs.				X	
Examine the sling attachment points on the lift arm. If found damaged, replace the lift arm.				X	
Examine the clip assembly for damage or deterioration. Replace if necessary.				X	
Perform the 6 monthly PMS checks					X
Examine the actuator.					X
Examine the clip assembly for damage or deterioration. Replace if necessary.					X
Examine the Foot bracket condition.					X
Make sure the chassis legs are square to the chassis member.					X
Do a torque tightening check of the following: (a) Castors to the chassis and legs 4 off - 25 Nm (18lb ft) (b) Chassis leg pivot bolts 2 off - 47 Nm (35 lb ft)					X

# Electromagnetic Compatibility (EMC)

Product has been tested for compliance with current regulatory standards regarding its capacity to block EMI (electromagnetic interference) from external sources.

Some procedures can help reduce electromagnetic interferences:

- Ensure that other devices in patient-monitoring and/or life-support areas comply to accepted emissions standards.

	<p><b>WARNING</b></p> <p>Use of this equipment adjacent to or stacked with other equipment should be avoided because it could result in improper operation. If such use is necessary, this equipment and the other equipment should be observed to verify that they are operating normally.</p>
---	---

	<p><b>WARNING</b></p> <p>Portable RF communications equipment (including peripherals such as antenna cables and external antennas) should be used no closer than 30 cm (12 inches) to any part of the Tenor, including cables specified by the manufacturer. Otherwise, degradation of the performance of this equipment could result.</p>
---	--

	<p><b>WARNING</b></p> <p>Use of accessories, transducers and cables other than those specified or provided by the manufacturer of this equipment could result in increased electromagnetic emissions or decreased electromagnetic immunity of this equipment and result in improper operation.</p>
---	--

Intended Environment: Professional Healthcare Facility Environment

Exceptions: HF Surgical Equipment and the RF Shielded room of an ME SYSTEM for magnetic resonance imaging

Guidance and manufacturer's declaration: electromagnetic emissions (EMI)		
Emissions test	Compliance	Guidance
RF emissions CISPR11	Group 1	This equipment uses RF energy only for its internal functions. Therefore its RF emissions are very low and are not likely to cause any interference in nearby electronic equipment.
RF emissions CISPR 11	Class B	This equipment is suitable for use in all establishments, including domestic establishments and those directly connected to the public low voltage power supply network that supplies buildings used for domestic purposes.

<b>Guidance and manufacturer's declaration: electromagnetic immunity</b>		
<b>Immunity test</b>	<b>IEC 60601-1-2 test level</b>	<b>Compliance level</b>
Electrostatic discharge (ESD) EN 61000-4-2	±2 kV, ±4 kV, ±8 kV, ±15 kV air ±8 kV contact	±2 kV, ±4 kV, ±8 kV, ±15 kV air ±8 kV contact
Conducted disturbances induced by RF fields EN 61000-4-6	3V in 0.15 MHz to 80 MHz  6 V in ISM and amateur radio bands between 0.15 MHz and 80 MHz 80% AM at 1 kHz	3V in 0.15 MHz to 80 MHz  6 V in ISM and amateur radio bands between 0.15 MHz and 80 MHz 80% AM at 1 kHz
Radiated RF electromagnetic field EN 61000-4-3	Professional Healthcare environment 3 V/m 80 MHz to 2.7 GHz 80% AM at 1 kHz	Professional Healthcare environment 3 V/m 80 MHz to 2.7 GHz 80% AM at 1 kHz
Proximity fields from RF wireless communications equipment EN 61000-4-3	385 MHz - 27 V/m  450 MHz - 28 V/m 710, 745, 780 MHz - 9V/m 810, 870, 930 MHz - 28 V/m 1720, 1845, 1970, 2450 MHz- 28 V/m 5240, 5500, 5785 MHz - 9 V/m	385 MHz - 27 V/m  450 MHz - 28 V/m 710, 745, 780 MHz - 9 V/m 810, 870, 930 MHz - 28 V/m 1720, 1845, 1970, 2450 MHz - 28 V/m 5240, 5500, 5785 MHz - 9 V/m
Power frequency Magnetic field EN 61000-4-8	30 A/m  50 Hz or 60 Hz	30 A/m  50 Hz
Proximity magnetic fields EN 61000-4-39	134.2 kHz - 65 A/m  13.56 MHz - 7,5 A/m	134.2 kHz - 65 A/m  13.56 MHz - 7,5 A/m

**AUSTRALIA**

Arjo Australia  
 Building B, Level 3  
 11 Talavera Road  
 Macquarie Park, NSW, 2113,  
 Australia  
 Phone: 1800 072 040

**BELGIQUE / BELGIË**

Arjo Belgium  
 Evenbroekveld 16  
 9420 Erpe-Mere  
 Phone: +32 (0) 53 60 73 80  
 Fax: +32 (0) 53 60 73 81  
 E-mail: info.belgium@arjo.com

**BRASIL**

Arjo Brasil Equipamentos Médicos Ltda  
 Avenida Piraiba, 352, Sala 18  
 Centro Comercial Jubran - Barueri/SP –  
 Brazil  
 CEP: 06460-121  
 Phone: 55-11-3588-5088  
 E-mail: vendas.latam@arjo.com  
 E-mail: servicios.latam@arjo.com

**CANADA**

Arjo Canada Inc.  
 90 Matheson Boulevard West  
 Suite 350  
 CA-MISSISSAUGA, ON, L5R 3R3  
 Tel/Tél: +1 (905) 238-7880  
 Free: +1 (800) 665-4831  
 Fax: +1 (905) 238-7881  
 E-mail: info.canada@arjo.com

**ČESKÁ REPUBLIKA**

Arjo Czech Republic s.r.o.  
 Škrátova 490/12  
 120 00 Praha 2  
 Czech Republic  
 Phone No: +420225092307  
 E-mail: info.cz@arjo.com

**DANMARK**

Arjo A/S  
 Industriparken 21A  
 2750 BALLERUP, Denmark  
 Tel: +45 49 13 84 86  
 Fax: +45 49 13 84 87  
 E-mail: dk\_kundeservice@arjo.com

**DEUTSCHLAND**

Arjo GmbH  
 Peter-Sander-Strasse 10  
 DE-55252 MAINZ-KASTEL  
 Tel: +49 (0) 6134 186 0  
 Fax: +49 (0) 6134 186 160  
 E-mail: info-de@arjo.com

**ESPAÑA**

ARJO IBERIA S.L.  
 Poligono Can Salvatella  
 c/ Cabanyes 1-7  
 08210 Barberà del Valles  
 Barcelona - Spain  
 Telefono 1: +34 900 921 850  
 Telefono 2: +34 931 315 999

**FRANCE**

Arjo France  
 10 Rue Denis Papin  
 CS 62535  
 59652 VILLENEUVE D'ASCQ CEDEX  
 Tél: +33 (0) 3 20 28 13 13  
 Fax: +33 (0) 3 20 28 13 14  
 E-mail: info.france@arjo.com

**HONG KONG**

Arjo Hong Kong Limited  
 Room 411-414, 4/F, Manhattan Centre,  
 8 Kwai Cheong Road, Kwai Chung, N.T.,  
 HONG KONG  
 Tel: +852 2960 7600  
 Fax: +852 2960 1711

**ITALIA**

Arjo Italia S.p.A.  
 Via Giacomo Peroni 400-402  
 IT-00131 ROMA  
 Tel: +39 (0) 6 87426211  
 Fax: +39 (0) 6 87426222  
 E-mail: Italy.promo@arjo.com

**MIDDLE EAST**

Arjo Middle East FZ-LLC  
 Office 908, 9th Floor,  
 HQ Building, North Tower,  
 Dubai Science Park,  
 Al Barsha South  
 P.O. Box 11488, Dubai,  
 United Arab Emirates  
 Direct +971 487 48053  
 Fax +971 487 48072  
 Email: Info.ME@arjo.com

**NEDERLAND**

Arjo Nederland BV  
 Biezenwei 21  
 4004 MB TIEL  
 Postbus 6116  
 4000 HC TIEL  
 Tel: +31 (0) 344 64 08 00  
 Fax: +31 (0) 344 64 08 85  
 E-mail: info.nl@arjo.com

**NEW ZEALAND**

Arjo Ltd  
 34 Vestey Drive  
 Mount Wellington  
 NZ-AUCKLAND 1060  
 Tel: +64 (0) 9 573 5344  
 Free Call: 0800 000 151  
 Fax: +64 (0) 9 573 5384  
 E-mail: nz.info@Arjo.com

**NORGE**

Arjo Norway AS  
 Olaf Helsets vei 5  
 N-0694 OSLO  
 Tel: +47 22 08 00 50  
 Faks: +47 22 08 00 51  
 E-mail: no.kundeservice@arjo.com

**ÖSTERREICH**

Arjo Austria GmbH  
 Lemböckgasse 49 / Stiege A / 4.OG  
 A-1230 Wien  
 Tel: +43 1 8 66 56  
 Fax: +43 1 866 56 7000

**POLSKA**

Arjo Polska Sp. z o.o.  
 ul. Ks Piotra Wawrzyniaka 2  
 PL-62-052 KOMORNIKI (Poznań)  
 Tel: +48 691 119 999  
 E-mail: arjo@arjo.com

**PORTUGAL**

Arjo em Portugal  
 MAQUET Portugal, Lda.  
 (Distribuidor Exclusivo)  
 Rua Poeta Bocage n.º 2 - 2G  
 PT-1600-233 Lisboa  
 Tel: +351 214 189 815  
 Fax: +351 214 177 413  
 E-mail: Portugal@arjo.com

**SUISSE / SCHWEIZ**

Arjo Switzerland AG  
 Zelglimatte 3 / Haus H  
 6260 Reiden  
 Switzerland  
 Tél/Tel: +41 (0) 61 337 97 77  
 Fax: +41 (0) 61 311 97 42

**SUOMI**

Arjo Scandinavia AB  
 Riihitontuntie 7 C  
 02200 Espoo  
 Finland  
 Puh: +358 9 6824 1260  
 E-mail: Asiakaspalvelu.finland@arjo.com

**SVERIGE**

Arjo International HQ  
 Hans Michelsensgatan 10  
 SE-211 20 MALMÖ  
 Tel: +46 (0) 10 494 7760  
 Fax: +46 (0) 10 494 7761  
 E-mail: kundservice@arjo.com

**UNITED KINGDOM**

Arjo UK and Ireland  
 Houghton Hall Park  
 Houghton Regis  
 UK-DUNSTABLE LU5 5XF  
 Tel: +44 (0) 1582 745 700  
 Fax: +44 (0) 1582 745 745  
 E-mail: sales.admin@arjo.com

**USA**

Arjo Inc.  
 2349 W Lake Street Suite 250  
 US-Addison, IL 60101  
 Tel: +1 (630) 307-2756  
 Free: +1 (800) 323-1245  
 Fax: +1 (630) 307 6195  
 E-mail: us.info@arjo.com

**JAPAN**

Arjo Japan K.K.  
 東京都港区虎ノ門三丁目7番8号  
 ランディック第2 虎ノ門ビル9 階  
 Tel: +81 (0)3-6435-6401  
 Fax: +81 (0)3-6435-6402  
 E-mail: info.japan@arjo.com

At Arjo, we believe that empowering movement within healthcare environments is essential to quality care. Our products and solutions are designed to promote a safe and dignified experience through patient handling, medical beds, personal hygiene, disinfection, diagnostics, and the prevention of pressure injuries and venous thromboembolism. With over 6500 people worldwide and 65 years caring for patients and healthcare professionals, we are committed to driving healthier outcomes for people facing mobility challenges.



ArjoHuntleigh AB  
Hans Michelsensgatan 10  
211 20 Malmö, Sweden  
[www.arjo.com](http://www.arjo.com)

**arjo**

**CE**  
2797