

rehabhire & sales

YOUR
LEADING
HEALTHCARE
EQUIPMENT
PARTNER

ottobock.

Pointer

User Manual



1300 000 030 | rehabhire.com.au

YOUR
LEADING
HEALTHCARE
EQUIPMENT
PARTNER

Table of Contents

1	Foreword	5
2	Intended use	5
2.1	Indications for use.....	5
2.2	Qualification	5
3	Product description	6
3.1	Function	6
3.2	Product overview	6
4	Safety	7
4.1	Explanation of warning symbols	7
4.2	Safety instructions for use	7
4.3	Nameplate	9
5	Delivery	9
5.1	Scope of delivery	9
5.2	Storage	9
6	Preparation for use	9
6.1	Assembly	9
7	Use	10
7.1	Getting in and transferring	10
7.2	Settings.....	10
7.3	Seat	11
7.3.1	Optional: removing and fastening the seat cushion	11
7.3.2	Adjusting the seat upholstery	11
7.3.3	Adjusting the seating centre of gravity.....	12
7.3.4	Adjusting the seat height and seat inclination.....	12
7.4	Backrest	13
7.4.1	Fastening and removing the back pad	13
7.4.2	Adjusting the back upholstery	14
7.4.3	Adjusting the back angle.....	14
7.5	Side panels.....	15
7.5.1	Adjusting the height of the side panels.....	15
7.6	Legrest.....	15
7.6.1	Adjusting the legrest.....	15
7.6.2	Optional: Adjusting the lateral heel blocks.....	16
7.7	Rear wheels	17
7.7.1	Removing/attaching the rear wheels	17
7.7.2	Adjusting the quick-release axle	18
7.7.3	Adjusting the track width.....	18
7.7.4	Adjusting the push rings	19
7.7.5	Tensioning the spokes; adjusting the out-of-round	19
7.7.6	Retrofitting a spoke protector	19
7.8	Caster wheels and caster forks.....	20
7.8.1	Approach in case of stiffness	20
7.8.2	Replacing the caster wheels.....	21
7.9	Anti-tipper	21
7.9.1	Adjusting the anti-tipper height	21
7.9.2	Approach in case of stiffness	22
7.10	Protective pads.....	22
7.10.1	Removing/installing the protective pads	22

7.11	Disassembly and transport	23
7.12	Care	23
7.12.1	Cleaning	23
7.12.2	Disinfection	23
8	Maintenance and repair	23
8.1	Maintenance	23
8.1.1	Maintenance tasks	23
8.1.2	Further information on maintenance	24
8.2	Inspection	24
8.3	Repair	25
8.3.1	Inner tube, rim tape and tyre replacement	25
8.3.2	Replacing the side panels	26
8.3.3	Replacing the seat upholstery	27
8.3.4	Replacing the back upholstery	27
9	Disposal	28
10	Legal information	28
10.1	Liability	28
10.2	Warranty	28
10.3	Service life	28
10.4	Trademarks	28
11	Appendices	29
11.1	Technical data	29
11.2	Required tools	29
11.3	Torque values of the screw connections	29

1 Foreword

INFORMATION

Date of the last update: 2017-05-08

- ▶ Please read this document carefully before using the product.
- ▶ Follow the safety instructions to avoid injuries and damage to the product.
- ▶ Please contact the dealer if you have questions about the product (e.g. regarding the start-up, use, maintenance or unexpected operating behaviour). Please see the back for contact information.
- ▶ Please keep this document in a safe place.

INFORMATION

- ▶ New information regarding product safety and product recalls can be obtained from the Customer Care Center (CCC) at oa@ottobock.com or from the manufacturer's service department (see inside back cover or back page for addresses).
- ▶ You can request this document as a PDF file from the Customer Care Center (CCC) at oa@ottobock.com or from the manufacturer's service department (see inside back cover or back page for addresses). It is possible to increase the display size of the PDF document.
- ▶ For further questions about the instructions for use, please contact the dealer who issued the product to you.

Please read these instructions for use before you start using the product. Familiarise yourself with the handling, functions and use of the product before using it. Observe all safety information and instructions in order to prevent the possibility of injury. Store these instructions for use in a safe place for future reference.

Please note the following in particular:

- In case of questions or problems, please consult the dealer or the manufacturer's service (see inside back cover or back page for addresses).
- Service and repairs to the product may only be carried out by qualified personnel. If you have any problems, please contact your dealer. This ensures that any necessary repairs will be made exclusively with Ottobock spare parts.
- Note that excessive strain leads to increased wear of the components.
- Your product may differ from the models shown. In particular, not all the options described in these instructions for use will be installed on your product.
- The manufacturer reserves the right to make technical changes to the model described in these instructions for use.

2 Intended use

2.1 Indications for use

The wheelchair is intended exclusively for temporary use during physical exercise by a seated person participating in wheelchair sport in halls or sports facilities intended for this purpose which have hard, smooth floors, e.g. for basketball. The person using the wheelchair must be capable of reliably controlling it.

Any other or additional use is considered improper. Using the wheelchair in public transport, on a permanent basis, or outside of sporting activities is not permissible.

The product may only be combined with the options listed in these instructions for use. Ottobock assumes no liability for combinations with accessories from other manufacturers not included in the modular system.

The product may not be used by persons who are incapable of reliably controlling the wheelchair during training and match activities due to their mental or physical capacities.

2.2 Qualification

Inspections and repairs not described in these instructions for use may only be carried out by qualified personnel. Installation and adjustment work which may only be carried out by qualified personnel is indicated as such in the respective sections.

3 Product description

3.1 Function

This wheelchair was developed in cooperation with competitive athletes who have practical experience. Professional and recreational athletes are the primary user groups. The wheelchair can be used by youths and adults.

The wheelchair is designed as a configurable rigid-frame wheelchair. Each wheelchair is produced according to the ordered configuration. In addition, the following wheelchair features can be adjusted:

- Seat height
- Seat inclination
- Centre of gravity
- Back angle
- Legrest

The frame material and its processing ensure great stability and durability.

The rear wheels are attached to the frame with a quick-release axle (Ø 12 mm).

While the wheelchair can be used on solid ground both indoors and outdoors, it is intended in particular for use in indoor sports.

3.2 Product overview



1	Backrest with back upholstery	7	Caster wheel
2	Side panel	8	Anti-tipper wheel
3	Seat upholstery (optionally with seat cushion)	9	Rear wheel
4	Frame tubes, front	10	Push ring
5	Legrest with footplate	11	Frame tubes, rear
6	Bumper	12	Back stabiliser with padding

4 Safety

4.1 Explanation of warning symbols

⚠ WARNING Warning regarding possible serious risks of accident or injury.

⚠ CAUTION Warning regarding possible risks of accident or injury.

NOTICE Warning regarding possible technical damage.

4.2 Safety instructions for use

Hazards during preparation for use

⚠ WARNING

Independent modification of settings

Serious injuries to the user due to unallowable changes to the product

- ▶ In case of problems with the settings (unsatisfactory seating position, caster wheel wobble, etc.) please contact the dealer who issued the product to you or the manufacturer's service.

⚠ WARNING

Improper handling of packaging materials

Risk of suffocation due to neglect of the duty to supervise

- ▶ Packaging materials must be kept out of reach of children.

Risk of hand injuries

⚠ CAUTION

Pinching on components

Pinching, crushing due to lack of caution in danger areas

- ▶ Do not reach between the rear wheel and side panel when driving your wheelchair.
- ▶ Do not reach into the spokes of the rotating rear wheel.
- ▶ Avoid pinching parts of your body between the side or frame parts.

⚠ CAUTION

Heat development when braking with push rings

Burns due to insufficient hand protection

- ▶ Wear wheelchair gloves when travelling at high speeds.

Hazards while driving

⚠ CAUTION

Lack of driving experience

Tipping over, falling due to errors in handling the product

- ▶ Practise on level, open ground first.
- ▶ Learn with the support of an assistant how the wheelchair reacts to changes in the centre of gravity.

⚠ CAUTION

Driving on inclines or ramps

Tipping over, falling due to uncontrolled product movement

- ▶ Please note that the wheelchair does not have a wheel lock. Only drive on inclines or ramps with the active support of another person.

Hazards when overcoming obstacles

⚠ WARNING

Incorrect lifting

Tipping over, falling of the user due to lifting on components that come loose or are not intended for lifting

- ▶ Only lift the product on permanently welded components (e.g. main frame).
- ▶ Do not lift the product on components installed with screw connections or add-on components.

Hazard in case of broken skin

⚠ CAUTION

Prolonged contact with broken skin

Reddening of the skin or pressure points due to contamination with germs or incorrectly adapted seat cushion

- ▶ Check before using the product that the skin is not broken in areas subject to prolonged pressure (e.g., buttocks, back and rear side of the thighs).
- ▶ In case of problems please contact the dealer who issued the product to you or the manufacturer's service.
- ▶ No liability is assumed for injuries caused by the use of the product with broken skin.

Hazards due to fire, heat and cold

⚠ CAUTION

Extreme temperatures

Hypothermia or burns through contact with components, failure of components

- ▶ Do not expose the product to any extreme temperatures (e.g. direct sunlight, extreme cold).

Hazards due to improper use of the product

⚠ WARNING

Overloading

Severe injuries if the wheelchair tips over due to overloading, damage to the product

- ▶ Do not exceed the maximum load capacity (see the nameplate and section "Technical data").
- ▶ Please note that certain options and add-on components will reduce the remaining load capacity.

⚠ WARNING

Exceeding the service life

Serious injuries due to failure to observe the manufacturer's requirements

- ▶ Using the product beyond the specified expected service life (see Seite 28) leads to increased residual risk and should only take place subject to the due diligence and deliberations of qualified personnel.
- ▶ If the service life is reached, the user should contact the dealer or the manufacturer's service (see inside rear cover or back page for address). Here the user can obtain information about known risks and the current options for refurbishing the product.

NOTICE

Use under incorrect environmental conditions

Damage to product due to abrasion

- ▶ Avoid sand or other particles that may damage the wheel bearings.
- ▶ Only use the product in sports halls or sports facilities intended for this purpose which have hard, smooth floors.

4.3 Nameplate

Label	Meaning
 <p>The nameplate can be found on the frame under the seat</p>	A Type designation
	B Article number
	C Maximum load capacity (see section "Technical data")
	D Manufacturer information, address, country of origin
	E Serial number / manufacturing date*
	F European Article Number / Global Trade Item Number
	G Read the instructions for use before using the product.

*YYYY = year of manufacture; WW = week of manufacture; PP = production site; XXXX = sequential production number

5 Delivery

5.1 Scope of delivery

The wheelchair is delivered preassembled and with the rear wheels removed packed in a crate.

The scope of delivery includes:

- Preassembled wheelchair, including 2 side panels and 1 back pad
- 2 rear wheels with 1 quick-release axle each
- Options according to the order
- Instructions for use

5.2 Storage

The wheelchair packaging should be saved in case transportation is subsequently required. The wheelchair must be stored in a dry place. An ambient temperature between -10 °C and +40 °C must be maintained.

Tyres contain chemical substances that can react with other chemical substances (such as cleaning agents, acids, etc.).

6 Preparation for use

6.1 Assembly

CAUTION

Failure to verify readiness for use before putting into operation

Tipping, falling due to incorrect adjustment or installation

- ▶ Before you start using the wheelchair for the first time check the chosen wheelchair settings with the support of an assistant.
- ▶ After every assembly, check for proper mounting of the rear wheels. The quick-release axles must be securely locked in the receiver bushings.
- ▶ Pay particular attention to the stability against tipping and free running of the rear wheels.
- ▶ Check the tyre pressure. The correct tyre pressure is printed on the sidewall. Ensure that the pressure is the same in both tyres.

The wheelchair is preassembled at delivery (see Fig. 2).

It only takes a few simple steps to prepare the wheelchair for use:

- 1) Attach the rear wheels to the receiver bushings (see Seite 17).
- 2) **Optional:** Fit the seat cushion. The seat cushion is secured against sliding by being pressed on to the hook-and-loop fastener (see Seite 11).



7 Use

7.1 Getting in and transferring

⚠ CAUTION

Incorrect handling when getting in

Falling, tipping due to incorrect handling

- ▶ Always get into the wheelchair from the front or from the side if possible.
- ▶ Please note that the wheelchair does not have a wheel lock. Before getting into/out of the wheelchair, always secure it against rolling away.

To get into the wheelchair, the side panels or frame tubes can be used as supports.

7.2 Settings

⚠ WARNING

Incorrect settings

Risk of falling, tipping over or improper user posture due to incorrect settings

- ▶ Settings may only be changed by qualified personnel unless otherwise prescribed.
- ▶ Before testing setting changes with the user seated, all hook-and-loop connections must be firmly fastened and all screw connections must be firmly tightened.
- ▶ Check the product for safety and functionality after changing the settings.

⚠ CAUTION

Unsecured screw connections

Pinching, crushing, tipping over, falling of user due to assembly errors

- ▶ After all adjusting/readjusting work, retighten the mounting screws/nuts firmly. Observe any torque settings which may be specified.
- ▶ Any time you loosen a screw connection with thread lock, replace it with a new screw connection with thread lock or secure the old screw connection with medium strength thread locker (e.g. Loctite® 241).

⚠ CAUTION

Missing cover caps on screw connections

Blows, cuts on sharp ends of screw connections

- ▶ Cover caps must be removed for installation tasks on screw connections. Reinstall the cover caps on the ends of the screw connections after all installation tasks.

⚠ CAUTION**Improper use of self-locking nuts**

Tipping, falling over of the user due to screw connections coming loose

- ▶ Always replace self-locking nuts with new self-locking nuts after disassembly.

Adjustments to match the concrete physical and mental condition of the user should always be made in the user's presence.

All parts of the product should be cleaned thoroughly before adjustments are made.

Please note the following instructions when carrying out any adjustment:

- Adjust the wheelchair such that the seat bottom is horizontal or tilted to the rear.
- Adjust the centre of gravity such that the user can push the rear wheels as effectively as possible.
- Adjust the height of the side panels such that their upper edge is as parallel to the rear wheels as possible.
- Adjust the wheelchair such that the front frame tubes do not protrude beyond the bumper.

Concrete settings (e.g. seat and back upholstery etc.) are described in the following sections with the respective components.

The tools required for adjustments and maintenance tasks as well as the torque values for screw connections are listed in the section "Technical data" (see Seite 29 ff.).

7.3 Seat

⚠ WARNING**Seat cushion and back pad may ignite**

Burns due to user error

- ▶ The seat and backrest upholstery as well as padding fulfil the requirements for flame resistance according to ISO 8191-2 and DIN EN 1021-2. However, they may still ignite if fire is handled improperly or negligently.
- ▶ Keep away from all ignition sources, especially lit cigarettes.

NOTICE**Wear of the seat and back upholstery**

Loss of functionality due to unallowable continued use

- ▶ Replace the seat and back upholstery promptly in case of damage.

The seat cushion and the seat upholstery ensure pressure relief during use of the wheelchair. They can be adjusted according to the needs of the user.

7.3.1 Optional: removing and fastening the seat cushion

The seat cushion can be removed for cleaning.

- 1) Remove the seat cushion from the seat pad.
- 2) **After cleaning (see Seite 23):** Fit the seat cushion on the seat pad. The seat cushion is secured against sliding by being pressed on to the hook-and-loop fastener.

7.3.2 Adjusting the seat upholstery

The seat upholstery is attached to the frame tubes by 2 upholstery bars and is tensioned on one side with a hook-and-loop closure on the underside.

- 1) **Optional:** Remove the seat cushion from the seat pad.
- 2) Loosen the screw connections on the upholstery bars (see Fig. 3, item 1).
INFORMATION: Loosen the screw connections only until the seat upholstery underneath can be moved.
- 3) Open the hook-and-loop closure along the upholstery bar (see Fig. 4).
- 4) Adjust the tension of the seat pad to the weight and anatomical condition of the user and securely fasten the hook-and-loop closure along the upholstery bar.
INFORMATION: The hook-and-loop closure must completely overlap itself.
- 5) Firmly tighten the screw connections on the upholstery bars (see Fig. 3, item 1).
- 6) **Optional:** Attach the seat cushion to the seat pad.

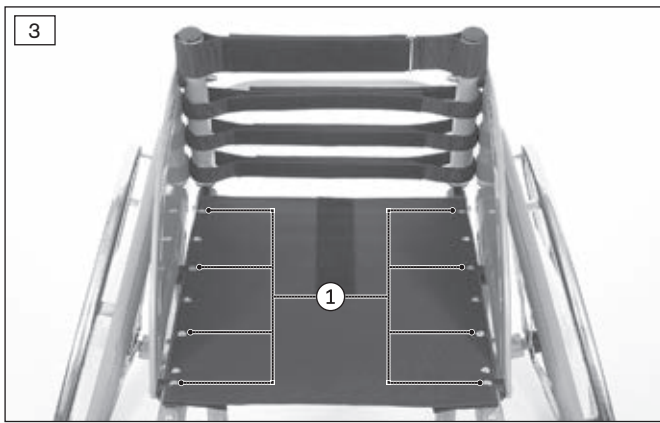

7.3.3 Adjusting the seating centre of gravity

INFORMATION

The assembly tasks described below may only be carried out by qualified personnel.

The seating centre of gravity can be subsequently adjusted using the perforated plates under the side panels.

- 1) Slightly loosen the screw connections on the joints of both front frame tubes (see Fig. 5, item 1).
- 2) Loosen and remove the screw connections on both perforated plates (see Fig. 6).
- 3) Pull the seat to the desired position.
- 4) Insert the screw connections into the appropriate slots on both perforated plates and firmly tighten them (see Fig. 6).
- 5) Firmly tighten the screw connections on the joints of both front frame tubes (see Fig. 5, item 1).

CAUTION! After changing the seating centre of gravity, the seat inclination must also be readjusted (see Seite 12). The seat bottom must be horizontal or tilted back.

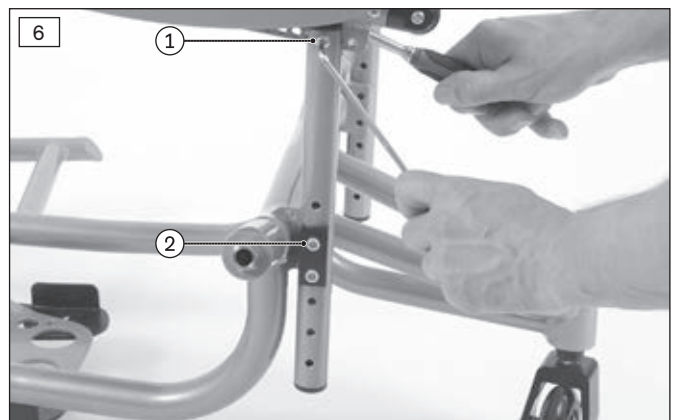
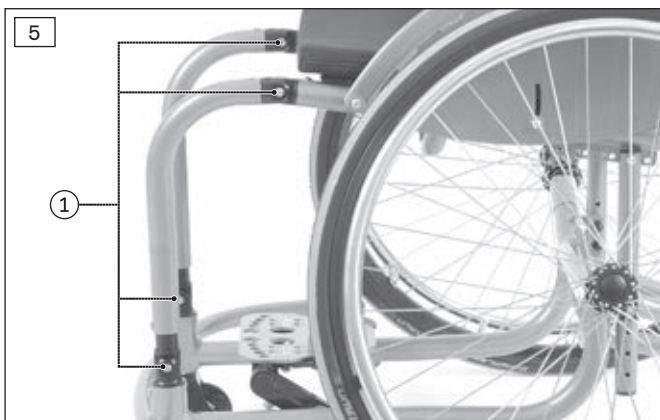

7.3.4 Adjusting the seat height and seat inclination

INFORMATION

The assembly tasks described below may only be carried out by qualified personnel.

The seat height can be subsequently adjusted with the front and rear frame tubes. The front and rear seat height can be adjusted separately. The seat inclination setting depends on the combination of the front and rear seat height. In order to adjust the seat height without changing the seat inclination, the front and rear seat height must be evenly adjusted together.

Adjusting the rear seat height

- 1) Slightly loosen the screw connections on the joints of both front frame tubes (see Fig. 5, item 1).
- 2) Slightly loosen the screw connections on both perforated plates (see Fig. 6, item 1).
- 3) Loosen and remove the screw connections on both rear frame tubes (see Fig. 6, item 2).
- 4) Pull the seat with the rear frame tubes to the desired height and inclination.

- 5) Insert the screw connections into the appropriate slots on the rear frame tubes and firmly tighten them (see Fig. 6, item 2).
- 6) Firmly tighten the screw connections on the joints of both front frame tubes (see Fig. 5, item 1).
- 7) Firmly tighten the screw connection on both perforated plates (see Fig. 6, item 1).

CAUTION! The front and rear seat height must be coordinated with one another. The seat bottom must be horizontal or tilted back.

Adjusting the front seat height

- 1) Slightly loosen the screw connections on the joints of both front frame tubes (see Fig. 5, item 1).
- 2) Slightly loosen the screw connections on both perforated plates (see Fig. 6, item 1).
- 3) Loosen and remove the screw connections on both front frame tubes (see Fig. 7, item 1).
- 4) Pull the seat with the front frame tubes to the desired height and inclination.
- 5) Insert the screw connections into the appropriate slots on the rear frame tubes and firmly tighten them (see Fig. 7, item 1).
- 6) Firmly tighten the screw connections on the joints of both front frame tubes (see Fig. 5, item 1).
- 7) Firmly tighten the screw connection on both perforated plates (see Fig. 6, item 1).

CAUTION! The front and rear seat height must be coordinated with one another. The seat bottom must be horizontal or tilted back.

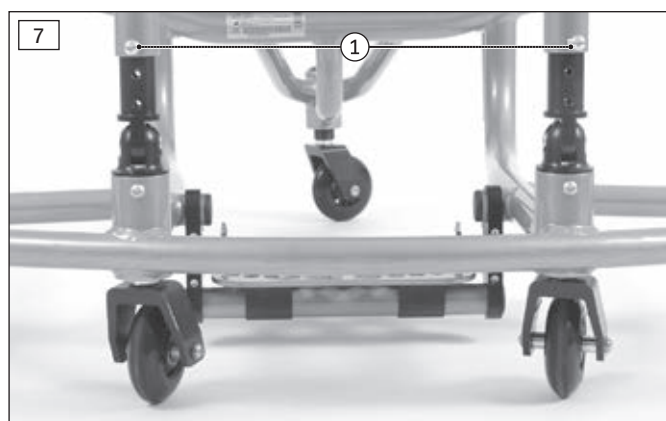

7.4 Backrest

⚠ WARNING

Seat cushion and back pad may ignite

Burns due to user error

- ▶ The seat and backrest upholstery as well as padding fulfil the requirements for flame resistance according to ISO 8191-2 and DIN EN 1021-2. However, they may still ignite if fire is handled improperly or negligently.
- ▶ Keep away from all ignition sources, especially lit cigarettes.

NOTICE

Wear of the seat and back upholstery

Loss of functionality due to unallowable continued use

- ▶ Replace the seat and back upholstery promptly in case of damage.

The back pad and back upholstery ensure pressure relief during use of the wheelchair. They can be adjusted according to the needs of the user.

7.4.1 Fastening and removing the back pad

The back pad can be removed for cleaning.

- 1) **Optional:** Remove the seat cushion from the seat pad.
- 2) Pull the lower end of the back pad off the hook-and-loop fastener on the seat pad.
- 3) Pull the back pad up and off the back upholstery (see Fig. 8).
- 4) **After cleaning (see Seite 23):** Put the back pad back onto the back upholstery. Position the seam of the back pad exactly over the upper upholstery strap.

- 5) Pull the back pad down and attach it to the hook-and-loop fastener on the back upholstery.
- 6) Attach the lower end of the back pad to the hook-and-loop fastener on the seat pad.
INFORMATION: This prevents sliding and protects against draughts.
- 7) **Optional:** Fasten the seat cushion to the hook-and-loop fastener on the seat pad.

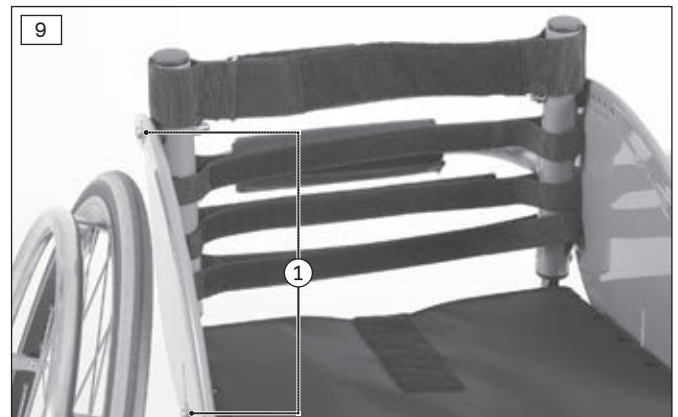

7.4.2 Adjusting the back upholstery

The back upholstery is attached to the frame tubes with hook-and-loop straps.

- 1) Fold up the back pad.
- 2) Loosen the screw connections on both side panels (see Fig. 9, item 1).
- 3) Open and loosen the hook-and-loop straps one after the other.
- 4) Seat and position the user in the wheelchair.
- 5) From the bottom to the top, adjust the tension of the hook-and-loop straps to the weight and anatomical condition of the user and fasten the straps.

INFORMATION: The two ends of the hook-and-loop strap have to overlap by at least 100 mm in each case.

INFORMATION: Adjust the respective lower hook-and-loop straps somewhat tighter.

INFORMATION: Deviating adjustments may be required in specific cases.

- 6) Firmly tighten the screw connections on both side panels.
- 7) Pull the back pad down and attach it to the hook-and-loop fastener on the back upholstery.

7.4.3 Adjusting the back angle

The angle of the backrest can be subsequently adjusted with the side panel.

- 1) Slightly loosen the screw connections on the joints of the backrest (see Fig. 10, item 1).
- 2) Loosen the screw connections on both side panels (see Fig. 10, item 2).
- 3) Loosen and remove the screw connections between both side panels and the backrest (see Fig. 10, item 3).
- 4) Pivot the backrest to the desired angle (see Fig. 11).
- 5) Insert the screw connections into the appropriate slots on the side panels and firmly tighten them (see Fig. 11, item 3).
- 6) Firmly tighten all screw connections on the side panels (see Fig. 11, item 2).
- 7) Firmly tighten the screw connections on the joints of the backrest (see Fig. 11, item 1).

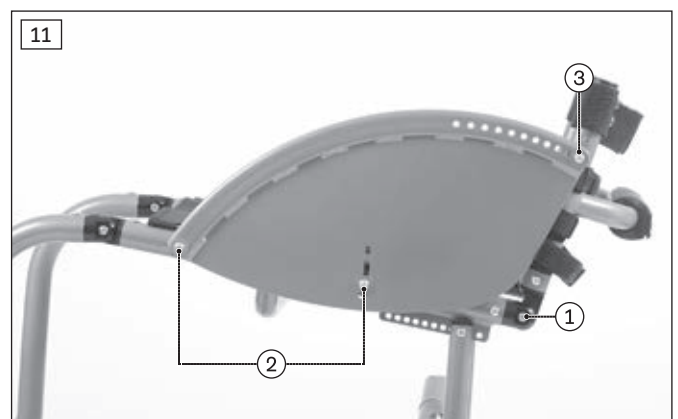
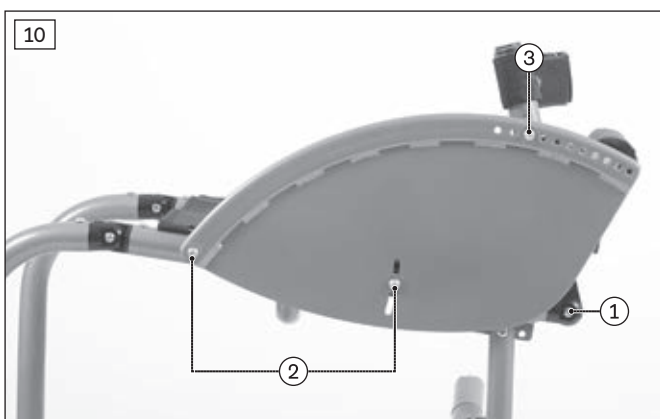

7.5 Side panels

⚠ CAUTION

Pinching at the side panels

Pinching, crushing due to lack of caution in danger areas

- ▶ Avoid pinching parts of your body between the side or frame parts.

The side panels protect the user from dirt and in case of a collision during competitive sports.

7.5.1 Adjusting the height of the side panels

The height of the side panels can be adapted to the requirements of the user.

- 1) Loosen the screw connections on the side panel (see Fig. 12, item 1).
- 2) Loosen and remove the screw connection between the side panel and backrest.
- 3) Pivot the side panel to the desired height (see Fig. 13).
- 4) Insert the screw connection into the appropriate slot on the backrest and firmly tighten it.
- 5) Firmly tighten all screw connections on the side panel (see Fig. 12, item 1).

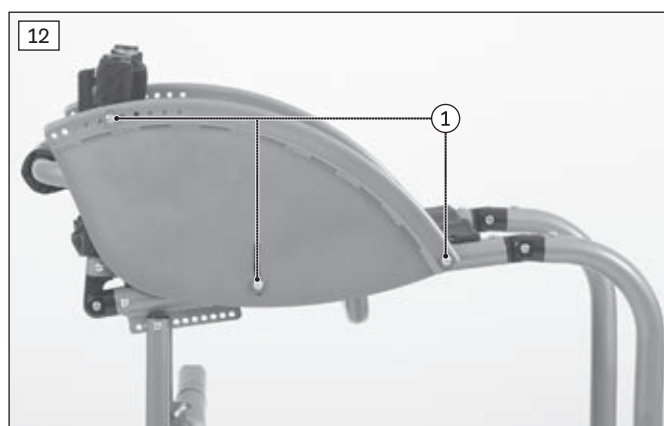

7.6 Legrest

The user's feet can be placed on the legrest.

An adjustable footplate is mounted on the wheelchair (see Fig. 14, item 1).

Depending on the order, the footplate can be equipped with adjustable lateral heel blocks (see Fig. 14, item 2).

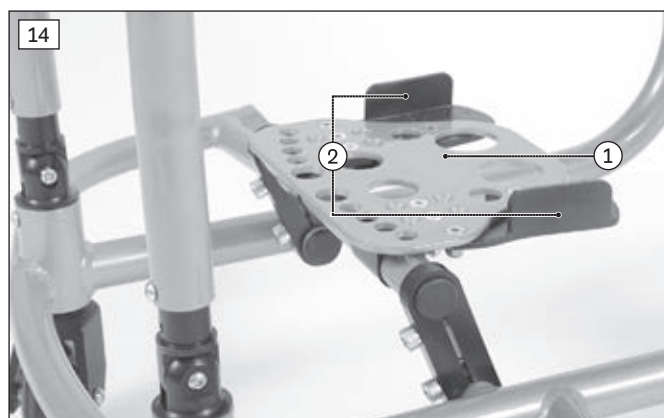

7.6.1 Adjusting the legrest

NOTICE

Improper adjustment of the legrest

Collision, damage to the legrest due to incorrect adjustment

- ▶ When adjusting the legrest, always make sure there is sufficient clearance measuring at least 20 mm between the legrest and the floor.

7.6.1.1 Adjusting the lower leg length and the plate angle

After adapting the seat height and the seat inclination, the lower leg length and the plate angle can be adjusted on the legrest. The legrest angle setting should be chosen so that the ankle is in a relaxed, comfortable position.

- 1) Loosen the screw connections on both clamp brackets of the legrest (see Fig. 15).
- 2) Pivot the legrest to the desired height and desired angle.
- 3) Firmly tighten the screw connections on both clamp brackets of the legrest (see Fig. 15).



7.6.1.2 Adjusting the footplate position

The footplate can be moved in 3 levels to the front or rear.

- 1) Loosen and remove the 4 screw connections on the footplate (see Fig. 16, item 1).
- 2) Move the footplate to the desired position on one of the 3 levels.

INFORMATION: If the legrest is equipped with lateral heel blocks, the adjustment range of the footplate may be restricted.

- 3) Insert the 4 screw connections into the appropriate slots on the footplate and firmly tighten them (see Fig. 16).

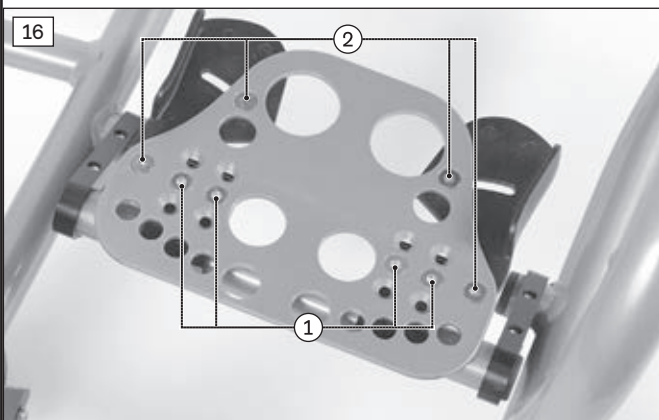

Expanding the adjustment range

If a larger adjustment range is required, the footplate can be turned by 180°.

- 1) Loosen the screw connections on both clamp brackets of the legrest (see Fig. 15).
- 2) Pivot the legrest to the top position.
- 3) Move the footplate with the axle to the side and out of the clamp brackets (see Fig. 17).
- 4) Insert the footplate with the axle turned 180° into both clamp brackets and centre it.
- 5) Pivot the legrest to the desired height and desired angle.
- 6) Firmly tighten the screw connections on both clamp brackets of the legrest.

7.6.2 Optional: Adjusting the lateral heel blocks

The lateral heel blocks support the secure placement of the feet and can be adapted to the anatomical condition of the user.

- 1) Loosen the screw connections on both lateral heel blocks (see Fig. 16, item 2).
- 2) Pivot the lateral heel blocks to the desired position.

INFORMATION: Depending on the position of the footplate, the adjustment range of the lateral heel blocks may be restricted.

- 3) Firmly tighten the screw connections on both lateral heel blocks (see Fig. 16, item 2).

7.7 Rear wheels

⚠ CAUTION

Incorrect fitting of the rear wheels

Tipping, falling over of the user due to wheels coming off

- ▶ After each assembly, verify the proper fit of the rear wheels.
- ▶ The quick-release axles must be firmly locked in the wheel attachment.

⚠ CAUTION

Reaching into exposed drive parts

Crushing, pinching due to incorrect handling

- ▶ Do not reach between the rear wheel and side panel when driving your wheelchair.
- ▶ Do not reach into the spokes of the rotating rear wheel.

⚠ CAUTION

Defective tyres

Accidents/falling due to poor traction, reduced braking force or lack of manoeuvrability

- ▶ Maintain sufficient tyre pressure. The correct tyre pressure is printed on the tyre sidewall.
- ▶ Ensure that the pressure is the same in both tyres.
- ▶ Replace damaged tyres promptly and in pairs.

⚠ CAUTION

Heat development when braking with push rings

Burns due to insufficient hand protection

- ▶ Wear wheelchair gloves when travelling at high speeds.

The wheelchair is moved, steered, braked and stopped with the help of the push rings on the rear wheels.

7.7.1 Removing/attaching the rear wheels

⚠ CAUTION

Incorrect removal/attachment of the wheels

Tipping, falling due to incorrect installation

- ▶ For changing wheels, set the wheelchair onto a solid surface.
- ▶ To change the wheels, secure the wheelchair against tipping over or rolling away.
- ▶ If the rear wheel does not lock securely or has too much sideways play, contact the qualified personnel promptly.

- 1) Grip the area between the spokes near the hub with your fingers.
- 2) Use your thumb to press the push-button on the quick-release axle (see Fig. 18).
- 3) Pull off/push on the rear wheel. The quick-release axles must not be removable after releasing the push-button.

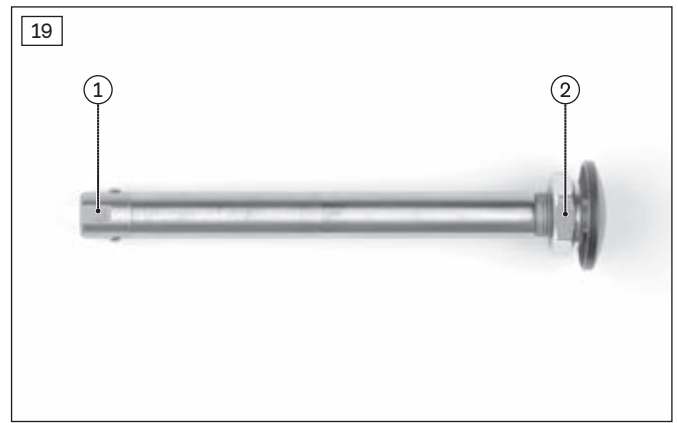

7.7.2 Adjusting the quick-release axle

INFORMATION

The assembly tasks described below may only be carried out by qualified personnel.

The quick-release axle should be set so the wheel is correctly engaged, with no play on the axle.

- 1) Hold the tip of the quick-release axle with a wrench (see Fig. 19, item 1).
- 2) Adjust the play by turning the nut on the end of the quick-release axle (see Fig. 19, item 2) in or out.

7.7.3 Adjusting the track width

INFORMATION

The assembly tasks described below may only be carried out by qualified personnel.

The track width of the rear wheels can be subsequently adjusted within a narrow range. This makes it possible to increase or decrease the distance between the rear wheel and side panel.

- 1) Remove the rear wheel (see Seite 17).
- 2) Loosen the counter nut on the quick-release axle mounting (see Fig. 20, item 1).
- 3) Turn the fitting in or out (see Fig. 20, item 2).

INFORMATION: Adjust the quick-release axle mounting evenly on the left and right side.

- 4) Firmly tighten the counter nut on the quick-release axle mounting (see Fig. 20, item 1).
- 5) Attach the rear wheel (see Seite 17).

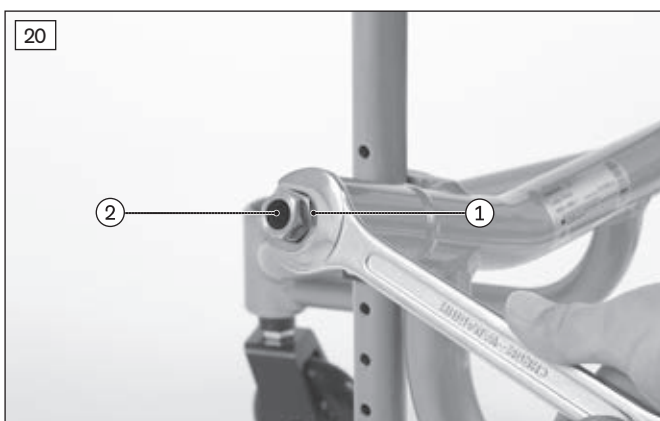

7.7.4 Adjusting the push rings

INFORMATION

The assembly tasks described below may only be carried out by qualified personnel.

All push rings can be mounted with a narrow or wide clearance between them and the rear wheel.

- 1) Completely remove the tyre (see Fig. 22).

INFORMATION: Take care not to damage the rim or the inner tube.

- 2) Loosen and remove the push ring screw connection from the rim.
- 3) Tightly screw the push rings onto the rim in narrow or wide installation position (see Fig. 21).

INFORMATION: Do not remove the rubber lining around the push ring brackets.

- 4) Completely reinstall the tyre.



7.7.5 Tensioning the spokes; adjusting the out-of-round

INFORMATION

The assembly tasks described below may only be carried out by qualified personnel.

Tensioning the spokes

- 1) Completely remove the tyre (see Fig. 22).

INFORMATION: Take care not to damage the rim or the inner tube.

- 2) Check the spoke tension by shaking/moving the spokes.
- 3) If necessary, carefully adjust the tension of the spokes with a spoke tensioner.
- 4) Completely reinstall the tyre.

Adjusting the out-of-round

Adjusting the out-of-round by a maximum of **1 mm** requires special instruments and technical knowledge. The adjustment should be performed in a bicycle specialist workshop.

7.7.6 Retrofitting a spoke protector

INFORMATION

The assembly tasks described below may only be carried out by qualified personnel.

The spoke protector serves to protect the spokes and prevents reaching into the rotating rear wheels.

Snap fasteners (attachment nipples) are used for installation.

- 1) Remove the rear wheels.
- 2) Position the spoke protector on the rim so that it is centred and you can see a spoke beneath each of the six bore holes.
- 3) From the outside, press in the attachment nipples e.g. with a hammer handle until you hear them lock in place on the spokes (see Fig. 23).

INFORMATION: Screw connections are required for installation in some versions (see Fig. 24).



7.8 Caster wheels and caster forks

The combination of caster wheels and caster forks ensures the ability to hold a straight line and navigate bends securely. Sport casters (Ø 3") are installed on the wheelchair.



7.8.1 Approach in case of stiffness

In case of stiffness, the caster forks or caster wheel axles should be cleaned and oiled.

Oiling the caster forks

INFORMATION

The assembly tasks described below may only be carried out by qualified personnel.

- 1) Loosen and remove the screw connections on both caster housings (see Fig. 26, item 1).
- 2) Pull the frame joints up and out of both caster housings (see Fig. 26).
- 3) Remove dirt from the caster fork around the hexagon nut (see Fig. 27, item 1).
- 4) Add a few drops of thin, resin-free oil to the housing (sewing machine oil).
- 5) Re-insert the frame joints in both caster housings (see Fig. 26).
- 6) Insert the screw connections into both caster housings and firmly tighten them (see Fig. 26, item 1).

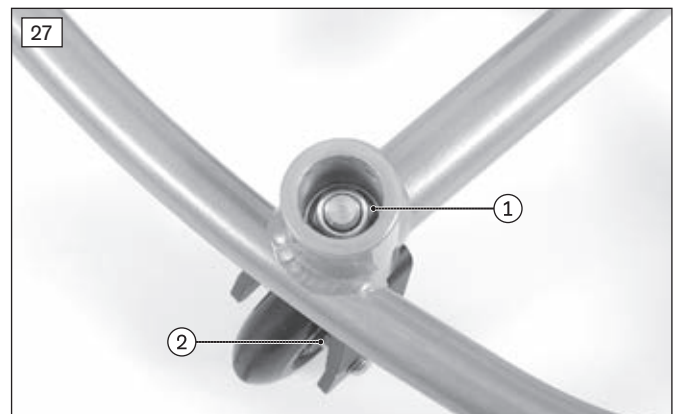
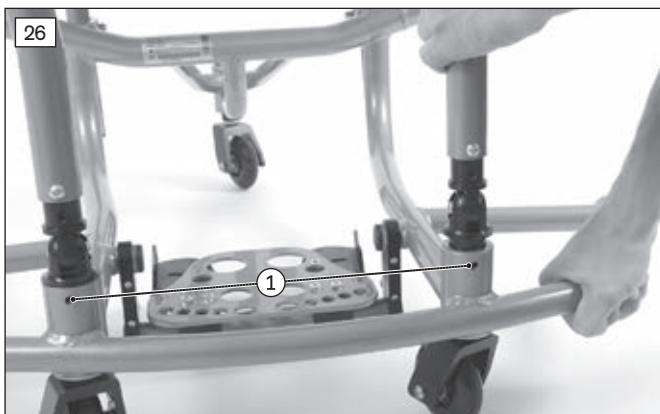

Oiling the caster axle

- 1) Remove dirt from the caster axle (e.g. hairs).
- 2) Lubricate the caster axle between the caster wheel and caster fork with a few drops of thin, resin-free oil (sewing machine oil) (see Fig. 27, item 2).

7.8.2 Replacing the caster wheels

INFORMATION

The assembly tasks described below may only be carried out by qualified personnel.

The caster wheels can be replaced in case of wear.

- 1) Loosen the caster wheel axle screw connection (see Fig. 28, item 1).
- 2) Remove the caster wheel axle/spacers (see Fig. 28, item 2).
- 3) Remove and replace the caster wheels.
- 4) Install the caster wheels together with the spacers. Tighten the caster wheel axle screw connection to **8 Nm**.

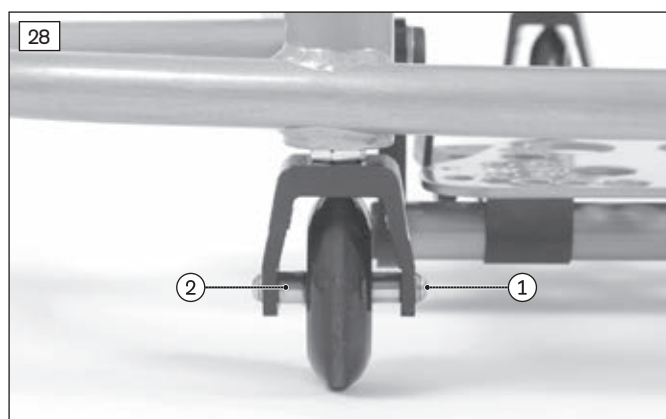

7.9 Anti-tipper

⚠ WARNING

Incorrectly adjusted anti-tipper

Risk of falling as a result of incorrectly adjusted anti-tipper

- ▶ The anti-tipper may only be adjusted by qualified personnel.

An anti-tipper wheel is mounted on the wheelchair (see Fig. 29).

An anti-tipper pad protects the anti-tipper housing.

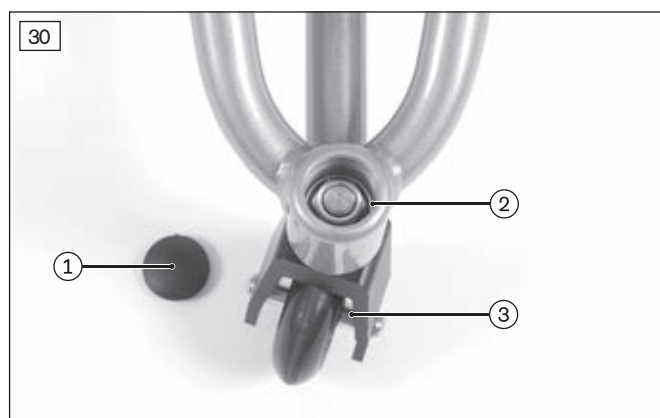
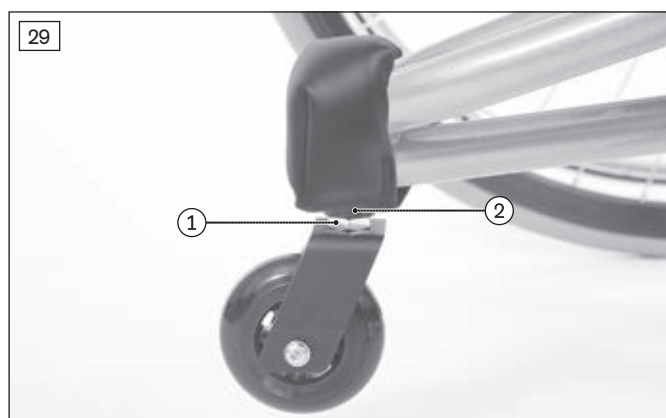

7.9.1 Adjusting the anti-tipper height

INFORMATION

The assembly tasks described below may only be carried out by qualified personnel.

The anti-tipper wheel is height-adjustable within a narrow range.

- 1) Open the hook-and-loop closure of the protective pad and remove the protective pad (see Fig. 32).
- 2) Use a screwdriver to pry open the cap on the housing (see Fig. 30, item 1).
- 3) Secure the hexagon nut on the wheel fork with a small wrench (see Fig. 29, item 1).
- 4) Loosen the hexagon nut in the housing with a socket wrench (see Fig. 30, item 2).
- 5) Pull the swivel axle down and out of the housing.
- 6) Place a maximum of 2 spacer washers on the wheel fork to modify the ground clearance (see Fig. 29, item 2).
- 7) Insert the swivel axle.
- 8) Insert the hexagon nut into the housing and firmly tighten it (see Fig. 30, item 2).
- 9) Close the housing.
- 10) Attach the protective pad and fasten the hook-and-loop closure (see Fig. 32).

7.9.2 Approach in case of stiffness

In case of stiffness, the anti-tipper wheel axle should be cleaned and oiled.

- 1) Remove dirt from the axle (e.g. hairs).
- 2) Lubricate the axle between the wheel and wheel fork with a few drops of thin, resin-free oil (sewing machine oil) (see Fig. 30, item 3).

7.10 Protective pads

For the protection of users, some components of the wheelchair can be equipped with protective pads:

- Pad for back stabiliser (see Fig. 31)
- Anti-tipper pad (see Fig. 32)
- **Optional:** frame pad (see Fig. 33)



7.10.1 Removing/installing the protective pads

The protective pads can be removed for cleaning.

- 1) Open the hook-and-loop closures and remove the protective pads (illustration see previous section).
- 2) **After cleaning (see Seite 23):** Secure the protective pads on the wheelchair again, respectively with the hook-and-loop fasteners to prevent slipping.

7.11 Disassembly and transport

The wheelchair must be prepared for transport in a passenger vehicle.

- 1) Remove the rear wheels (see page 18).

INFORMATION: The rear wheels can be safely stowed in a bag (optional) for transport.

- 2) Place the disassembled wheelchair and components safely in the vehicle.
- 3) Securely reattach the rear wheels during reassembly.

7.12 Care

7.12.1 Cleaning

- 1) Clean the padding and upholstery with warm water and a mild detergent.
- 2) Remove any spots with a sponge or a soft brush.
- 3) Rinse with clear water and let the components dry.

Important information on cleaning

- Do not use any aggressive cleaners, solvents or hard brushes, etc.
- Clean plastic parts, frame parts and the chassis and wheels with a mild cleaner and a damp cloth. Dry thoroughly afterwards.
- Do not immerse in water. Components are not machine-washable.
- To care for aluminium or chrome, use conventional aluminium or chrome care and cleaning products.
- Do not spray the product with a pressure washer.

7.12.2 Disinfection

- 1) Thoroughly clean the pads before disinfecting.
- 2) Wipe all parts of the wheelchair with a disinfectant.

Important information about disinfecting

- If the product is used by more than one person, using a conventional disinfectant is required.
- Only use colourless water-based disinfectants. Observe the instructions for use provided by the manufacturer.

8 Maintenance and repair

8.1 Maintenance

- The function of the product should be checked before each use.
- The product should not be used if defects are noted. This applies in particular in case of altered driving characteristics as well as problems with the user's seating position or the stability of the seat. Inform the qualified personnel promptly for the rectification of defects.
- This also applies if loose, worn, bent or damaged components, cracks in the frame or broken frame components are identified.
- Some maintenance tasks within a defined scope can be completed directly by the user (see the sections "Maintenance tasks" and "Further maintenance information").
- The manufacturer also recommends a regular inspection every **12 months** by the dealer who issued the product to you or the manufacturer's service (see the section "Inspection").
- Failure to maintain the product can lead to serious or life-threatening injury to the user of the product.
- Servicing and repairs may only be carried out by qualified personnel or the manufacturer. This will ensure that only Ottobock spare parts are used for repairs.

8.1.1 Maintenance tasks

The functions described below must be checked by the user at the specified intervals:

When	Inspection task	Note
Before each use	Check all components with screw connections for firm fit	Check the following in particular: Legrest attachment; function of the quick-release axles.
	Check the tyre pressure High-pressure tyres: 8.0 bar (116 psi) Indoor sport tyres: 11.0 bar (160 psi) 16.0 bar (232 psi)	Use a pressure gauge. If none is available: use the "thumb pressure method".
	Check the tyre tread	Perform a visual inspection. If the tyre tread is worn or the tyre is damaged, contact the qualified personnel.
	Check the back tubes and frame tubes for damage	In case of deformation or the formation of cracks in the area of the welding seams, contact the qualified personnel promptly. Risk of accident!
Every 8 weeks (depending on strain)	Oil components (with a few drops of oil): all axles on the wheelchair	Remove old oil residue from components before oiling. Make sure that oil does not pollute the environment.
	Check screw connections for firm fit	
Every 6 months (depending on frequency of use)	Check cleanliness and overall condition	Observe the information in the section "Care".

8.1.2 Further information on maintenance

- Bolted connections must be periodically checked for tightness, especially during the initial period of use or after adjustments have been made to the wheelchair. If a screw connection loosens repeatedly, contact the dealer who issued the product to you or the manufacturer's service promptly.
- Hair and dirt particles generally accumulate between the caster wheel and fork. This can restrict the caster wheels from rotating smoothly over time. Remove the caster wheel and thoroughly clean the fork and caster wheel using a mild household cleaner.
- The rear wheels are equipped with a quick-release axle system as standard equipment. To keep this system operational, ensure that no dirt adheres to the quick-release axle or receiver bushing. Periodically lubricate the quick-release axle very lightly with thin, resin-free oil (sewing machine oil).
- The spokes should be lightly lubricated with petroleum jelly on occasion.
- If the wheelchair becomes wet, it should be rubbed dry again.

8.2 Inspection

- For reasons of product safety, an annual inspection is to be performed on this wheelchair type according to the list below.
- Under more severe conditions – e.g. in case of increased strain – the user should have an interim inspection of the frame and chassis performed.
- Product inspections may only be carried out by qualified personnel.

Inspection task		Check off after completion
Preparation	Remove the seat cushion and back pad	
	Clean the product	
Visual inspection	Check the frame and joints for damage and corrosion	
	Check welding seams for the formation of cracks	
	Check wear parts (e.g. tyres, bearings) for wear and dirt	
	Check add-on components and accessories for damage and corrosion	

Inspection task		Check off after completion
General inspection	Check all screw connections for firm fit	
	Check the attachment of all add-on components	
	Check hook-and-loop closures, add-on components and accessories	
Rear wheels	Check that wheel mounts are securely fastened	
	Check that wheels rotate freely and without axial runout	
	Check the driving characteristics of the wheelchair	
	Check the spoke tension	
	Check push rings for damage	
Caster wheels	Check that the fork is seated in the adapter without play	
	Check that wheels rotate freely and without axial runout	
	Check that the mounting nuts are tight	
Legrest	Check for functionality and firm fit	
	Check legrest for damage	
Padding/straps	Ensure padding is in perfect condition	
	Check adjustment straps for signs of wear	
Tyres	Check tyre pressure (see tyre sidewall)	
	Check for sufficient tread depth (min. 1 mm)	
	Check for damage	
Oil/grease	Oil pivot points and bearing points of movable components	
	Grease spokes	
Final inspection	Check the general functionality of the mechanical adjustment mechanisms	
	Driving test	

8.3 Repair

8.3.1 Inner tube, rim tape and tyre replacement

⚠ CAUTION

Improper tyre replacement

Injuries to the user due to incorrect installation, product damage

- ▶ No person is permitted to sit in the wheelchair during tyre replacement.
- ▶ Before removing a wheel, support the product so it cannot tip over.
- ▶ Always replace the tyres in pairs. Two differently worn tyres affect the directional stability of the wheelchair.

INFORMATION

Tubeless TUFO indoor sport tyres can be ordered as an option for this wheelchair type. They have to be replaced entirely in case of damage.

Repairing flat tyres requires only the necessary tools and users may change tyres themselves if they wish.

Removal and preparing for installation

- 1) Carefully remove the tyre from the rim using appropriate tools.
INFORMATION: Take care not to damage the rim or the inner tube.
- 2) Unscrew the valve nut from the valve and remove the tube.
- 3) Repair the tube according to the directions in the repair kit or replace it with a new tube.
- 4) Before fitting the tyre again, inspect the rim bed and tyre inner wall for foreign objects. This could have caused the puncture.
- 5) Before installing the tube, check that the rim band is in proper condition. The rim band protects the tube from being damaged by the ends of the spokes.



Replacing the rim band (only when necessary)

- 1) If the rim band needs to be replaced, remove it from the rim.
- 2) Install the new rim band on the inside of the rim, making sure the valve opening is in the right position.
- 3) Glue the rim band in place if this is intended. Ensure that all spoke ends are covered.

Installing the tube and tyre

- 1) Behind the valve, push one side of the tyre over the edge of the rim.
- 2) Slightly inflate the tube until it starts to assume its round shape.
- 3) Unscrew the valve nut from the tube and push the valve through the valve opening in the rim.
- 4) Insert the tube into the tyre.
- 5) Mount the other side of the tyre on the rim, starting from the position across the valve. Ensure that the tube is not pinched between the tyre and rim during this process.



Inflating the tube

- 1) Ensure that the valve is positioned perpendicularly for proper positioning of the tube and tyre in the region of the valve.
- 2) Firmly screw on the valve nut.
- 3) Inflate the tube so that the tyre can still be pressed in easily with your thumb.
INFORMATION: If the circumferential lines on the two sides of the tyre are both at an even distance from the rim, the tyre is centred. If not, let some air out and realign the tyre.
- 4) Inflate the tube to the maximum pressure specified by the tyre manufacturer (see information printed on the tyre sidewall).
- 5) Firmly screw the valve cap onto the valve.

8.3.2 Replacing the side panels

Damaged side panels can be replaced.

- 1) Remove the rear wheels (see Seite 17).
- 2) Loosen and remove the screw connections on both side panels.
- 3) Replace the side panels and mount them to the frame and backrest with 3 screw connections and half-shell spacers each (see Fig. 38). Face the flat surfaces of the side panels inwards as you do so.

INFORMATION: One of the 3 screws is shorter. Insert the short screw into the slotted hole of the side panel (see Fig. 39).

- 4) Firmly tighten all screw connections on the side panels.
- 5) Attach the rear wheels to the receiver bushings (see Seite 17).

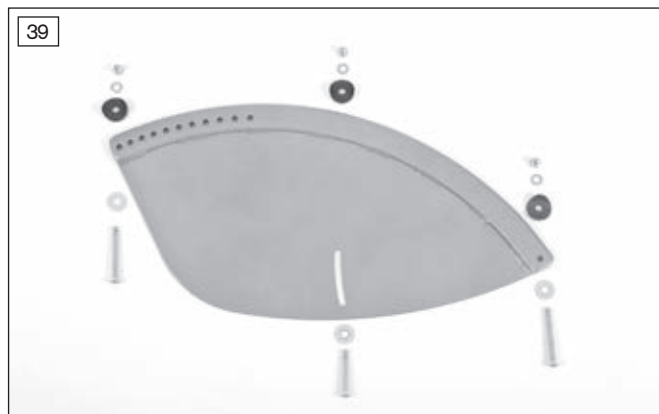

8.3.3 Replacing the seat upholstery

Damaged or worn seat upholstery can be replaced.

- 1) Remove the seat cushion from the seat pad.
- 2) Loosen and remove the screw connections on both upholstery bars (see Fig. 40, item 1).
- 3) Remove the seat upholstery with the upholstery bars.
- 4) Replace the seat upholstery and insert the upholstery bars into the seat upholstery.
- 5) Install the seat upholstery with the upholstery bars on the frame tubes.

INFORMATION: Align the seat pad with the centre hook-and-loop strip towards the backrest (see Fig. 40).

- 6) Adjust the seat upholstery and firmly tighten the screw connections (see Seite 11).
- 7) Attach the seat cushion to the seat pad.

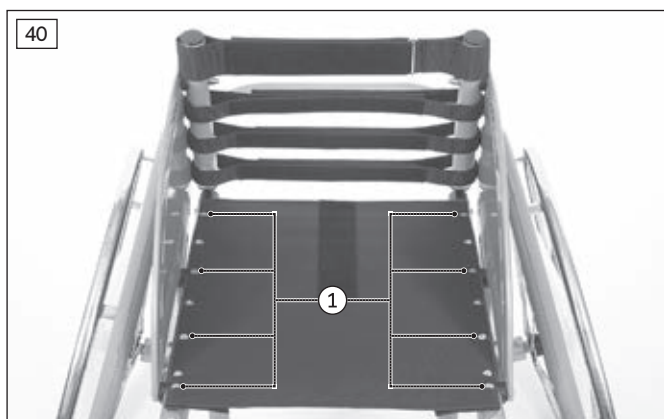

8.3.4 Replacing the back upholstery

Damaged or worn back upholstery can be replaced.

- 1) Remove the back pad from the back upholstery.
- 2) Loosen the screw connections on both side panels (see Fig. 42, item 1).
- 3) Open and replace the hook-and-loop straps on the back upholstery.

INFORMATION: To replace the top hook-and-loop strap, 2 screw connections on both the left and right sides of the backrest must be loosened (see Fig. 43, item 1).

- 4) Adjust the back upholstery (see Seite 14).
- 5) Firmly tighten all screw connections on the backrest and side panels.
- 6) Attach the back pad to the back upholstery.

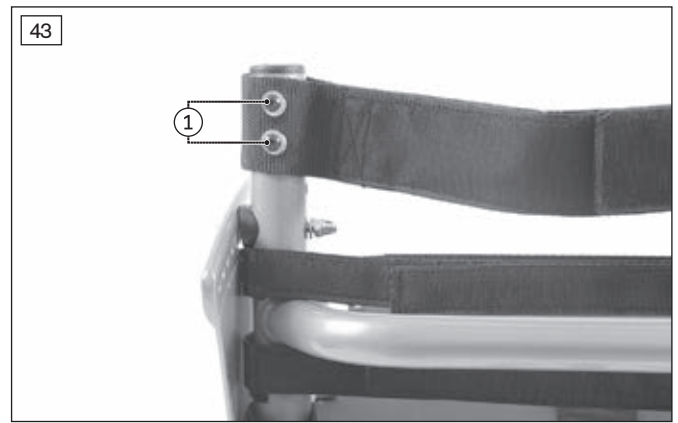
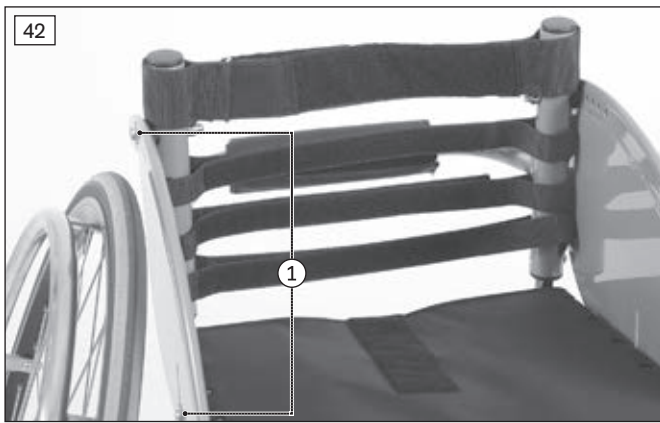

9 Disposal

Return the product to the dealer who issued the product to you for disposal.

All components of the product must be disposed of properly in accordance with the respective national environmental regulations.

10 Legal information

All legal conditions are subject to the respective national laws of the country of use and may vary accordingly.

10.1 Liability

The manufacturer will only assume liability if the product is used in accordance with the descriptions and instructions provided in this document. The manufacturer will not assume liability for damage caused by disregard of this document, particularly due to improper use or unauthorised modification of the product.

10.2 Warranty

Further information on the warranty terms and conditions is available from the dealer who issued the product to you or the manufacturer's service (see inside back cover for addresses).

10.3 Service life

Expected service life: **4 years**.

The design, manufacturing and requirements for the intended use of the product are based on the expected service life. These also include the requirements for maintenance, ensuring effectiveness and the safety of the product.

Using the product beyond the specified expected service life leads to increased residual risk and should only take place subject to the due diligence and deliberations of qualified personnel.

If the service life is reached, the user should contact the dealer or the manufacturer's service (see inside rear cover or back page for address). Here the user can obtain information about known risks and the current options for refurbishing the product.

10.4 Trademarks

All product names mentioned in this document are subject without restriction to the respective applicable trademark laws and are the property of their respective owners.

All brands, trade names or company names may be registered trademarks and are the property of the respective owners.

Should trademarks used in this document fail to be explicitly identified as such, this does not justify the conclusion that the denotation in question is free of third-party rights.

11 Appendices

11.1 Technical data

INFORMATION

All information in the following tables refers to the respective custom-made model. The dimensional tolerance is ± 15 mm, $\pm 2^\circ$.

Dimensions

Frame length [mm]	430; 480; 530
Lower leg length [mm]	340–470
Minimum rear seat height [mm]	370
Maximum front seat height [mm]	530
Back height [mm]	250; 300; 350; 400

Wheels

Caster wheel \varnothing (sport caster) [mm]	76 (3")
Rear wheel \varnothing [mm]	610 (24"); 660 (26")
Rear wheel axle \varnothing (quick-release axle) [mm]	12
Tyre pressure [bar]	
High-pressure tyres	8
Indoor sport tyres	11
Tubeless indoor sport tyres	16

Temperatures

Ambient temperature [°C]	-20 to +40
Storage temperature [°C]	-10 to +40

Weights

Maximum load capacity (maximum user weight) [kg]	120
--	-----

11.2 Required tools

The following tools are required for adjustments and maintenance work:

- Allen wrenches in sizes 3, 4, 5, 6
- Hexagon socket wrench in size 19
- Small open-end wrench in size 19
- Ring and open-end wrenches in sizes 8, 10, 13, 20 and 24
- Screwdriver (blade width: 2.5 mm)

11.3 Torque values of the screw connections

Unless otherwise specified, screw connections are tightened with the following torque values:

- Thread diameter M4: 3 Nm
- Thread diameter M5: 5 Nm
- Thread diameter M6: 10 Nm
- Thread diameter M8: 25 Nm
- Thread diameter M10: 50 Nm
- Thread diameter M12: 85 Nm

rehabhire & sales

1 300 000 030

320 Lorimer Street Port Melbourne
contact@rehabhire.com.au
rehabhire.com.au

rehabhire & sales **REPAIRS AND SERVICE**

REGULAR MAINTENANCE OR REPAIRS

1 300 000 030

Unit 6 | 52 Wirraway Drive Port Melbourne
service@rehabhire.com.au
rehabhire.com.au/repairs-and-service

rehabinstallation

CAN MODIFY EVERY ROOM IN YOUR HOME TO
ENSURE IT IS ACCESSIBLE, SAFE, AND COMFORTABLE

1 300 000 030

320 Lorimer Street Port Melbourne
contact@rehabinstallation.com.au
rehabinstallation.com.au



Registered NDIS Provider