

rehabhire & sales



YOUR
LEADING
HEALTHCARE
EQUIPMENT
PARTNER

J800
BY **SCOOBY®**

User Manual

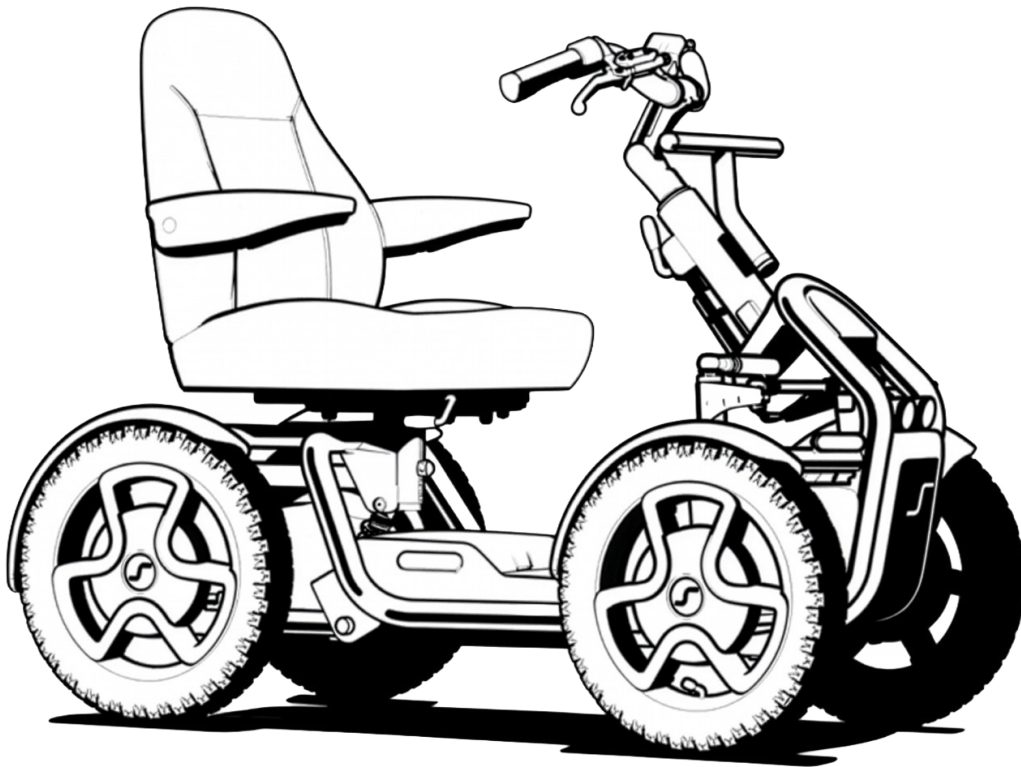

1300 000 030 | rehabhire.com.au

YOUR
LEADING
HEALTHCARE
EQUIPMENT
PARTNER

Contents

1.0 User information	4
1.1 This user manual	4
1.2 For further information	4
1.3 Symbols used in this manual	5
2.0 Safety	6
2.1 Symbols and labels used on the product	6
2.2 Safety: Temperature	6
2.3 Safety: Moving parts	6
2.4 Safety: Electromagnetic radiation	7
2.5 Safety: Choking hazard	7
2.6 Ramps for transporting the scooter	7
2.7 Safety: Lifting the scooter	7
3.0 Intended use of the scooter	8
3.1 Area of application: The user	8
3.2 Area of application: The user environment	9
4.0 Setting up the scooter	10
4.1 Seat height	10
4.2 Seat depth	10
4.3 Back angle	10
4.4 Armrest angle	10
4.5 Tiller adjustment	11
4.6 Handlebar height	11
4.7 Control system programme	11
4.8 Available OPTIONS	11
4.8.1 Controls	11
4.8.2 Tyres	12
4.8.3 Accessory bar	12
4.8.4 Mounting points for universal mobility scooter accessories	12
4.8.5 Sunrise Intelligence – Scooter Connectivity (not available for all markets)	12
4.8.6 Lap strap / seating positioning belt	13
5.0 Using the scooter	14
5.1 Checking scooter before use	14
5.2 Making a transfer	15
5.3 Driving the scooter	15
5.4 Curves	16
5.5 Braking & Emergency Stop	16
5.6 Driving on a slope	17
5.7 Obstacles & kerbs	17
5.8 Pushing the scooter	18
5.9 Using Near Water	18
6.0 Controls	19
6.1 Changing Settings	20
6.2 Switch On/Off	21
6.2.1 Switch on with key	21
6.2.2 Switch on with password	21
6.2.3 Switch off	21
6.3 Lights	21
6.3.1 Headlights, daylights and the rear lights	21
6.3.2 Indicators	21
6.3.3 Hazard lights	22
6.4 Driving	22
6.4.1 Driving forward	22
6.4.2 Reversing	22
6.4.3 Cruise Control	22
6.5 Braking	22
6.5.1 Emergency Braking Using the Hand Brake	22
6.5.2 Emergency Braking Using The Stop Button	22
7.0 Batteries, charging and range	23
7.1 Batteries	23
7.2 Charging batteries	23
7.2.1 Charging Socket	23
7.3 Lithium-ion battery below 3°C	25
7.4 The range of your vehicle	25
7.5 Battery warranty	26
7.6 Battery Removal	26
7.7 Disconnecting batteries for air transport	26
8.0 Transport	27
8.1 Transportation in vehicles	27
8.2 Using your scooter on the train	27
8.3 Other Transport requirements	27
9.0 Maintenance & cleaning	28
9.1 Maintenance	28
9.2 Tyre maintenance and pressures	30
9.2.1 Tyre pressure	30
9.2.2 Tyre wear	30
9.3 Tyre Replacement Instructions	30
9.4 Maintenance and Inspection Schedule	31
9.5 Lighting maintenance	32
9.6 Cleaning and disinfection	32
9.7 Medium to long term storage	33
9.8 Storage temperature & humidity	33
10.0 Trouble shooting	34
11.0 Disposal	35
12.0 Specification Sheets (EN 12184 & ISO 7176-15) ...	36
13.0 Warranty	38
14.0 Name Plate	39

1.0 User information

Thank you for choosing a Sunrise Medical scooter. Sunrise Medical's high-quality mobility products are designed to enhance independence and make your everyday life easier.

As a part of our ongoing product improvement initiative, Sunrise Medical reserves the right to change specifications and design without notice.

However, any changes to the information provided for existing users shall be clearly communicated if they are safety critical.

Further, not all features and options offered are compatible with all configurations of the scooter.

All dimensions are approximate and may be subject to change.

The intended lifetime of the scooter is 6 years. Please **DO NOT** use or fit any 3rd party components to the scooter unless they are officially approved by Sunrise Medical.

1.1 This user manual

This user manual will help you to use and maintain your scooter safely.

Do not use your scooter until this entire manual has been read and understood!

1.2 For further information

Please contact your local, authorized Sunrise Medical dealer if you have any questions regarding the use, maintenance or safety of your scooter. In case there is no authorized dealer in your area or you have any questions, contact Sunrise Medical either in writing or by telephone.

For information about product safety notices and product recalls, go to www.SunriseMedical.co.uk

In the event of a safety-related product change being made by Sunrise Medical, all customers will be contacted and informed of this.

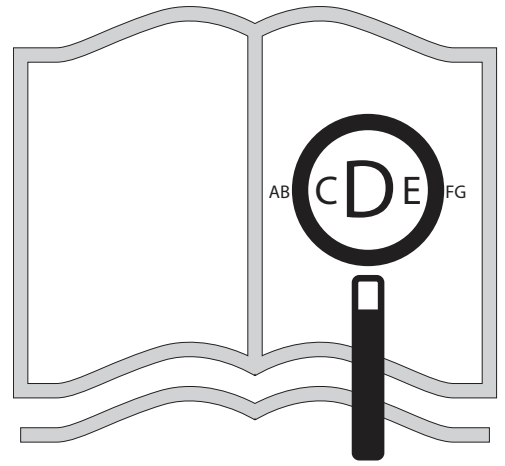



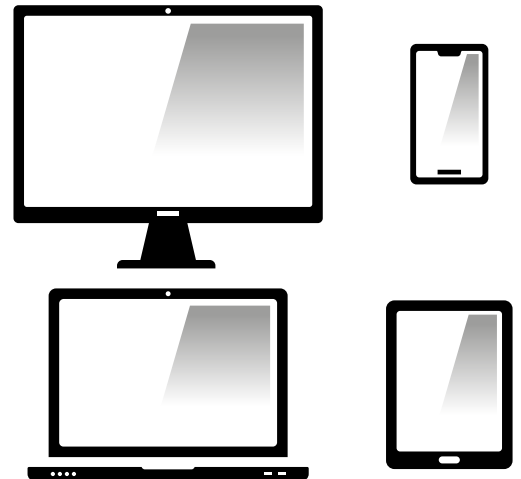

If you are visually impaired, this document can be viewed in PDF format at www.SunriseMedical.co.uk





or alternatively is available on request in large text.



1.3 Symbols used in this manual

 DANGER!	Potential risk of injury or serious injury or death
 WARNING!	Potential risk of injury
 CAUTION!	Potential damage to equipment
NOTE!	General advice or best practice
	Reference To Additional Documentation

 As the manufacturer, SCOozy B.V., declares that this product conforms to the Medical Device Regulation (2017/745).

 As the Authorised Representative, MEDPATH LIMITED, declares that the product conforms to the UK Medical Devices Regulation 2002 No. 618.

NOTE:

General user advice

Not following these instructions may result in physical injury, damage to the product or damage to the environment!

Notice to the user and/or patient: Any serious incident that has occurred in relation to the device should be reported to the manufacturer and the competent authority of the Member State in which the user and/or patient is established.

Medical Device Combinations (UKCA)

It may be possible to combine this medical device with one or more other medical device or another product. Information on which combinations are possible can be found at www.sunrisemedical.co.uk. All combinations listed have been validated.

Medical Device Combinations

It may be possible to combine this Medical device with one or more other medical device or another product. Information on which combinations are possible can be found at www.Sunrisemedical.co.uk. All combinations listed have been validated to meet the General Safety and Performance Requirements, Annex I Nr. 14.1 of the Medical Device Regulation 2017/745.

Guidance on the combination, such as mounting, can be found at www.SunriseMedical.co.uk.

2.0 Safety

Follow the instructions carefully next to these warning symbols! Not paying careful attention to these instructions could result in physical injury or damage to the scooter or the environment. Wherever possible, safety information is provided in the relevant chapter.

2.1 Symbols and labels used on the product

The signs, symbols and instructions affixed to the scooter comprise part of the safety facilities. They must never be covered or removed. They must remain present and clearly legible throughout the entire lifespan of the scooter. Replace or repair all illegible or damaged signs, symbols and instructions immediately. Please contact your dealer for assistance.

Fig. 2.1 The freewheel sticker is located on top of the hood over the engine. 'Enable' indicates "the setting that the S800 can be moved freely, and 'disable' indicates the setting in which the S800 is ready to be electrically driven.

Fig. 2.2 Label on the gas spring to prevent body parts from getting trapped

Fig. 2.3 The serial number and information label

Fig. 2.4 The CE sticker is located on the frame under the steering column. All vehicles have a serial number plate showing the year of production and the serial number.

2.2 Safety: Temperature

WARNING!

- Avoid physical contact with the scooter's motors at all times. Motors are continuously in motion during use and can reach high temperatures. After use, the motors will cool down slowly. Physical contact could cause burns. Allow the motors after using at least 30 min. to cool down.
- If you do not use the scooter, ensure that it is not exposed to direct sunlight for lengthy periods of time. Certain parts of the scooter, such as the seat, the back and the armrests can become hot if they have been exposed to full sunlight for too long. This may cause burns or allergic reactions to the skin.
- Be aware that in extremely cold weather, exposed metal parts can present a freeze burn hazard, particularly if the hands are wet.

2.3 Safety: Moving parts (Fig.2.5)

DANGER!

A scooter has moving and rotating parts. Contact with moving parts may result in serious physical injury or damage to the scooter. Contact with the moving parts of the scooter should be avoided.

- Wheels
- Seat rotation lever
- Seat forward/backward positioning lever
- Tiller angle adjustment
- Folding the armrests away
- Operating the freewheel lever

Fig. 2.1



Fig. 2.2



Fig. 2.3



Fig. 2.4



Fig. 2.5

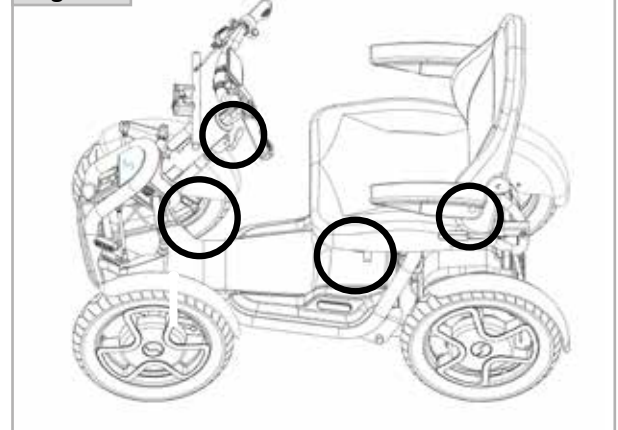

2.4 Safety: Electromagnetic radiation

CAUTION!

The standard version of your electric scooter has been tested on the applicable requirements with respect to electromagnetic radiation (EMC requirements) In spite of these tests:

It cannot be excluded that electromagnetic radiation may have an influence on the scooter. For example:

- mobile telephony
- large-scale medical apparatus
- other sources of electromagnetic radiation
- It cannot be excluded that the scooter may interfere with electromagnetic fields. For example:
 - shop doors
 - burglar alarm systems in shops
 - garage door openers

In the unlikely event that such problems do occur, we request that you notify your dealer immediately.

DANGER!

- When operating two-way radio, walkie-talkies, C.B., Amateur radio, public mobile radio and other powerful transmitting devices the scooter should be brought to a halt and turned off.
- The operation of cordless, mobile telephones and cell phones including hands-free devices is permitted but if abnormal operation of the scooter is encountered then the scooter must be brought immediately to a halt and turned off.

2.5 Safety: Choking hazard

DANGER!

This mobility aid uses small parts which under certain circumstances may present a choking hazard to young children.

2.6 Ramps for transporting the scooter

DANGER!

- When using a ramp, please ensure that it is able to take the combined weight of the scooter and yourself.
- If a ramp is being used to load a scooter into a vehicle, please ensure the ramp is properly secured to the vehicle.
- Always approach the ramp head-on and exercise caution.
- Please ensure the ramp is suitable for the product you are transporting.
- Maximum ramp angle = 10° (18%)
- Follow all the user instructions supplied with the ramp.
- Be aware that accessories attached to the scooter may affect the overall stability.

DANGER!

- Ensure that the user and all carers fully understand the lift manufacturer's instructions for using the passenger lift.
- Never exceed the lift manufacturer's recommended safe working load and load distribution guidance.
- Always turn off all power when you are on the lift. If you fail to do so, you may touch the throttle/controls by accident and cause your scooter to drive off the platform. Be aware that a roll-stop at the end of the platform may not prevent this.
- Always position the user securely in the scooter to help avoid falls while on the lift.
- Always ensure the scooter is in drive mode when using passenger lift (wheels locked not in freewheel mode).

2.7 Safety: Lifting the scooter

WARNING!

- Do not lift this scooter, seat or batteries by any parts that are removable, doing so may result in damage to the scooter or injury to the user.

3.0 Intended use of the scooter

General description

The Sterling S800 by Scoozy provides an easy shift from biking to a mobility scooter, with familiar handlebar controls, 18-inch wheels, advanced suspension, and a lithium battery. Built for stability and comfort on urban and nature trails, the S800 delivers a stylish and customizable mobility solution.

3.1 Area of application: The user

Scooters are exclusively for a user who may have difficulty walking distances or for periods of time, for their own personal use indoors and outdoors on (paved and unpaved) sidewalks, footpaths, cycle paths, forest paths and roads (if permitted by local traffic regulations).

Driving a scooter requires cognitive, physical and visual skills. The user must be able to estimate and correct the results of actions when operating the scooter.

The scooter cannot transport more than 1 person at a time. The maximum weight limit (including both the user and any weight of accessories fitted to the scooter) is 161kg.

For restrictions on user weight limit refer to technical specification, chapter 12.

The user must be informed of the contents of this user manual before driving the scooter. In addition, the user of the scooter must be given thorough instruction by a qualified specialist before he or she participates in traffic. The first sessions in the scooter should be practiced under supervision of a trainer/ advisor.

Indications

The varieties of fitting variants, as well as the modular design, mean that it can be used by those who cannot walk or have limited mobility because of:

- Paralysis
- Loss of extremity (leg amputation)
- Extremity defect/deformity
- Joint contractures/joint injuries
- Strokes and brain injuries
- Neurological disabilities
- Illnesses such as heart and circulation deficiencies, disturbance of equilibrium or cachexia as well as for elderly people who still have strength in the upper body.

Contraindications

The mobility scooter shall not be used in case where any of the following impair safe operation:

- Visual or other perception disorder
- Disorders of awareness or alertness
- Uncontrolled involuntary movements or imbalance that cannot be accommodated
- Unstable position in sitting
- Loss of both arms, if not supported by a caregiver
- Joint contracture or joint damage on both arms

Fig. 3.1

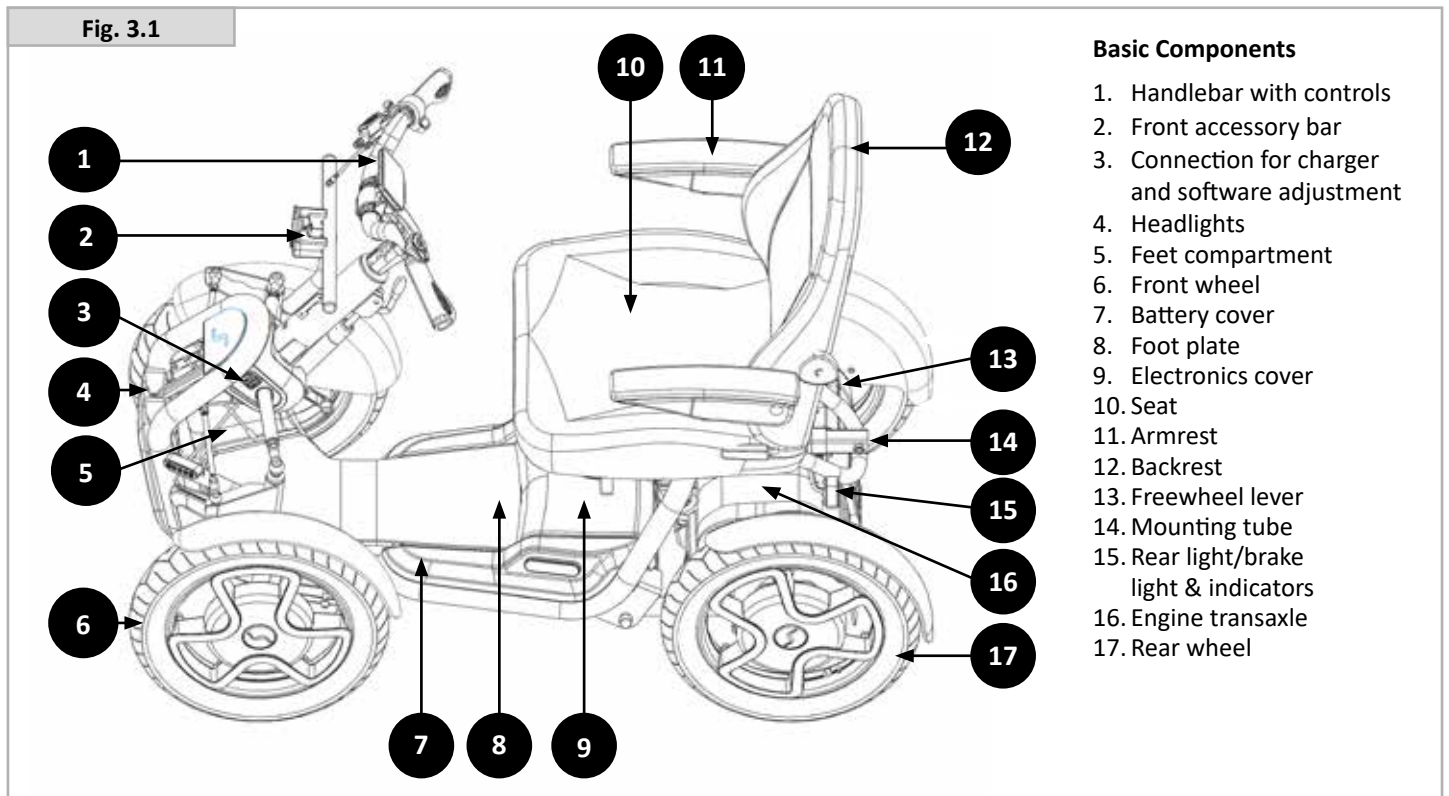

Basic Components

1. Handlebar with controls
2. Front accessory bar
3. Connection for charger and software adjustment
4. Headlights
5. Feet compartment
6. Front wheel
7. Battery cover
8. Foot plate
9. Electronics cover
10. Seat
11. Armrest
12. Backrest
13. Freewheel lever
14. Mounting tube
15. Rear light/brake light & indicators
16. Engine transaxle
17. Rear wheel

NOTE:

Please note that driving a mobility scooter requires sufficient cognitive, physical and visual skills. The user must be able to assess the effects of actions during the operation of the scooter and, if necessary, to correct them. These capabilities and the safe use of the additionally attached components cannot be assessed by Sunrise Medical as a manufacturer. We cannot accept any liability for any damage resulting from this.

Please refer to the operating instructions of the mobility scooter and the additionally mounted components. Instruct the user in the safe use of the scooter and the additionally mounted components. Inform users of specific warnings that need to be read, understood, and respected.

WARNING!

- If you are under the influence of substances (such as drugs, alcohol or medication) that can affect your ability to drive, you are not permitted to drive a scooter.
- Adequate vision is required to safely operate a scooter in the user situation concerned.
- Not more than one person at a time can be seated in the scooter.
- Do not allow children to ride in the scooter unsupervised.

CAUTION!

- The user of the scooter is at all times completely responsible for complying with the applicable local safety regulations and guidelines.

3.2 Area of application: The user environment

The S800 can be used as an EN12184: Type C mobility scooter. Class C Scooters are usually large in size, not necessarily intended for indoor use but capable of travelling longer distances and negotiating outdoor obstacles.

They are intended for use in public places and similar locations where there are pavements, pedestrian paths or floors that have hard and firm surfaces. The safe limit for slopes and obstacles shall be observed.

They may be used on the roads in compliance with local country traffic law.

The speed must be adapted to suit the environment.

WARNING!

- Drive carefully on slippery roads resulting from rain, ice or snow!
- You are required to turn on the lights in case of limited visibility.
- When driving at higher speeds you must be extra careful.
- Select a lower maximum speed indoors, on the pavement and in pedestrian areas.
- Do not drive off high obstacles.
- Do not attach a weight to the scooter without the approval of a qualified specialist. This may negatively affect the stability of the product.

CAUTION!

- Prevent the scooter from coming into contact with seawater: seawater is caustic and may damage the scooter.
- Prevent the scooter from coming into contact with sand: sand can permeate into the moving parts of the scooter, causing extensive wear on these parts.
- Do not use the scooter if temperatures are below -25°C or above +50°C.
- Do not push and/or tow any objects with the scooter.
- Do not drive through puddles of water.

4.0 Setting up the scooter

The S800 can be adjusted according to the specific needs of the user. Pre-settings are carried out once, the first time the scooter is going to be used. They must be executed by a qualified specialist, unless explicitly stated otherwise.

4.1 Seat height (Fig. 4.1)

The seat is attached to the seat post with a nut-and-bolt connection. If needed, your dealer or supplier can adjust the seat height by 2 or 4 centimeters.

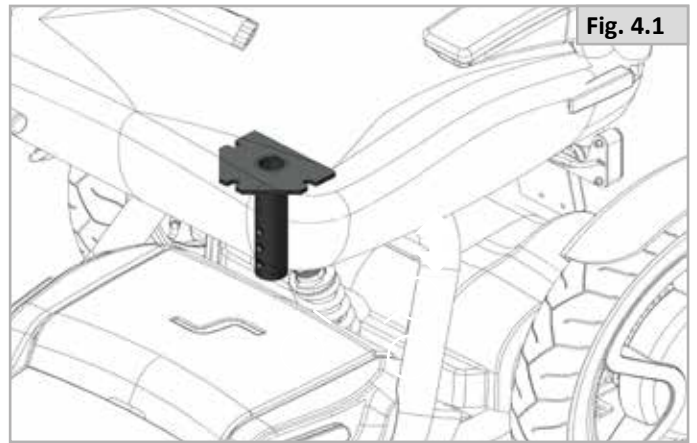

4.2 Seat depth (Fig. 4.2)

⚠ WARNING!

- When you move the chair using the sliding sledge, your centre of gravity shifts. Be aware of this, especially when driving up a slope.
- Do not adjust the seat position while driving as serious injury could happen if you lose control.

1. Lift the lever (A) on the right side of the seat.
2. Slide the seat forward or backwards.
3. Release the lever and check that it clicks into the lock.

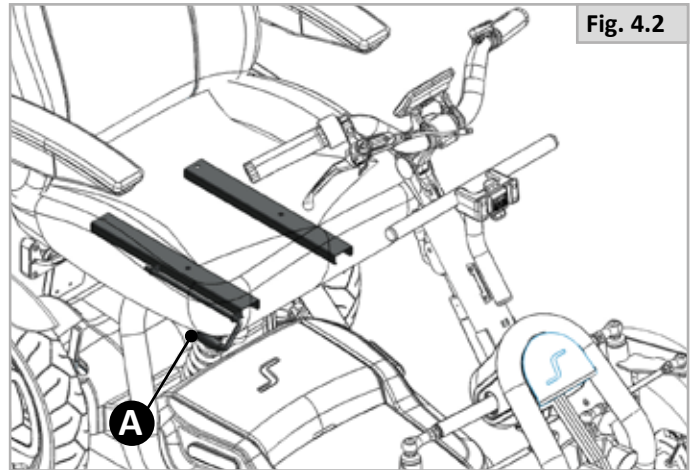

4.3 Back angle (Fig. 4.3)

⚠ WARNING!

- When adjusting the back angle, be careful not to get your fingers caught.
- Only adjust the backrest when you are sitting in the chair.

1. Sit down on the seat.
2. Lift the lever (A) on the left-hand side at the back of the seat.
3. Use your upper body to push the backrest backwards into the right position, or:
4. Bend your upper body forward to let the backrest move forward automatically.
5. Release the lever and check whether the backrest clicks into the lock.



4.4 Armrest angle (Fig. 4.4)

Turn the adjustment wheel (A) on the bottom of the armrest to raise or lower the armrest to the desired angle.

⚠ CAUTION!

The position of the armrests changes when the backrest is adjusted.

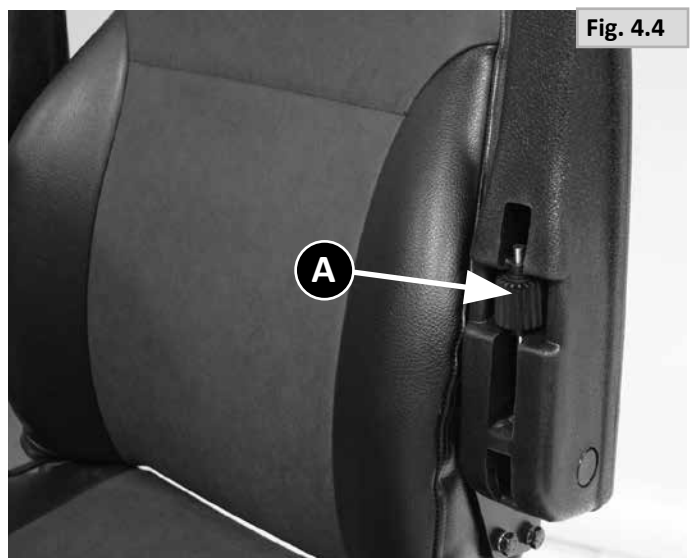

4.5 Tiller adjustment (Fig. 4.5)

DANGER!

- Do not adjust the angle of the steering column while driving. A gas spring allows the handlebars to move forward automatically.
- Do not adjust the tiller while the scooter is being driven as serious injury could happen if you lose control.
- Do not use the tiller adjustment handle to hold or carry items such as bags etc.
- Ensure fingers or other items are not around the area of the lower tiller when making adjustments. Serious injury could happen due to entrapment.

1. Sit down on the seat.
2. Pull the lever (A) towards you.
3. Pull the steering column towards you or push it away until the desired position is reached.
4. Release the lever (A) to lock the steering column in the desired position, and check that it is securely clamped.

4.6 Handlebar height (Fig. 4.6)

You can change the height of the handlebar by moving the stem higher or lower.

1. Press the button on the left side of the stem.
2. Pull the quick-release lever up and adjust the handlebar to the desired position.
3. Lock the handlebars again by pressing the quick-release lever downwards and check whether the handlebars are properly clamped again.

4.7 Control system programme

This scooter is equipped with a control system that can be programmed by adjusting settings within the system. This is a specialized job that needs training and can only be adjusted with professional software. The end user is not allowed to adjust these settings.

DANGER!

- Only leave the scooter programming to technicians trained by Scoozy or Sunrise Medical.
- Incorrect controller settings can lead to dangerous driving behaviour and even cause damage or injury.
- Only change the settings if you have mastered driving with the S800.

4.8 Available OPTIONS

Consult your dealer for advice on the versions and the purchase and installation of options and accessories.

4.8.1 Controls (Fig. 4.7)

The S800 comes equipped with a vertical thumb throttle (A), control buttons (B), and a handbrake/parking brake. The standard setup has the vertical thumb throttle and handbrake on the right, with the buttons on the left. Your dealer can adjust the control positions upon request.

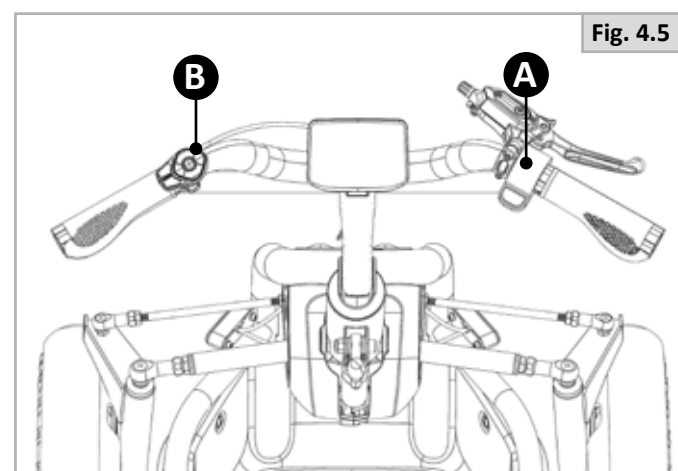
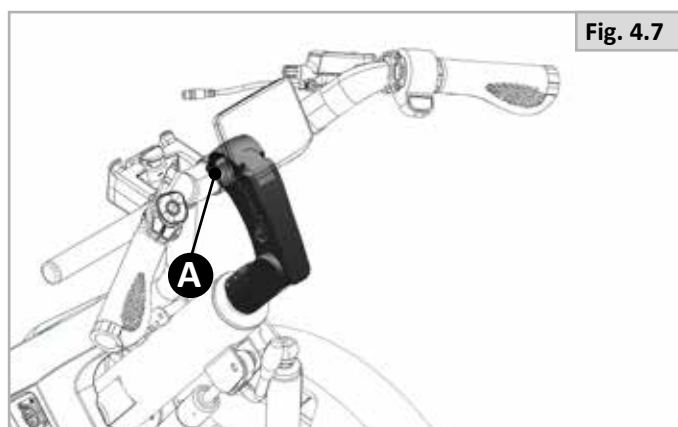
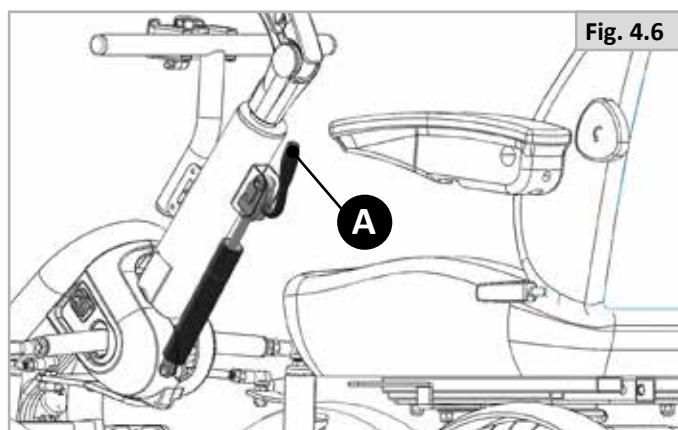

4.8.2 Tyres

Your S800 is installed with Trail tyres with rough tread as standard, and offers good grip on unpaved paths and around the urban environment.

City tyres with a slick tread are available via the Sunrise Medical online spare parts catalogue.

These can be fitted if you will not mainly use your S800 in unpaved paths outdoors and can reduce noise.

4.8.3 Accessory bar (Fig. 4.8)

The front accessory bar can be mounted onto the handlebar stem of the S800. The following accessories can be attached to this bar, with a maximum load capacity of 7 kg:

- KLICKfix Handlebar Adapter
- KLICKfix Lamello Basket 18L
- Mirror (left and/or right)

WARNING!

Watch out that accessories mounted on the accessory bar don't hinder steering or press on the brake lever while steering.

4.8.4 Mounting points for universal mobility scooter accessories (Fig. 4.9)

The S800 is equipped with two mounting tubes on the back of the frame (A) and under the seat (B) as standard. These can be used to mount various universal mobility scooter accessories, such as a canopy, reflective warning triangle (required in Germany), holder for sticks, walker, or oxygen bottle. The maximum load capacity for these mounting points is 10 kg.

WARNING!

- Be aware that attached accessories increase the effective footprint of the scooter.
- Take extra care when manoeuvring if you have a rollator or walker on board.
- Ensure that the load is secured properly before moving off.
- Be aware that the load you are carrying may obscure the rear lights on the scooter. If this is the case, please use the foot path whilst carrying the load, particularly at night.

WARNING!

While you are taking Oxygen, observe all safety regulations pertaining to the use of Oxygen.

- Do not enter an area where naked flames may be used.
- Do not smoke.
- Do not use transmitting devices such as mobile phones etc.

4.8.5 Sunrise Intelligence – Scooter Connectivity (not available for all markets)

If the Sunrise Intelligence - Scooter connectivity module is installed into your S800 Scooter, you can stay connected with the STERLING app, available in the iOS App store or on Google Play store.

The STERLING app for your S800 Scooter, offers a range of benefits for you as a scooter user, please download the STERLING app for further details.

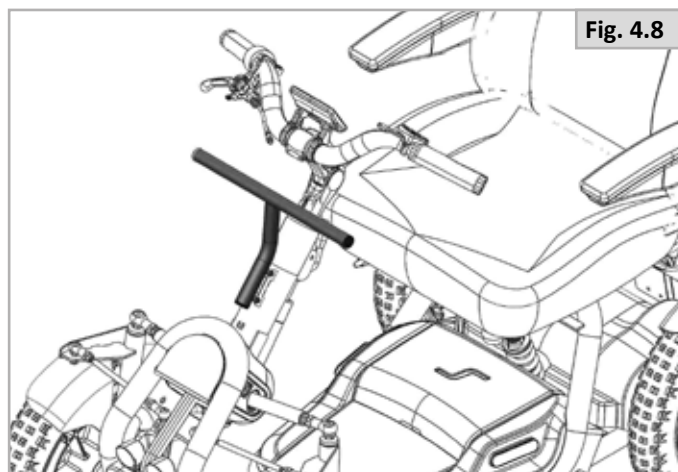

Fig. 4.8

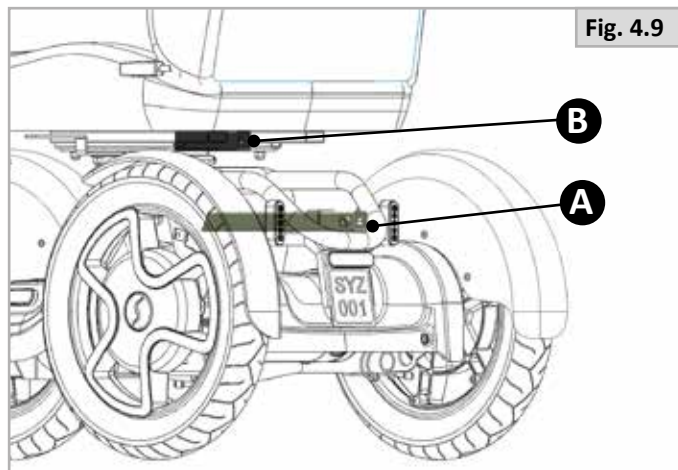

Fig. 4.9

NOTE: If the connectivity module is installed, power consumption in standby mode is higher. Pay close attention to medium to long-term storage, chapter 9.7.



4.8.6 Lap strap / seating positioning belt

⚠ DANGER! / WARNING!

- This product is only to be used to position a single person in a scooter.
- Wear the strap over your clothes.

Mounting a lapstrap / seating positioning belt

Attach the belt straps to the seating frame using a web buckle on the left and on the right. (Fig 4.10)

1. Pass the webbing through the bar buckle. (Fig 4.11)
2. Thread the belt strap around the seating frame. (Fig 4.12)
3. Now pull the strap through the triglide and adjust the desired length. (Fig 4.13)
4. Lastly insert the belt strap back through the triglide. (Fig 4.14)

For your comfort, the Lap Belt must be correctly fitted to the scooter. If you are unsure about the fitting or operation of this option, please contact your approved Sunrise Medical dealer.

Application

1. To open the lock, press the red button and pull the lock apart. When closing, an audible „click“ indicates that the lock has engaged correctly.
2. The length of the belt can be adjusted using the quick adjuster and is secured with a triglide. To adjust, first remove the slack end of the belt from the triglide. Pull the strap vertically away from the lock to shift the belt system. Adjust the lap strap to suit, leaving no more than a hand's width gap for comfort and safety (Fig 4.15). The hand clearance should be with the lap strap under normal tension and not allow large gaps or loops.

⚠ DANGER! / WARNING!

- Always make sure that the lap strap is correctly secured and adjusted prior to use. If a strap is too loose it could cause the user to slip down and cause serious injury.
- Check for correct operation of the release buckle and for any signs of wear on the material or plastic brackets every month. Defective or damaged positioning belts must never be used and must be replaced immediately.
- Belt ends: Loose belt ends can get tangled and get caught in the spoke wheels. Make sure that the strap ends are securely stowed.
- Seat belt buckle: There is a risk of crushing. Always ensure that the belt buckle is properly engaged.

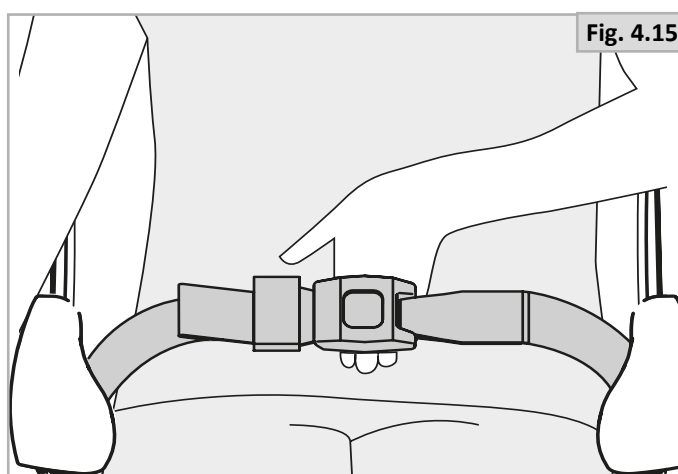
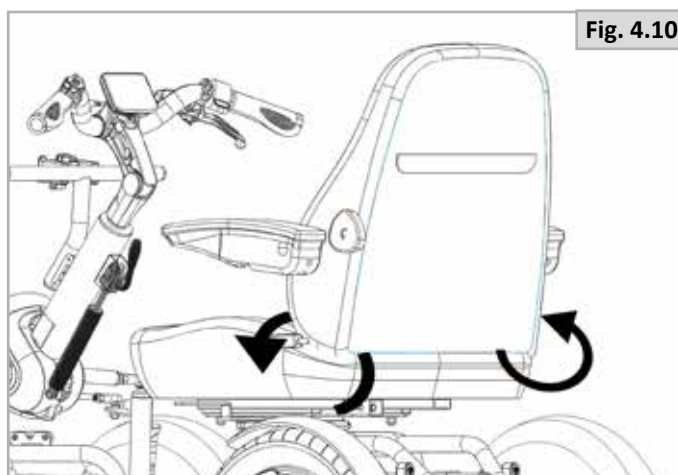

5.0 Using the scooter

DANGER!

- Be aware that you may need to adjust the controller settings of your scooter.

DANGERS!

Weight limits

- The user, plus options and accessories, plus items carried should never exceed the maximum user weight.
- Never sit in the scooter while weight training if the total weight (user plus additional weights) exceeds the maximum user weight.
- Exceeding the weight limit is likely to damage the seat frame or fasteners and may cause severe injury to you or others from scooter failure.
- Exceeding the weight limit will void the warranty
- Do not hang shopping bags from the handlebars as they could swing and cause loss of steering control or cause inadvertent drive actions.
- Do not carry bags or boxes on your lap or footplate, as they may get wedged between the handlebar, or throttle lever, and yourself, or between your feet and the wheels, potentially causing loss of steering control or inadvertent drive actions.
- Do not overload the front and rear baskets as steering control and stability will be negatively affected.

5.1 Checking scooter before use

Perform the following daily check routine before driving:

WARNING!

- Ensure all controls are functioning properly.
- If you discover any scooter malfunction, take it to be repaired or reset. Your dealer can help you find the fault and correct it.
- When traveling along, always ensure the backrest is upright and the seat faces forward.
- Never short-circuit an electrical connection as you could cause an explosion.
- Do not use the scooter if any of the tires are damaged or under/over inflated.
- When using mobile phones, you should switch the scooter off.
- Do no smoke whilst on board the scooter.
- If you take a break from driving but remain seated on the scooter for more than just a moment; switch the scooter off.

CAUTION!

Checking wheels & tyres

- Are the tyres sufficiently inflated (Chapter 9.2).
- Low tyre pressure will reduce your range and make steering more difficult.
- High tyre pressure will result in an uncomfortable ride and increase the risk of a flat tyre.
- Regularly check the tyres for wear and cracks.

Checking batteries

- Before using your vehicle for the very first time, please charge your batteries for a period of 24 hours.
- Are the batteries sufficiently charged? The green lights on the battery charger must be on. (Chapter 7.2).
- Do not use the scooter when the battery charge level is low. The scooter may come to a sudden, unexpected stop.

Checking lights and indicators

- Ensure that the lights and indicators are functioning correctly and lens are clean before going outdoors at night.

Checking throttle

- With the control system switched off, check that the throttle is not bent or damaged and that it returns to the centre when you push and release it.

Checking freewheel lever

- Before using the scooter, ensure that the free wheel lever has been set to 'DISABLE' (Chapter 5.8).

Checking seating

- Ensure that all the cushions are in place.
- Make sure that the backrest is correctly fitted and adjusted.
- Visually inspect the Scooter to make sure the armrests etc. are correctly positioned and all fasteners are sufficiently tightened.

Checking clothing on potential entrapment

- When operating the scooter, ensure that your clothing does not hamper the Scooter (i.e. too long). Before use, always check that your clothing or accessories do not come into contact or become entangled with the wheels and/or other moving and/or rotating parts of the scooter.

Checking weather conditions

- As with many electric vehicles in winter, and very cold temperatures the batteries have a reduced capacity. This can impact the distance you can travel in your S800 scooter. Be mindful of driving in very cold temperatures and the reduction of driving distance versus what may be displayed on the information screen.

WARNING!

Avoid wearing loose cuffs/sleeves when operating the throttle as this could cause entanglement.

5.2 Making a transfer (Fig. 5.1)

DANGER! / WARNING!

To make getting on and off the S800 as easy and safe as possible and to prevent falls, follow these steps:

1. **Power Off:** Ensure the S800 is turned off during transfers to avoid unintentional movement. If left on, accidental contact with the controller may cause the scooter to move unexpectedly.
2. **Adjust Steering Direction:** Turn the wheels to the right if exiting on the left side, and to the left if exiting on the right. This creates additional foot space.
3. **Rotate the Seat:** Push the seat rotation lever (A) forward and turn the seat until it faces you. Ensure the seat is securely locked into position.
4. **Return Seat to Forward Position:** Once seated, push the rotation lever again and turn the seat forward. Make sure it locks with a click, indicating it's safe for use while driving.
5. **Adjust Seat Position:** Use the seat sliding lever to move forward or backward to a comfortable position. Ensure it locks securely.
6. **Foot Placement:** Place your feet firmly in the front foot compartment of the scooter.
7. **Adjust the Tiller:** Adjust the tiller (B) so that all controls are within comfortable reach.

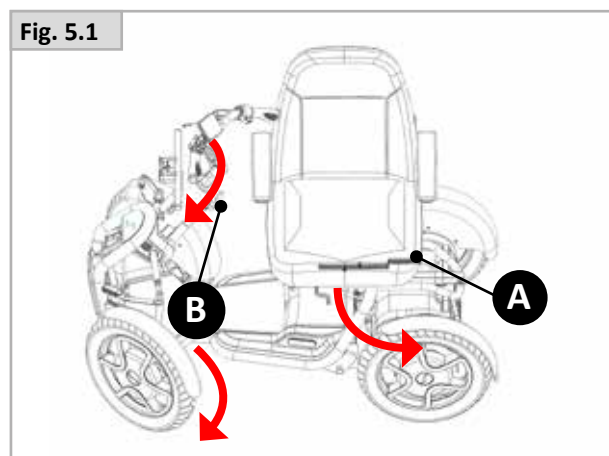

5.3 Driving the scooter

WARNING!

- The user of the scooter is completely responsible for complying with the applicable local safety regulations and guidelines at all times.
- Scooters are driven by means of the operating lever and the control panel (buttons), chapter 6.

Rear view mirror

WARNING!

- To avoid injury to people around you please be aware that the mirror protrudes outside the space envelope of the scooter and could cause injury to someone when driving past.
- The mirror must be used on models at speeds over 6.4 kph (4 mph) on roads according to local law.
- Always make sure that when using the mirror that it is clean and unbroken so that it does not impair your visibility.

Road use

Please show the utmost consideration for the other traffic on the road.

DANGER!

- Remember that the last thing a car or lorry driver expects to see is a scooter backing off the kerb into the road.
- If in any doubt, do not risk crossing the road until you are certain that it is safe.
- Always cross the road as quickly as possible, there may be other traffic.
- Do not drive over anything that could cause punctures in the tyres.
- Ensure that there are no objects in your path that could possibly become lodged in your scooter mechanism or in the spokes of the rear wheels. This could cause the scooter to come to a sudden stop.
- Riding over drains or grids could cause the scooter wheels to become lodged, causing the scooter to come to a sudden stop.
- When using your scooter on public walkways and footpaths, always be aware of pedestrians and situations which might require extra care.
- When manoeuvring in confined areas, including shops, ensure the minimum speed is selected.
- For the safety of the operator and other pedestrians, Sunrise Medical recommends that whilst driving on footpaths and other pedestrian walkways, the scooter preset speed should be set to less than 4 mph/6 kph.

Additional dangers

- Be especially vigilant around young children and pets.
- Remember, when driving in public places drive with caution and regard for others at all times.
- Remember to keep the key with you and/or do not forget the password you set at all times for your safety and security.

Adverse conditions:

Please be aware that when driving your scooter in adverse conditions, e.g. on wet grass, mud, ice, snow or other slippery surfaces, you may experience a reduction in the grip and traction of your scooter.



- We recommend you take extra precautions in these conditions, particularly on hills and slopes; your scooter could become unstable or skid causing possible injury.
- When you are using a Scooter, take extra care with loose or long items of clothing. Moving parts, such as wheels, can be potentially dangerous or even fatal if clothing becomes entangled.

NOTE:

Extreme variances in temperature may trigger the self-protect mechanism in the control system. If this occurs the control system will temporarily shut down to prevent damage to the electronics or the scooter.

5.4 Curves

Steering the scooter is easy and logical. Just be sure to remember to get wide clearance when turning so that the rear wheels clear any obstacle.

Shortcutting a pavement corner can cause the back wheel to go off the pavement, causing problems if the corner is very rough. This can be avoided by steering an exaggerated curve around the obstacle.

When steering in a tight spot, such as a doorway or when turning around, stop the scooter and then turn the handlebar to where you want to go, then apply power gently. This will make the scooter turn tightly. It is also recommended that the pre-set speed is set to a slower setting to aid control in tight spots.



Full speed turns should not be attempted. If you need to turn sharply you must reduce your speed with the throttle or speed setting. This is particularly important when travelling across or down a slope. Disregarding this advice could lead to your scooter tipping over.



Use indicators when changing direction.

5.5 Braking & Emergency Stop

There are three ways to stop your scooter:

- The simplest and safest way to stop the scooter is to release the throttle. This will bring the scooter to a halt in a controlled manner.
- Pressing the stop button on the control panel will brake the scooter abruptly with a fast stop.
- Pulling the handbrake while the scooter is in motion will also bring the scooter to a halt.

In the event of a major system failure, the S800 will activate the mechanical fail-safe brake. This allows the S800 to come to a safe stop in any situation.



- The S800 can brake very powerfully. Under full braking force and poor road surface grip, the wheels of the S800 can lock, reducing the vehicle's control. Always apply the braking force proportionally to the speed, weight, and slope you navigate, whether going up or down.
- Always hold the steering wheel with your hands when braking, so you can always continue to steer.
- Always deactivate the parking brake before you're going to drive.

5.6 Driving on a slope (Fig 5.5)

Your scooter has been designed and tested to allow its use on slopes or gradients of at least 10°.

DANGER!

- Stopping distances on slopes can be significantly longer than on level ground.
- Always drive slowly on steep slopes and pay extra attention. Driving on slopes (forward or backward) is always dangerous.
- The centre of gravity shifts as you drive up or down a slope. Be aware of this. In certain circumstances, your scooter could become unstable.
- To improve stability, lean forward when driving uphill, with the seat and back in an upright position.
- Alternatively, sit in an upright position when travelling in a forward, downhill direction or and/or recline the seat backwards.
- Never use the freewheel on a slope.

If you are in any doubt about the capabilities of your scooter on a slope, then do not attempt to drive up or down the slope/kerb; try to find an alternative route.

Gradients: ascents

WARNING!

- When going uphill, keep the scooter moving. Avoid driving up slopes > 10° for long periods of time. This can cause excessive wear to the engine and electrical parts.
- If you have stopped on a hill, you should start slowly.
- If necessary, lean forward.

Gradients: descents

On descents, it is important not to let the scooter accelerate beyond its normal level of ground speed.

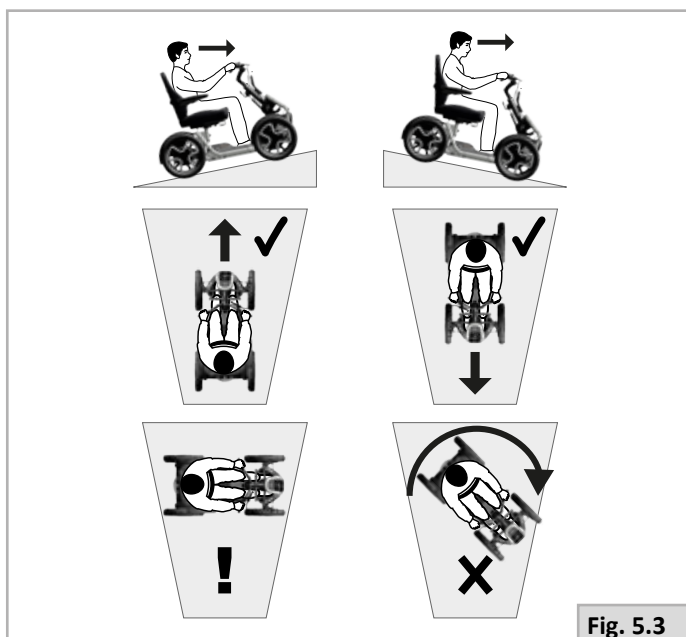

DANGER!

- Proceed slowly down steep descents, (below the speed of 5kph) and stop if you feel anxious.
 - It is safer to proceed slowly down steep descents (below the speed of 3mph, 5kph) and stop, if any anxiety arises regarding the descent.
 - If the scooter picks up speed, release the throttle to stop all forward movement, then restart slowly and do not allow the speed to increase beyond a comfortable level.

5.7 Obstacles & kerbs

DANGER!

- Never descend a kerb backwards.
- Do not attempt to climb or descend a series of steps or use on escalators. It is unsafe to do so and could cause personal injury or damage the scooter. This scooter has only been designed to climb a single step or kerb.

Kerb climbing

Always approach a kerb at 90° (Fig. 5.7).

- Approach the kerb or step, head on at a 90° angle.
- Drive forwards slowly and steadily.
- Carefully accelerate and take a run-up distance of 50 cm. The maximum threshold height you can drive up is 10 cm. It is better to mount the pavement using a curb cut.
- As far as possible, keep the steering wheel in the straight forward position.

Dismounting the kerb

DANGER!

Move the scooter slowly and carefully in a forward direction until the front wheel is on the edge of the kerb, again in a 90° position to the kerb.

Drive as slowly as possible off the kerb with the drive wheels. Do not stop the scooter during descent of the kerb. You will feel more secure if you can lean backwards, but if you can't, don't worry, the scooter is stable. As long as you stay within its limitation, you will be quite safe.

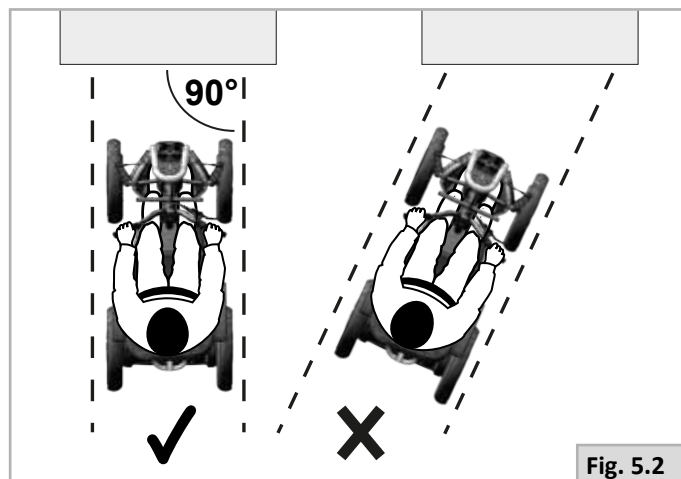

5.8 Pushing the scooter

The scooter can be moved by pushing. To do this, the motors must be disengaged using a freewheel lever. This feature was developed for the attendants of scooter users and also functions as an emergency freewheel lever.

The freewheel lever has 2 positions:

DISABLE (Fig. 5.8, A)

All movement, including braking, is exclusively controlled by the operation of the electronic control system.

ENABLE (Fig. 5.8, B)

Movement is by manual means. Movement can also occur due to gravity, (potholes, kerbs, hills or inclines etc).

DANGER!

- The free wheel lever should only be operated by the attendant and never by the user.
- A user may never be left unattended while the scooter is in 'push' (B - Fig. 5.8).
- Never set the lever to the 'push' position on a slope! When the freewheel lever is set to 'push', the automatic parking brake is deactivated. This makes it possible for the scooter to roll down the slope.
- The automatic parking brake only works is the lever is set to 'drive' position.
- When the scooter is no longer being pushed, the freewheel lever should be set to 'drive' immediately.
- To manually push the scooter, you must release the motor brake.
- Do not engage or disengage the motor brake unless power to the scooter is off.
- Make sure you have full control over the scooter when you release the motor brake. When you do so the scooter will have no braking capability.
- Make sure the scooter is on level ground before you release the motor brake.
- Propel this scooter by the steering wheel and seat back only. They provide secure points for you to hold the rear of the scooter to prevent a fall or tip-over.
- Check to make sure push handle grips will not rotate or slip off.

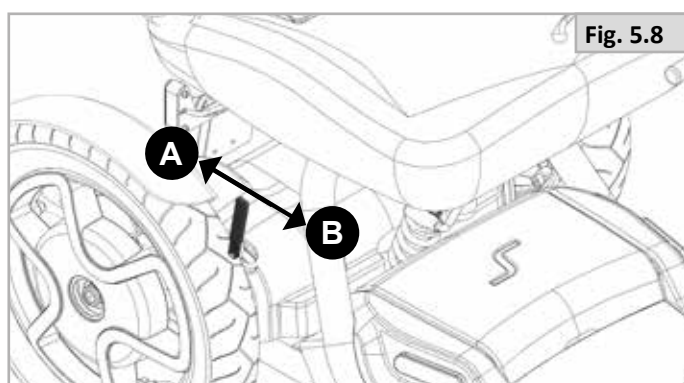

Fig. 5.8

5.9 Using Near Water

Take extra care when using your scooter near open water. Canal tow paths, beaches, quay sides and riverbanks can be hazardous.

DANGER!

- Do not travel along a sloping surface leading to an open water's edge.
- Keep a distance of at least one scooter length from an open waters edge whenever possible.
- Beware of hidden obstacles such as tree roots drain covers and mooring rings as these may cause loss of control if you hit them unexpectedly.
- Use a low speed setting.
- Never reverse towards open water.
- Do not drive up or down steep slopes located near an open water's edge.
- Give way to pedestrians on canal tow paths and footpaths.
- Sound the horn to let other people know you are there.
- Never try to manoeuvre around pedestrians if it takes you too close to the waters edge.
- Avoid deep sand, gravel, mud and wet grassy slopes.
- Take extra care on windy days as loose clothing such as capes or blankets can suddenly fly up and may foul the controls or temporarily block your view.
- Do not get close to open water during a storm.
- When stationary, switch the scooter OFF.
- Observe all local byelaws, rules and regulations.

CAUTION!

- Always clean your scooter thoroughly if it has been exposed to mud, sand, salt or other contaminants.
- Do not use a high-pressure washer, (see section 9.6).

6.0 Controls

Fig. 6.1

- A. Left handle
- B. Button panel
- C. Adjustable stem
- D. Display
- E. Adjustable steering column
- F. Throttle control
- G. Parking Brake System (PBS)
- H. Right-handle

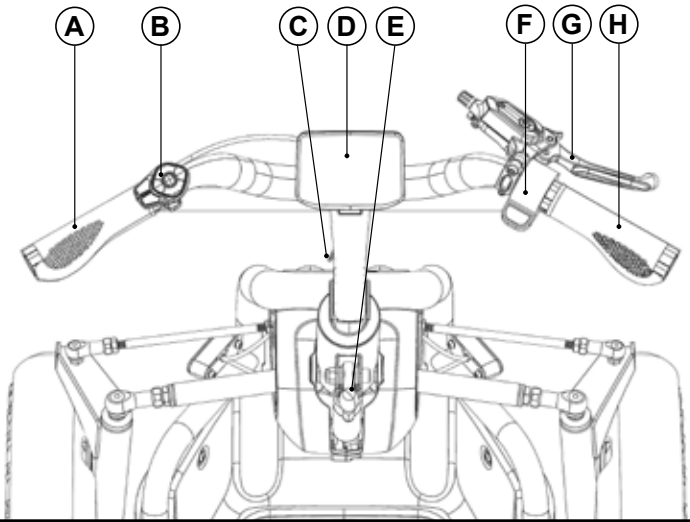

Fig. 6.2

- A. Horn
- B. DR / Cruise Control
- C. Left indicator / Menu
- D. - button
- E. On-Off / Stop
- F. + button
- G. Right indicator / Lighting

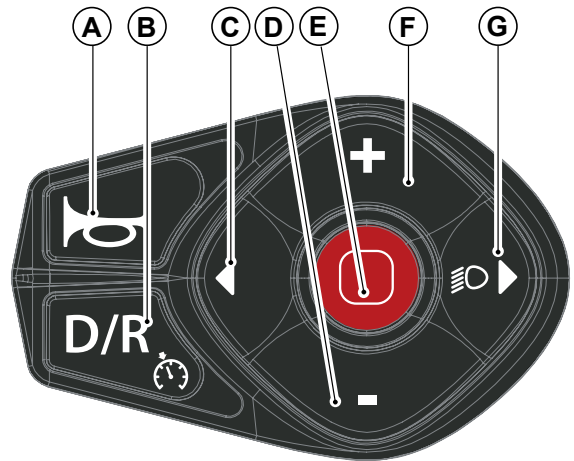
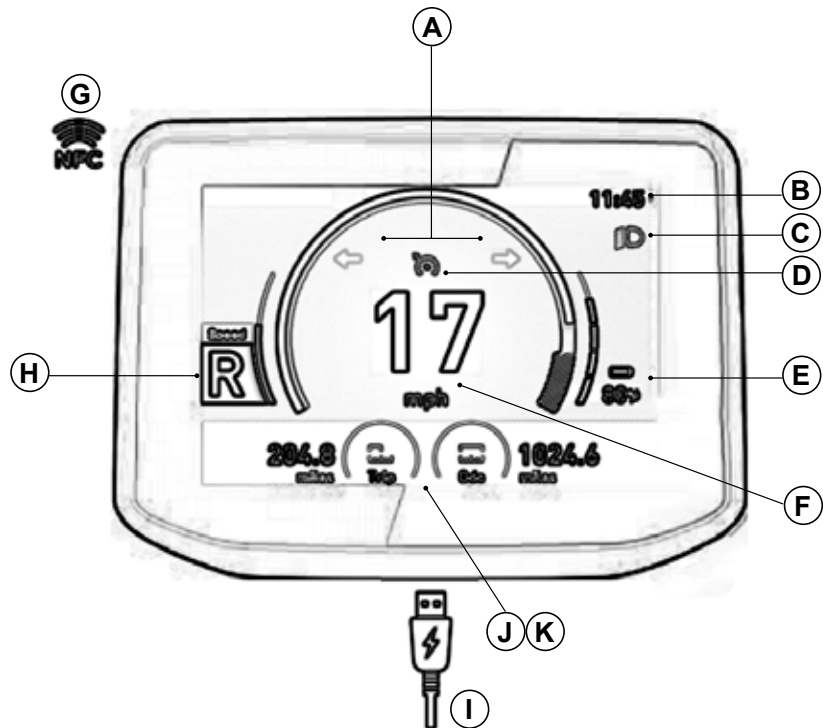

Fig. 6.3

- A. Directional Arrows
- B. Time
- C. Lights
- D. Cruise control
- E. Battery status
- F. Speed
- G. NFC
- H. Speed level
- I. USB port (5V, 500mA)
- J. Trip meter / Odometer
- K. Average speed / Maximum speed
- L. Range

Briefly press the on/off button to switch between J, K, or L.



6.1 Changing Settings

Menu Option	Action	Instructions
Enter Menu	Change settings	<ul style="list-style-type: none"> Press the “left” button for 2 seconds to enter the menu. Use the “+” and “-” buttons to select the setting you want to change.
Display Unit	Change distance unit (Kilometres/ Miles)	<ul style="list-style-type: none"> Press the on/off button to change.
Backlight Brightness	Adjust screen backlight intensity	<ul style="list-style-type: none"> Press the on/off button to change. Adjust with the “+” and “-” buttons. Confirm by pressing the on/off button.
Set Time	Change time settings	<ul style="list-style-type: none"> Press the on/off button to change. Adjust hours with the “+” and “-” buttons. Confirm with the on/off button. Adjust minutes with the “+” and “-” buttons. Confirm with the on/off switch (2B3).
Password	Turn password on/off	<ul style="list-style-type: none"> Press the on/off button to change. Press the on/off button again to select. Press the on/off button to change.
	Set Password	<ul style="list-style-type: none"> Press the on/off button to change. Use the “+” and “-” buttons to select. Confirm choice with the on/off button. Select the desired number with the “+” button and confirm with the on/off switch. Repeat this step for all four numbers.
Manage keys	Key Management	<ul style="list-style-type: none"> Press the on/off button to change. Press the on/off button to change. Select the key you want to remove with the “+” button. Confirm choice with the on/off button. Select ‘confirm’ with the “right” indicator button. Confirm choice with the on/off button.
	Program New Key	<ul style="list-style-type: none"> Press the on/off button to change. Hold the NFC tag against the left upper backside of the display
Clear Trip	Reset the trip meter	<ul style="list-style-type: none"> Press the on/off button to reset. Choose “Yes” or “No” with the “+” and “-” buttons. Confirm with the on/off button. <p>NOTE: This also resets max speed, average speed, and trip time.</p>
System Info	View system information	<ul style="list-style-type: none"> Press the on/off button to view.
Back	Exit the menu	<ul style="list-style-type: none"> Press the on/off button to exit the menu.

6.2 Switch On/Off

6.2.1 Switch on with key

1. Turn the S800 on by pressing and holding the On/Off button for 2 seconds.
2. Wait until the key icon appears on the screen with the text 'scan key here' (Fig. 6.4). This screen appears only if the password is enabled.
3. Hold the NFC key against the back of the display in the top left corner and wait until the key icon disappears.
4. The S800 is in the neutral position. Read more at 6.4.1 driving forward.

6.2.2 Switch on with password

1. Turn the S800 on by pressing and holding the On/Off button for 2 seconds.
2. Wait until the key icon appears on the screen with the text 'scan key here' (Fig. 6.4). This screen appears only if the password is enabled.
3. Press the "left indicator" button.
4. Select the correct number with the "+" button and confirm with the On/Off button. (Fig. 6.5)
5. The S800 is in the neutral position. Read more at 6.4.1 driving forward.

6.2.3 Switch off

You can manually turn off the S800 by pressing and holding the On/Off button for 2 seconds. Additionally, the S800 will automatically power off after 30 minutes of inactivity. This timeout setting can be adjusted by your dealer.

WARNING!

- Do not turn off the scooter while driving unless there is an emergency. (Turning it off may shorten the lifespan of the scooter's drive components.)
- To avoid unexpected or unintentional movement of the scooter and to conserve battery power, it is recommended that the S800 is switched off when stationary or not being used.

6.3 Lights

6.3.1 Headlights, daylights and the rear lights

From speed level 3, the lighting remains on continuously. You can also manually switch the lights on or off if desired:

1. Press the "Lighting" button for 2 seconds to switch on the lighting.
2. Press the "Lighting" button again for 2 seconds to switch off the lighting.

6.3.2 Indicators

1. Press the left- or right indicator button to turn on the indicators.
2. After 10 seconds, the indicators will automatically switch off again, or;
3. Press the same button again to switch off the indicator.

Fig. 6.4

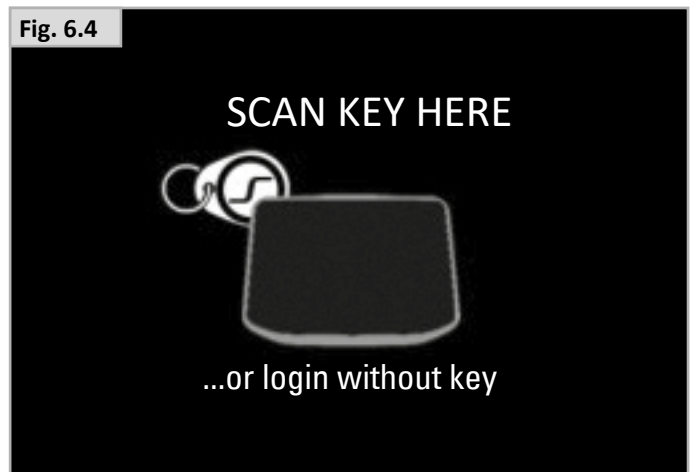

Fig. 6.5



6.3.3 Hazard lights

To activate the hazard lights:

1. Squeeze the brake lever and set it to the lock position. The hazard lights will turn on automatically after 10 seconds.
2. Release the brake lever from the lock position. The hazard lights will turn off.

6.4 Driving

6.4.1 Driving forward

The S800 starts up in the neutral position. First, select the desired driving level before the S800 starts driving.

3. The driving level and the associated maximum speed can be changed by increasing or decreasing the speed level from 1 to 5 with the “+” and “-” buttons. Choose a suitable speed level for each situation.
4. Operate the throttle to move forward. The S800 will gradually accelerate to the set speed.

6.4.2 Reversing

1. Release the operating handle. The scooter will come to a standstill.
2. Press the “D/R” button to engage “Reverse”; the R will appear on the display.
3. Operate the throttle to drive backwards.
4. Press the “D/R” button again to drive forward at the previously selected speed level.



WARNING!

- It is important that you stop the scooter before you change direction from forward to reverse.
- Always turn the scooter control system off before you transfer in or out of the scooter.



DANGER!

- Reversing requires extra attention as the field of vision is restricted.

It is advisable that during the first few sessions of operating your scooter that the area around you is clear of obstacles and pedestrians.

6.4.3 Cruise Control

1. Press the “Cruise Control” button for 2 seconds, and the cruise control logo will appear on the display. The cruise control is now enabled and can be used.
2. Hold the throttle fully pressed for 3 seconds, and the S800 will maintain the maximum speed for your current speed level.
3. Change the speed with the “+” and “-” buttons.
4. Switch off the cruise control by braking or touching the throttle. The Cruise Control is always disabled after braking and must be re-enabled.

6.5 Braking

To stop the Scooter simply release the throttle, while keeping your hands on the handlebar. Two types of braking will automatically operate in sequence:

- Automatic regenerative braking, which slows the Scooter to a standstill.
- Automatic parking brake which will operate as the scooter comes to a stop. The automatic parking brake holds the Scooter in position, even if you are on a hill.

NOTE: This is a two-stage process and is not instantaneous. First the scooter slows down and stops, then the parking brake comes on. When starting off again the parking brake will be released automatically. If the throttle is momentarily engaged and released, the parking brake will release and then engage again in approximately 1/2 a wheel turn.

When stopping the high visibility rear LED braking lights will illuminate. These also function when the scooter lights are turned on.

6.5.1 Emergency Braking Using the Hand Brake

In the unlikely event of an unwanted movement of the Scooter, use the Parking Braking System (PBS) hand brake. The Parking Braking System (PBS) is operated by pulling the hand brake lever on the handlebar, this will slow the scooter to a controlled stop.

The hand brake automatically stops the drive unit by way of an electrical connection. Releasing the hand brake lever will allow the drive unit to function again.

- Activate the parking brake by squeezing the brake and pressing the pin to lock.
- Deactivate the parking brake by squeezing the brake so that the pin clicks out.

NOTE: The scooter will not drive with the handbrake applied. If the scooter is turned on with the handbrake applied, the hazard lights will activate after 10 seconds.

6.5.2 Emergency Braking Using The Stop Button

In the unlikely event of an unwanted movement of the Scooter, pushing the stop button will cause the scooter to come to an immediate stop. Though very effective, emergency braking is extremely abrupt and must never be used in normal use.

7.0 Batteries, charging and range

7.1 Batteries

⚠ CAUTION!

- The S800 uses one of the latest technologies, Li-Ion battery packs. The nominal voltage of this battery is 24V.
- When the batteries are worn out, take them to the local authority disposal point.
- Return the batteries back to Sunrise Medical or directly to the battery manufacturer for recycling, when they no longer hold charge.
- Avoid draining the batteries completely. If one of the battery cells is deeply undervolted, the battery can no longer be charged and will have to be replaced.
- Charge fully drained batteries as soon as possible using a 24-hour cycle.

⚠ DANGER!

- Do not expose any part of the battery to direct heat (i.e. naked flame, gas fire).
- Do not, under any circumstances, tamper with the batteries. If in any doubt, contact your local Sunrise Medical authorised dealer.
- Batteries can be dangerous. Only a certified technician can install and maintain them safely and correctly. Technicians have the necessary qualifications and tools to carry out installation and maintenance safely and correctly.

Safety cut-outs

In the event of a short circuit there are several safety systems built into your scooter to safeguard your electrical circuits, (Fig. 7.1).

1. A resettable fuse of 100A, built into the battery.
2. A 10A glass fuse built into the charging wire.

To replace them contact your Sunrise Medical authorised dealer, who will also diagnose the original fault.

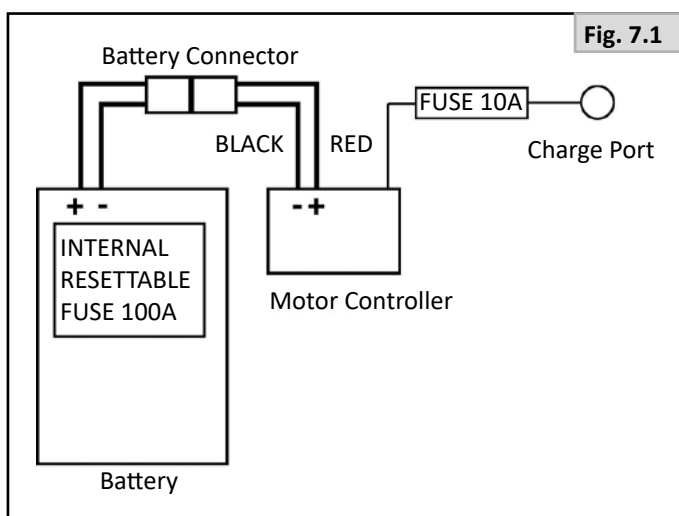

Fig. 7.1

7.2 Charging batteries

📖 Battery charger: Please read the owner's manual with the charger supplied carefully. The general procedures and effects for the interference with the scooter and the batteries remain valid.

Battery care plan

Below is set out a battery care plan for maintenance free batteries. This has been agreed between Sunrise Medical and the battery manufacturers, to enable you to get the best out of your batteries. If a different care plan is followed, this may result in lower-than-expected performance from your mobility vehicle.

- Only use an approved Sunrise Medical charger compatible with the vehicle to be charged.
- Always fully charge the battery before first use.
- Charge your batteries every night, regardless of the amount of use your mobility device has had during the day.
- Charge the batteries in a well-ventilated and dry area.
- If you leave your vehicle for an extended period (more than 15 days), charge the batteries fully.

7.2.1 Charging Socket (Fig. 7.2)

⚠ WARNING!

- The charging socket should only be used for connecting the scooter battery charger plug to the scooter.
- The charging socket should not be used to supply power for any other device.
- Connection of unapproved electrical devices may damage the control system or compromise the EMC performance of the scooter.

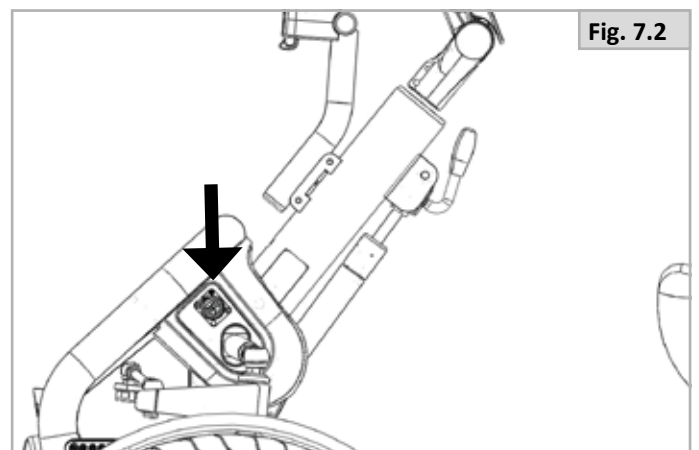

Fig. 7.2

Reading the battery status

The battery-shaped indicator on the display shows the remaining battery capacity in percentage.

Battery status	Colour	Indicator
21-100%	Green	The battery is full.
11-20%	Orange	The battery is almost empty, we recommend charging the battery as soon as possible.
0-10%	Red	The battery is very empty. Charge the battery immediately.

As soon as you start driving, the battery will quickly drop by 10%. This is due to the electrical functioning of the battery and motor. After driving about 1 kilometre, the battery level will stabilise and then decrease by roughly 2% per kilometre. For this reason, we recommend charging the battery when it's around 20% before setting off on a journey.

The display of the S800 also indicates the range in kilometres/miles based on the battery state of charge. This number is only an indication and may change during the ride. Always pay attention to the percentage indication when you should start charging.

Connecting the battery charger

Procedure for connecting the charger and charging

- Connect the battery charger round output plug to the charging socket (see Fig. 7.1).
- Plug the power cord into a wall socket and check whether the charger turns on (blue 'power' light).
- The battery is fully charged when the 'charge' light on the charger lights up green.
- If you want to see exactly how full the battery is while charging, turn the S800 on via the "On/Off" button. The Display will indicate that the S800 is charging and will show the battery status.
- Remove the plug of the battery charger from the wall socket and remove the plug from the charging socket.

For more information about the charger operation, consult the instructions provided with the charger.  BATTERY CHARGER.

Depending on how depleted the batteries are, it may take up to 12 hours to fully charge the batteries again. You can stop charging at any time without negatively affecting the lithium-ion battery.

Country specific information: UK

The 3-pin UK mains input plug contains a replaceable fuse. The rating of this fuse is shown on the charger label.

DANGER!

- Make sure the cord is located so that it will not be stepped on, tripped over or otherwise subjected to damage or stress.
 - Do not rest the battery on top of the charger.
 - Do not stand the charger on a carpet or other soft surface. Always place it on a hard flat surface.
 - Do not operate the charger if it has received a sharp blow, been dropped or otherwise damaged in any way. Take it to a qualified technician.
 - Never sit with the charger on your lap when charging your batteries
 - The charger casing will get hot during its normal operation.
 - Do not disassemble the charger; only have it repaired by the manufacturers. Incorrect re-assembly may result in a risk of electric shock or fire.
 - To reduce the risk of an electric shock, unplug the charger from the outlet before attempting any maintenance or cleaning. Turning off the controls will not reduce the risk.
 - Never smoke or allow a spark or flame in the vicinity of battery or charger.
 - You should not charge your batteries outdoors.
- It is advised to use a smoke detector in the charging area.

7.3 Lithium-ion battery below 3°C

Charging

The lithium-ion battery of the S800 should not be charged if its core temperature is below 0°C, as this can cause damage to the battery. The S800 features regenerative braking, which means the battery is also charged while braking. Additionally, the battery in the S800 has a preheating function. When the battery temperature is below 3°C, and you start charging, the battery will first warm itself up before it begins charging. This preheating process means that charging will take longer than usual. A warning will be visible when the battery heating is active.

Usage

When the battery temperature is below 3°C, and you turn on the S800 (without presenting the key or entering the code), the S800 will automatically activate the battery heating. If you unlock the S800, a warning will appear on the display showing the current battery temperature. Once the battery temperature reaches 10°C or higher through heating, the warning will disappear, and you can use the S800 as normal. A warning will be visible when the battery heating is active.

CAUTION!

You can continue to use the S800 while it is heating, but this comes with an additional risk. If the battery cells are below 1°C, they will be damaged if charged during braking. The S800 brakes regeneratively, which means the battery is charged while braking. You can prevent damaging the battery by:

- Waiting to drive until the core temperature of the battery is above 1°C.
- Driving slowly (speed level 1), braking as little as possible and/or decelerating slowly.
- Avoiding prolonged downhill driving.

CAUTION!

- Keep in mind that the heating consumes power, causing the battery charge to deplete faster than usual.
- When possible, we recommend storing the S800 in a frost-free area.
- The battery's heating and cooling are highly dependent on the conditions. Therefore, it is not possible to predict how long it will take to warm up. An indication is an increase of +5°C per hour.

7.4 The range of your vehicle

Please refer to the specification tables at the back of this manual for Energy Consumption, (Maximum Range), information.

Most manufacturers of mobility products state the range of their vehicles either in the sales literature or within the Owner's Manual. The range stated sometimes differs from manufacturer to manufacturer even though the battery size is the same. Sunrise Medical measures the range of their vehicles in a consistent and uniform manner, but variances still occur due to motor efficiencies and overall product load weight.

The range figures are calculated to I.S.O. Standard 7176. Part 4: Wheelchair Energy Consumption Theoretical Range.

This test is carried out in controlled conditions with new, fully charged batteries, on a level test surface and a user weight of 100 kg. The range figures stated should be seen as a theoretical maximum and could be reduced if any single, or combination, of the following circumstances occur:

- User weight heavier than 100 kg.
- Batteries whose age and condition are less than perfect.
- The terrain is difficult e.g. very hilly, sloping, muddy ground, gravel, grass, snow and ice.
- The vehicle climbs kerbs regularly.
- The ambient temperature is very hot or very cold.
- Incorrect tyre pressures in one or more tyres.
- Lots of start/stop driving.
- Also, thick pile carpets within the home can affect range.
- Use of additional power consumption options (e.g. light, actuators, etc.)

The battery sizes available on each Sunrise Medical product should give sufficient range to cope with the majority of customer's lifestyles.

7.5 Battery warranty

Battery warranties are subject to periods set by the manufacturers. However, most of these warranties are subject to a wear and tear clause, and if you genuinely wear out your batteries in 6 months, it will not be possible to obtain a replacement under warranty.

7.6 Battery Removal

Replacing and servicing batteries is to be done by a qualified specialist.

In case of malfunctioning batteries, contact your local dealer.



Do not attempt to replace or service batteries without the supervision of trained and qualified personnel.



Use proper lifting technique to avoid injury.

1. *Remove the seat*
2. *Push the seat lever (Fig 5.1, A) forward.*
3. *Turn the chair 45 degrees.*
4. *Lift the chair off the base.*
5. Remove the 'Electronics cover' (Fig 3.1, 9)
6. Unplug the red main power connector.
7. Remove the 'Feet compartment' (Fig 3.1, 5), by unscrewing 6 hex screws and 4 bolts.
8. Remove the 'Battery cover' (Fig 3.1, 7)
9. Remove the two M5 bolts securing the Electronics plate to the main frame. These bolts are accessible from the outside of the main frame, on each side of the scooter
10. Unplug the battery CAN bus connector (green, yellow, red cable).
11. Lift the battery from under the Electronics plate and guide the cables carefully.



Move the battery to a safe place.

7.7 Disconnecting batteries for air transport

- Remove the 'Electronics cover' (Fig 3.1, 9)
- Unplug the red main power connector.

8.0 Transport

8.1 Transportation in vehicles

This scooter is not suitable to use as a seat in a vehicle.



Not crash tested



DANGER!

A scooter secured in a vehicle will not provide the equivalent level of safety and security of a vehicle seating system. It is always recommended that the user transfers to the vehicle seating.



WARNING!

Do not sit in your scooter when it is transported (Fig. 8.1).

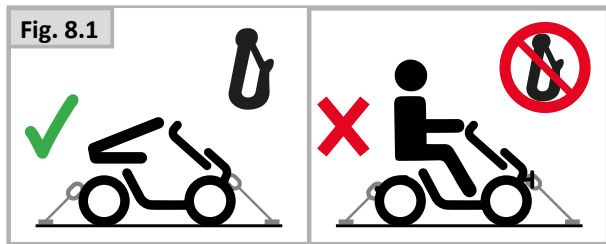

NOTE: The S800 does not comply with the European standard PRM-TSI annex M. Using the S800 on public transport is therefore not guaranteed.

8.2 Using your scooter on the train

If you wish to use your scooter on the train, we recommend that you contact the train operator in advance when planning your journey. Railway carriages have provision for a “wheelchair” space where you can sit on your scooter during the journey. Please note that the overall length of your scooter may be greater than the available length of the “wheelchair” space in the railway carriage.

When planning your journey, you should check with the train operator that there will be suitable boarding access available to allow you to access the railway carriage and the intended “wheelchair” space on joining and leaving the train and there is suitable access onto the platform. We recommend you check with the train operator that; the boarding access is suitable for the combined mass of your scooter and the occupant; the slope of the access is not greater than the maximum safe slope of the scooter; any steps or risers are no greater than the maximum height of the scooter obstacle climbing height; there is adequate turning space within the access area to the train and on the train.

Most train operators will provide assistance provided that arrangements have been made in advance. We suggest you have your Owner’s Manual ready when planning your journey and contacted them.

8.3 Other Transport requirements

The scooter may be transported by road, rail, sea or air as luggage.

Before you travel, please contact the appropriate carrier or travel operator. You may be asked to provide certain information about the scooter such as the scooter mass and overall dimensions. This information can be found in the relevant model tables in section 12.0.

If the scooter is transported by air, the batteries may need to be removed as the batteries supplied may not be IATA approved for air travel.

If transporting the scooter by road as luggage, it may need to be secured to prevent unintended movement into other vehicle passengers in the event of a sudden stop or placed in a space reserved for luggage.

Your scooter can be secured to the mounting points at the rear (Fig. 8.2) and at the main frame at the front (Fig. 8.3).

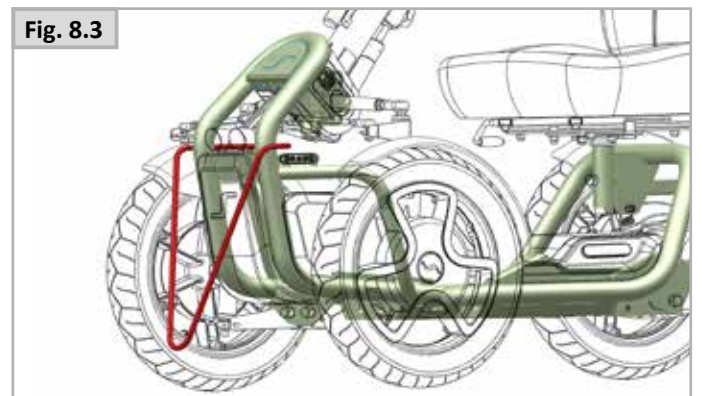
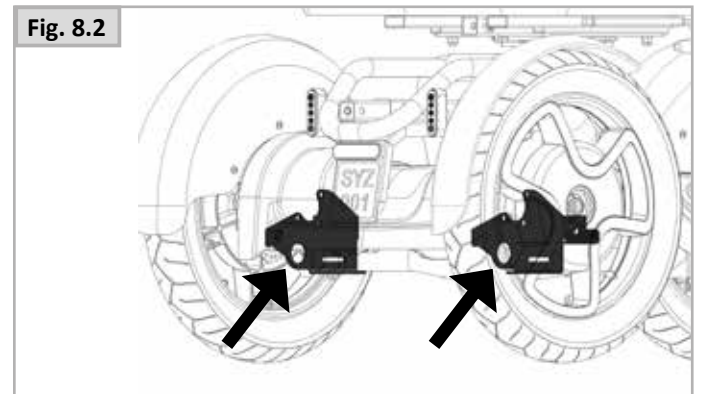

8.4 Making your scooter compact

You can compact the scooter for transport or storage.

Folding the backrest

- Pull up the left armrest.
- Firmly grip the backrest.
- Pull the lever on the left-hand side at the back of the seat up.
- Fold the backrest forward as flat as possible against the seat and release the lever.

Folding the steering column

- Stand next to the S800.
- Pull the steering column adjustment lever down/towards you.
- Move the steering column as far as possible towards the seat and release the lever.

Removable parts without using tools are the basket, headrest and seat.

Removing the seat

- Push the seat lever forward.
- Turn the chair 45 degrees.
- Lift the chair off the base.

9.0 Maintenance & cleaning

The scooter's lifespan is dependent on it being well maintained.

For information concerning specific settings, maintenance or repair work, please contact your authorized Sunrise dealer. Always be sure to mention the model, year of manufacture and identification number provided on the identification plate of the scooter when contacting your dealer.

CAUTION!

The scooter should be serviced by your authorized Sunrise dealer once a year or, in the case of intensive use, every six months. For a list of approved authorised dealers in your area please contact Sunrise Medical Service Centre. The contact details of your local Sunrise medical service centre can be found on the inside front cover of this booklet. National and International Website addresses are on the back cover.

9.1 Maintenance

WARNING!

- Loose fasteners should be re-tightened according to the installation instructions. Please refer (unless otherwise specified) to the general table below for needed Torques.

Torque Setting Guide	
M4	3.0 Nm
M5	5.9 Nm
M6	10 Nm
M8	25 Nm
M10	48 Nm
M12	84 Nm

Note: it will be necessary to use a torque wrench.

- If a broken or loose component is found, discontinue use immediately and contact your authorised Sunrise Medical supplier for replacement.

WARNING!

- If you are in any doubt about the performance requirements of your scooter, contact your Sunrise Medical authorised dealer.
- After performing any maintenance or repairs on the scooter you must make sure that it is functioning correctly before it is used.
- When replacing self-locking nuts, or nuts/studs secured with a thread locking solution, ensure that a suitable thread locking solution is reapplied to the fastener.

Daily checks

Perform the daily check routine before driving as described in chapter 5.1

Weekly checks

Perform the weekly check routine before driving as described below.

Checking Parking brake

This test should be carried out on a level floor with at least one metre clearance all around the scooter.

- Switch on the control system.
- Set the speed level to 1.
- Gradually push the throttle until you hear the parking brake engage.
- The scooter may start to move.
- Immediately release the throttle. You must be able to hear the parking brake operate (click), within a few seconds.
- Repeat the test a further 3 times, gradually pushing the throttle.

Check Brake Lever Connection

- Check the function of the brake lever connection by squeezing the brake lever and confirming that the brake lights turn on. This helps prevent the risk of an undetected sensor malfunction and ensures safe operation.

Checking connectors & cables

- Check all cables are not loose and secured to the scooter.
- Check the condition of all cables and connectors for damage.

Checking controller

- Make sure that all components of the throttle are securely mounted.

Checking controls

- Switch on the scooter – Do you see a warning on the screen? This signifies that there is a fault in the electronic system. Refer to chapter 10 for basic troubleshooting.
- Operate all of the electrical options, including lights and indicators, to make sure that they work correctly.
- Drive the scooter in each of the drive profiles to make sure the scooter performs as it did before.

Monthly checks

Perform the monthly check routine before driving as described below.

- All fasteners should be checked monthly for wear, such as loose bolts or broken components.

9.2 Tyre maintenance and pressures

9.2.1 Tyre pressure

CAUTION!

If pneumatic tyres are fitted to your scooter, it is important to regularly check the air pressure and for signs of wear. The maximum tyre pressures are listed in Section 12.0, if in doubt check the markings on the side of the scooter tyre for guidance.

NOTE: It is important that drive wheels are inflated to equal pressures as a pair, and likewise the rear. The inflator pump provides the safest method of inflating your scooter tyres and the pressure can be checked with a standard motor vehicle pressure gauge.

DANGER!

- Do not inflate beyond the maximum allowed tyre pressure.
- Never use a forecourt pump.
- Before tyres are repaired, they must first be fully deflated.

9.2.2 Tyre wear

When inspecting the tyres for signs of wear, look for significant scuffmarks, cuts and a diminished tyre tread. Tyres will need to be changed when the tread cannot be seen over the complete surface of the tyre.

9.3 Tyre Replacement Instructions

WARNING!

- It is not usually practical to try to repair a puncture at the site of the occurrence. Sunrise Medical suggests that you call for help to remove the scooter either directly to an approved service agent, or to a safe place for collection by the approved agent at a later time.
- If you are in any doubt about the servicing requirements of your scooter, contact your Sunrise Medical authorised dealer.
- Do not attempt any task you are not sure of.
- The scooter must be in freewheel 'disable' mode with the power switched OFF, before jacking any wheel off the ground.
- Do not raise more than one wheel of the ground at any one time.
- Do not use high-pressure air delivery systems such as those found on garage forecourts, to inflate the scooter tyres.
- Always use a new inner tube.

Changing the inner tube

- Elevate the wheel by placing a jack under the scooter.
- When elevated back up the jack with solid blocks to increase stability.
- Remove the wheel cap with the logo.
- Loosen the M10 nut.
- Remove the wheel.
- Completely deflate the tyre.
- Remove the 6 M8 bolts holding the inner ring.
- Take the tyre off the rim.
- Place a new tyre and reassemble everything in reverse order.



9.4 Maintenance and Inspection Schedule

Maintenance and Inspection Schedule	Daily	Weekly	Quarterly	Six month	Annually
Check battery level indicator and charge if necessary.	●				
Check the control levers on the handlebar are not bent or damaged.	●				
Ensure all removable parts are securely fastened.	●				
Check lap strap for wear and make sure the buckle is operational.	●				
Check the Parking brake clicks on and off.		●			
Check tyres and inflate if required.		●			
Ensure any visible nuts and bolts are tight.		●			
Ensure all cables and connectors are sound, tidy and out of the way.		●			
Clean the scooter and upholstery regularly.		●			
Battery terminal inspection – Remove any corrosion and apply Vaseline.			●		
Check upholstery, seating, headrests, arm pads for wear.				●	
Complete inspection, safety checks and service should be made by a Sunrise Medical authorised dealer.					●

NOTE: Please refer to the S800 service manual for further details on preventative maintenance.

9.5 Lighting maintenance

DANGER!

Maintaining lights and indicators is a safety critical task. If your lights and indicator system shows a defect, please contact your Sunrise Medical Approved Dealer.

All lights and indicators are state of the art LED low energy, no maintenance units. There are no light bulbs used. The high intrinsic reliability of these units means that they are extremely unlikely to fail under normal usage. If a failure should occur, (maybe because of an impact), the damaged light assembly must be replaced in its entirety. The individual LEDs cannot be replaced.

CAUTION!

- Only use Sunrise Medical authorized spare parts.
- Be advised that all lighting circuits are electronically protected. In the event of a short-circuit current will be limited to a safe level. Once the fault is removed the control system resets automatically.

9.6 Cleaning and disinfection

The scooter should be wiped over once per week with a slightly damp, not wet, cloth and any fluff or dust that has accumulated around the motors should be blown or dusted away.

CAUTION!

Make sure that you dry all parts of your scooter if it becomes wet or damp after cleaning or if it is used in a wet or damp atmosphere.

DANGER!

It is important that should the scooter be used by more than one person it is cleaned thoroughly to ensure there is no cross infection.

Hygiene measures when being re-used:

Prior to the wheelchair being re-used, it must be carefully prepared. All surfaces which come into contact with the user must be treated with a disinfection spray.

To do this, you must use a disinfectant as authorised/recommended in your country, for rapid alcohol-based disinfection for medical products and medical devices, which must be disinfected quickly.

Please take into account the manufacturer's instructions for the disinfectant you are using.

In general, a complete disinfection cannot be guaranteed on seams. We therefore recommend that you dispose of seat and back slings to avoid microbacterial contamination with active agents according to your local infection protection law.

CAUTION!

- Do not use solvents, bleaches, abrasives, synthetic detergents, wax polishes or aerosols.
- Disinfectants may be used in dilution as specified by their manufacturer.
- Ensure surfaces are rinsed with clean water and dried thoroughly.
- Do not use a hose or a pressure or steam washer to clean your scooter.

WARNING!

- Always read the label on any commercial or domestic cleaning substances.
- Always follow the instructions carefully.

Cleaning controls: & Controller

Should the control of your scooter become soiled or dirty, it can be wiped with a damp cloth with a dilute disinfectant until clean.

9.7 Medium to long term storage

When storing your scooter for long periods of time (in excess of one week), follow these simple instructions:

- Fully charge the scooter for at least 24 hours.
- Disconnect the charger.
- The battery's computer continues to use energy, even though this consumption is very low. We recommend charging the battery every three months to prevent it from discharging too deeply.
- Charge the batteries fully before using the S800 again.

WARNING!

Never store your scooter:

- Near a source of direct heat.
- In direct sunlight, as continued exposure to UV rays may weaken plastic and foam parts, i.e. panels, hand grips, etc. and fade labels.
- In a damp environment.
- In a cold environment.

Avoiding all of the above will minimise battery deep cycle discharge and extend battery lifetime.

CAUTION!

- Always switch off and lock the S800 to prevent misuse or theft. For storage, secure a chain lock through a wheel and, if possible, attach the S800 to a fixed object for added safety.
- Always pay attention to what you attach the S800 to so as not to cause a nuisance to others.

NOTE: For additional theft protection, the KLICKfix FindMe holder with AirTag can be mounted in the screw holes under the electronics cover.

9.8 Storage temperature & humidity

Storage Temperature: Min: -25°C, (-40°C without batteries)
Max: 65°C.

Relative Humidity (non-condensing): Min: 5% Max: 95%.

CAUTION!

- Always store the S800 in a dry, clean place, preferably in a garage or shed.
- If you store the S800 in a semi-open space such as a carport, we recommend using a (universal) cover to protect the S800 against the elements.
- Avoid storing batteries at extremely high or extremely low temperatures. The ideal storage temperature is between +15° and +25° Celsius.

10.0 Trouble shooting

If the scooter is not working as it should, check the following points.

- Check whether the batteries are charged by connecting the charger.
- Check whether the batteries are charged.
- Turn the scooter off and then back on again.
- Check whether the battery plugs are all securely in place.
- Check whether the freewheel lever is in the 'DISABLE' position.
- Check the position of the speed regulator.

10.1 Fault codes and possible causes

A fault can be indicated by an error message on the display. Refer to the table below for error codes, their meanings, and solutions. If the suggested solution does not help, always contact your dealer to resolve the error. Provide the error message to the dealer.

Code	Description	Meaning and solution
E01	Low Battery	The batteries are empty. Charge the batteries.
E02	Bad Motor Connection	There is a fault in the motor or its associated wiring. Contact your dealer.
E03	Motor Short Circuit	There is a fault in the motor or its associated wiring. Contact your dealer.
E04	Current Limit Timeout / Controller too hot	The motor is too hot. Turn the S800 off, wait a few minutes, and turn it back on.
E06	Drive Inhibit	There is a blockage preventing the S800 from driving. Ensure the charger is disconnected.
E07	Throttle Fault	The throttle is not in the neutral position when the S800 is turned on.
E08	Controller Fault	There is a fault in the controller or associated wiring. Turn the S800 off, wait 10 seconds and turn it back on.
E09	Park Brake Fault	A switch for releasing the parking brake is active.
E10	High Battery Voltage	If you are driving downhill, the batteries may be overcharging. Reduce your speed to minimise regenerative charging.
E11	Batt. cold	Battery Cold (Read chapter 7.3)
E12	Batt. heating	Battery Heating (Read chapter 7.3)
E13	Batt. < -10°C	Battery temperature < -10°C (Read chapter 7.3)
E14	Batt. < -5°C	Battery temperature < -5°C (Read chapter 7.3)
E15	Batt. < -2°C	Battery temperature < -2°C (Read chapter 7.3)
E16	Batt. < 0°C	Battery temperature < 0°C (Read chapter 7.3)
E17	Batt. < 2°C	Battery temperature < 2°C (Read chapter 7.3)
E18	Batt. < 5°C	Battery temperature < 5°C (Read chapter 7.3)
E19	Batt. < 10°C	Battery temperature < 10°C (Read chapter 7.3)
E20	Batt comm	Communication issue with the battery
E21	WH-Horn-RVS fault	Horn and/or reverse line fault
E22	WH-Brake fault	Brake line fault
E23	WH-FrontLight fault	Front light and daylight fault
E24	WH-Blink fault	Indicator lights fault
E25	WH-Throttle fault	Throttle signal error
E26	Speed-sensor fault	The speed sensor is not working
E27-E67	Empty	Contact your dealer.
E70	Display has lost communication	Communication issue with the display. Restart the S800 by switching it off and on again.

11.0 Disposal

The symbols below mean that in accordance with local laws and regulations your product should be disposed of separately from household waste. When this product reaches the end of its life, take it to the local collection point designated by local authorities. The separate collection and recycling of your product at the time of disposal will help conserve natural resources and ensure that it is recycled in a manner that protects the environment.

Ensure you are the legal owner of the product prior to arranging for the product disposal in accordance with the above recommendations and national requirements.



In the following section, there is a description of the materials used on the scooter, in view of the disposal or recycling of the scooter and its packaging.

There may also be special local regulations in force with regard to disposal or recycling, these must be taken into account when disposing of your scooter. (This can include the cleaning or decontamination of the scooter prior to disposal).

Aluminium: Wheels, motor/gearbox

Steel: Fixing points, frame, seat, seat frame

Plastic: Handles, tube stoppers, shrouds

Packaging: Plastic bags made of soft polyethylene, cardboard

Rubber: Tyres

Disposal or recycling should be done through a licensed agent or authorised place of disposal. Alternatively, your scooter may be returned to your dealer for disposal.

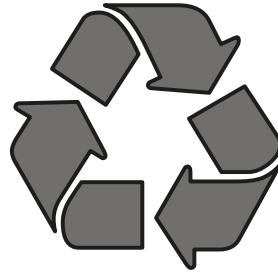

12.0 Specification Sheets (EN 12184 & ISO 7176-15)



This product complies with the regulations and guidelines for medical aids and carries a CE symbol.
 The product meets the requirements and standards below. These are checked by independent institutions.
 EN ISO 10993-5:2009
 Biological evaluation of medical devices - Part 5: Tests for in vitro cytotoxicity (ISO 10993-5:2009)

Standard	Definition / description	Test Dummy Weight	
Medical Device Regulation (EU) 2017/745	Applicable as mentioned in Appendix 1		
EN 12184: 2022	Electrically powered wheelchairs, scooters and their chargers - Requirements and test methods	-	-
Class C	S800	161 kg	
ISO 7176-8: 2014	Requirements and test methods for impact, static and fatigue strengths	N/A	N/A
ISO 7176-9: 2009	Climate tests for electric wheelchairs	N/A	N/A
ISO 7176-14: 2008	Requirements and test methods for control systems for electric wheelchairs	N/A	N/A
ISO 7176-21: 2009	Requirements and test methods for electromagnetic compatibility of electrically powered wheelchairs and motorised scooters	N/A	N/A
EN 1021-2: 2014	Requirements for resistance to ignition.	N/A	N/A

Model	Sterling S800 by Scoozy		
Max. user weight ¹	161kg	354.9lb	
EN12184 class:	C	-	

Description	Metric system values		Imperial system values & alternative		Comments
	MIN.	MAX.	MIN.	MAX.	
ISO 7176-15					
Total length	1370mm		53.9"		
Total width	680mm		26.8"		
Total height	1080mm (<1000mm folded)	1305mm	42.5"	51.4"	without headrest, lowest seat position / with headrest, highest seat position
Total weight	100kg		220.5lb		standard configuration with batteries
Transport weight of the heaviest part: Seat with slide	18kg		-		
Dynamic stability (rated slope)	10°		-		
Min. braking distance at maximum speed	6600mm		-		
Static stability	15°/15°/15°		-		Downwards / Upwards / Sideways
Range of action (ISO 7176-15)	50km		-		NB: The following aspects have a negative influence on the range of action: Obstacles, rugged terrain, driving on slopes, exposure to temperatures below freezing point and frequent use of powered seat options.
Climbing capability for obstacles	100mm		3.9"		
Max speed forward	12.8km/h ²		8mph ¹		
Turning radius	1400mm		55.1"		
Turning space / reversing width	2200mm		86.6"		
Ground clearance	100mm		3.9"		
Wheel size	16 x 3.0"		76/305		
Tyre Pressure	2.5 bar	3 bar	36 PSI	43.5 PSI	For weights up to 80 kg / For weights between 80 and 161 kg
Motor Power	1400 W				
Battery capacity	70 Ah		-		
Maximum permissible charging voltage	-	28 V	-	-	
Maximum charging current	-	8 A	-	-	
Seat angle	3°		-		
Effective seat depth	430 mm		16.9"		
Effective seat width	508 mm		20"		
Seat to floor height	380 mm	420 mm	15"	16.5"	to scooter floor
Back rest angle	-30°	+25°	-	-	
Back rest height	500 mm		19.7"		
Seat adjustment	-68 mm	+68 mm	-2.7"	+2.7"	Front - rear, from centre position
Armrest height	66 mm	360 mm	2.6"	14.2"	To seat surface
Armrest length	330 mm		13"		To backrest

1. The user, plus options and accessories, plus items carried should never exceed the maximum user weight.

2. The speed of the S800 depends on battery voltage and other conditions, and may therefore vary. In certain countries where different rules apply, the maximum speed is limited.

13.0 Warranty

THIS GUARANTEE DOES NOT AFFECT YOUR LEGAL RIGHTS IN ANY WAY.

Sunrise Medical* provides a guarantee, as set out in the warranty conditions, for products to its customers covering the following.

Warranty conditions:









1. Should a part or parts of the product require repair or replacement as a result of a manufacturing and/or material fault within 24 months, then the affected part or parts will be repaired or replaced free of charge. The warranty will only cover manufacturing defects.
2. To enforce the warranty, please contact the supplier of your scooter – e.g. the Sunrise Medical Approved dealership or Healthcare provider with the exact details of the nature of the difficulty. Should you be using the product outside the area covered by the Sunrise Medical customer service agent, repairs or replacement will be carried out by another agency as designated by the manufacturer. The product must be repaired by a Sunrise Medical designated Customer Service agent(, dealer).
3. For parts, which have been repaired or exchanged within the scope of this warranty, we provide a warranty in accordance with these warranty conditions for the remaining warranty period for the product in accordance with point 1.
4. For original spare parts which have been fitted at the customer's expense, these will have a 12 months guarantee(, following the fitting), in accordance with these warranty conditions.
5. Claims from this warranty shall not arise, if a repair or replacement of a product or a part is required for the following reasons:
 - a. Normal wear and tear, which include but is not limited to the following parts where fitted; batteries, armrest pads, upholstery, tyres, brakes shoes, ferrules, etc.
 - b. Any overloading of the product, please check the EC label for maximum user weight.
 - c. The product or part has not been maintained or serviced in accordance with the manufacturer's recommendations as shown in the user instructions and/or the service instructions.
 - d. Accessories have been used which are not specified as original accessories.
 - e. The product or part having been damaged by neglect, accident or improper use.
 - f. Changes/modifications have been made to the product or parts, which deviate from the manufacturer's specifications.
 - g. Repairs have been carried out, before our Customer Service has been informed of the circumstances.
6. This guarantee is subject to the law of the country in which the product was purchased from Sunrise Medical"
7. Life expectancy
We estimate a life expectancy of six years for this product, provided that:
 - It is used in strict accordance with the intended use as set out in this document.
 - All maintenance and service requirements are met.The estimated life expectancy can be exceeded if the product is carefully used and properly maintained, provided that technical and scientific advances do not result in technical limitations.
The life expectancy can also be considerably reduced by extreme or incorrect usage.
The fact that we estimate a life expectancy for this product does not constitute an additional warranty..







* Means the Sunrise Medical facility from which the product was purchased.

Additional Notes For Australia Only:

- i. For goods provided by Sunrise medical Pty Ltd in Australia, our goods come with a guarantee by Sunrise Medical that cannot be excluded under Australian Consumer Law.
- ii. You are entitled to a replacement or refund for a major failure and for compensation for any foreseeable loss or damage.
- iii. You are also entitled to have the goods repaired or replaced if the goods fail to be of acceptable quality and the failure does not amount to a major failure.
- iv. The benefits to you given by this warranty are in addition to your other rights and remedies under a law in relation to the goods to which the warranty relates.

14.0 Name Plate

TYPE	Scooter - For outdoor use		Rear axle - Front axle
NAME	Sterling S800		200 kg - 70 kg
	YYYY-MM	UK RP	MedPath Limited
	10° rated slope		27 Old Gloucester Street
	161 kg - max. user weight		London WC1N 3AX, UK
UDI	(01) 8720648771026	SN	001-01-01
			
	Scoozy B.V. Groothandelsweg 1 2645 EH Delfgauw, NL	CE	UK CA
		MD	

TYPE:	Product Name/SKU Number.
	Maximum safe slope, Depends on scooter setting, posture and physical capabilities of the user.
	Maximum user weight
	Maximum axle loading
UK CA	UKCA Mark
CE	CE Mark
	Indicates electrical / electronic equipment must be disposed of in accordance with the WEEE regulation.
	XXXX-XX-XX Date of manufacture
SN	Serial number
MD	This symbol means Medical Device
	Manufacturer's address
UK RP	UK Responsible Person
CH REP	Swiss Representative's address



ISO 7010-M002
Instruction manual/booklet
must be read! (Blue Icon)

rehabhire & sales

1 300 000 030

320 Lorimer Street Port Melbourne
contact@rehabhire.com.au
rehabhire.com.au

rehabhire & sales **REPAIRS AND SERVICE**

REGULAR MAINTENANCE OR REPAIRS

1 300 000 030

Unit 6 | 52 Wirraway Drive Port Melbourne
service@rehabhire.com.au
rehabhire.com.au/repairs-and-service

rehabinstallation

CAN MODIFY EVERY ROOM IN YOUR HOME TO
ENSURE IT IS ACCESSIBLE, SAFE, AND COMFORTABLE

1 300 000 030

320 Lorimer Street Port Melbourne
contact@rehabinstallation.com.au
rehabinstallation.com.au



Registered NDIS Provider